

X320



**rinstrum**  
SMART WEIGHING SOLUTIONS



## X320 High-impact Washdown Indicator

- Tough enclosure
- IP68 and IP69K rated housing full wash-down
- 20mm (0.8in) LCD display with LED backlight
- Trade Approved Australia/Europe/USA
- AC, DC and rechargeable NiMH battery options
- Built-in RS232 communications port
- Programmable function key
- All in one bracket for wall, desk and pole mounting
- Built-in check weigh function

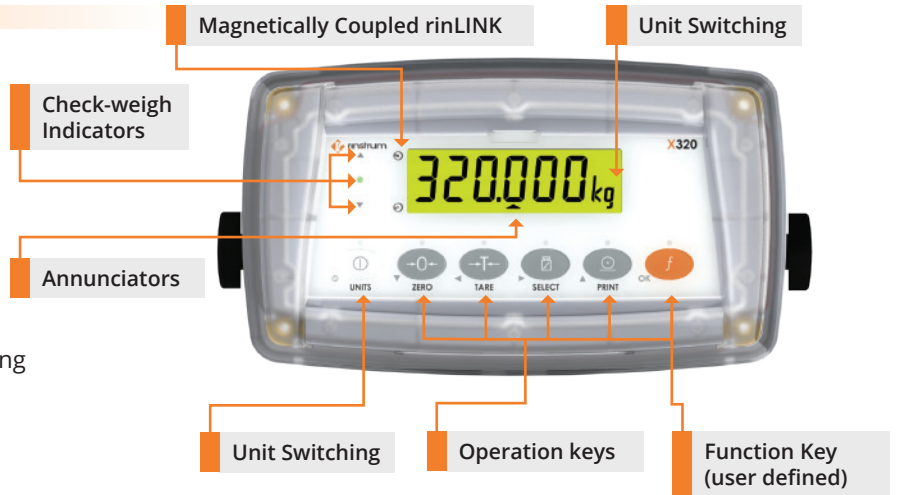

### Exceptional Housing Construction – Sealed and Tough

- Double O-ring to seal the outer housing
- Single piece front panel to protect the display and avoid leaks
- Capacitive keys with no moving parts
- No glued membrane to fail
- No traditional keypad to damage
- No external parts using adhesive
- Sturdy design with enhanced wall strength

### Constructed of a High Tech Plastic Alloy

- Food grade
- Chemical resistant
- Temperature and UV resistant
- Impact resistant – Drop test, Hammer



The use of a capacitive keyboard allows the front panel to be constructed as a single piece. The X320 keypad senses an operator's finger, whether gloved or not, from the inside of the enclosure. There are no moving parts to wear out, no glue to deteriorate and no keypad tails to fail due to vibration or corrosion. The strength of the single front fascia increases the durability of the instrument, protecting the LCD and electronics from external impacts.

## An IP68 & IP69K approved housing

IP68 PASS REQUIREMENTS	IP69K PASS REQUIREMENTS
<b>First Digit IP<sub>6</sub> Test:</b>	
8 Hours in a dust chamber with a vacuum hose attached to the housing to try and draw dust into the unit	
<b>Second digit IP<sub>8</sub> Test:</b>	
1 hour of submersion under 2 metres of water no ingress of moisture	<b>Second digit IP<sub>9K</sub> Test:</b>
	Unit is protected against ingress/damage during high pressure steam cleaning. Hot water sprayed against the housing from every direction at very high pressure must not cause damage (only applies to din 40050 part 9 testing)



2 kPa Vacuum - 8 hrs



10,000 kPa - 80 °C

## View300 for fast simple Indicator setup via a PC

View300 is PC software that displays the complete menu structure of the indicator with convenient drop down menus for setting selection. Use View 300 to:

- Enter custom print strings using the PC
- Setup the indicator and save the configuration and calibration for maintenance purposes or load the RIS file onto multiple indicators
- Create a real time graph from the log that is ideal for diagnostics

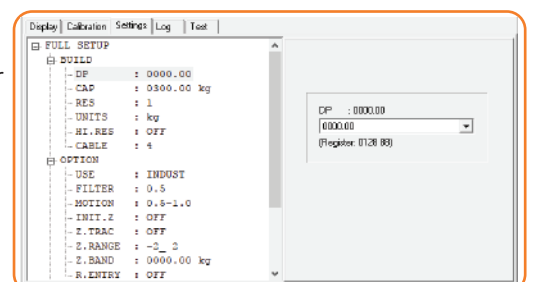

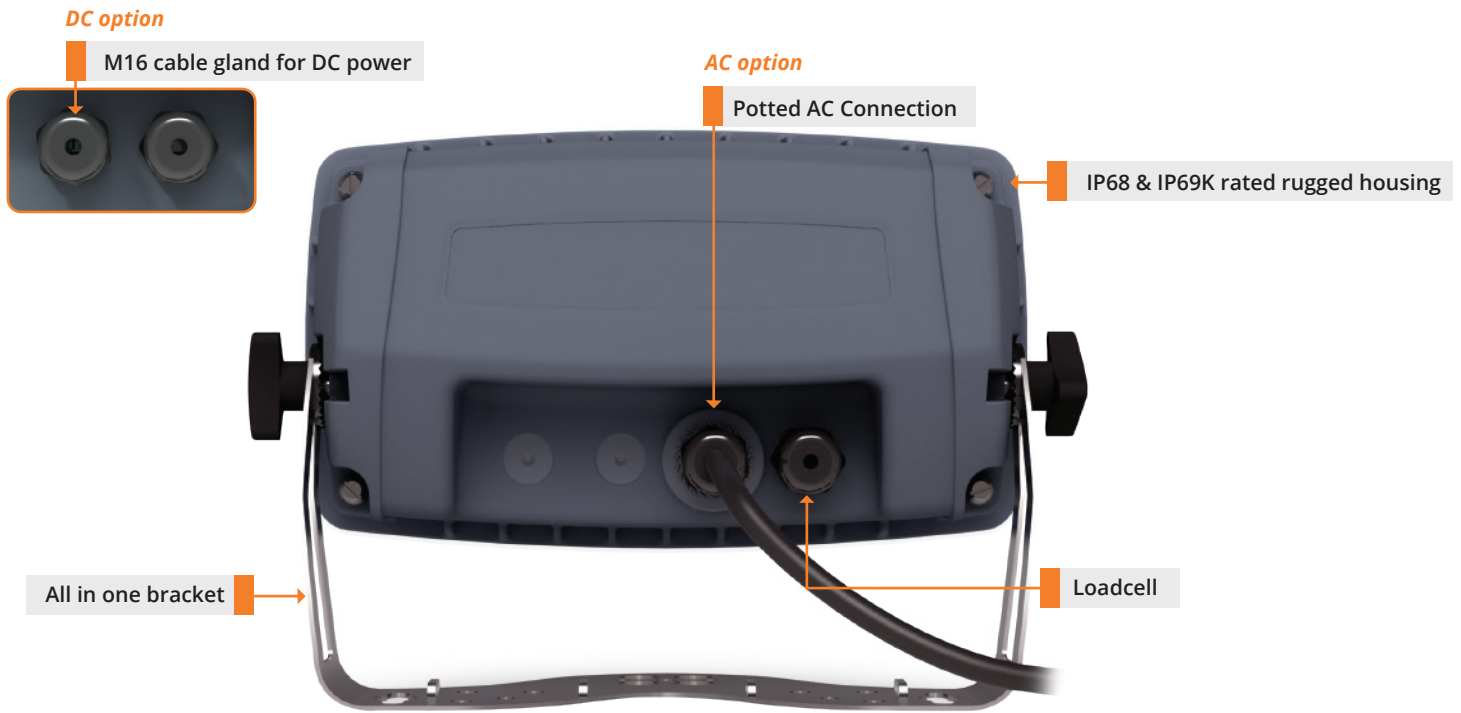

## rinLINK for establishing a temporary connection to a PC

The rinLINK provides an isolated optical serial connection directly on the front of the indicator. It is magnetically coupled for easy access in situ for updates/setup of the indicator, saving the installer time and effort.

The rinLINK can be used to download new firmware or provide the connection to the PC running Viewer for indicator configuration.



## Firmware Features

The X320 indicators have a firmware with full set point functionality and custom printing. Certain features are specifically available in the cross graded versions of K376 firmware. Cross grade firmware can be downloaded off the website and does not require a passcode.

Firmware Version		K376	K376-LIVE
Print (Serial RS232)		Advanced	
Function Key	Counting	.*	-
	Manual Hold	C	S
	Peak Hold	.*	-
	Totalisation	S	S
	Basic Check Weighing	S	-
Products	1	-	
Ring Network	S	S	
Bluetooth Accessory	A	A	
Set Point Output	3	-	
Units lb/ kg Switching	S	S	
Units lb/ kg/ oz/ g Switching	S	-	
Units on Power key or Function key	S	S	
Gravity Compensation	S	-	
Linearization	.*	-	
Animal Weighing	C	S	
Quick Calibration	S	S	

S - Standard Accessory A - Optional Accessory C - Cross Grade

\* - Contact us if you need this feature.

## Isolated outputs

- Over, Under, Pass
- High side driver up to 400 mA, allowing direct connection to PLCs and external actuators to be driven directly

## Check Weighing

- Enable/Disable function
- Choose to check on Displayed/Gross and Net weight
- Enter Over weight and Under weight
- Three coloured lights
- Annunciators on LCD
- Three outputs for external connections

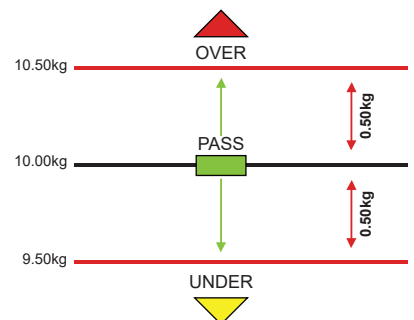

X300-713-252

### X320 Desk Mount / Post Mount

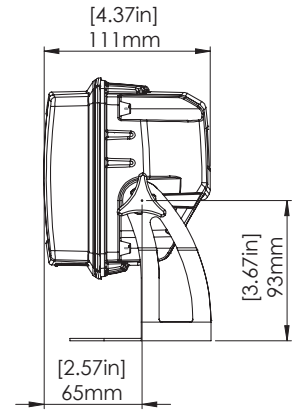
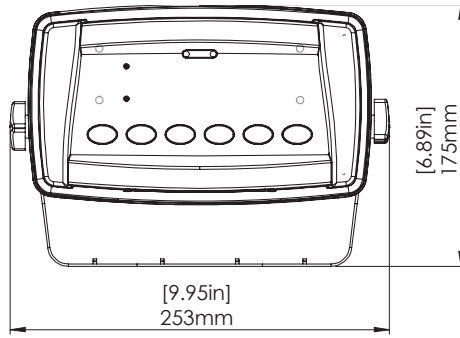
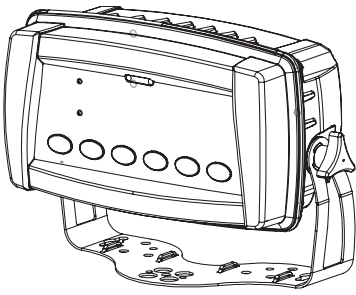

### X320 Wall Mount

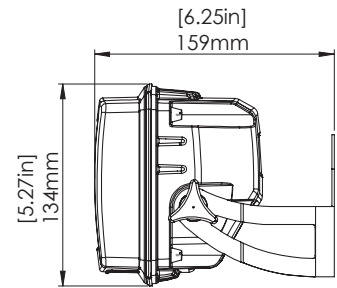
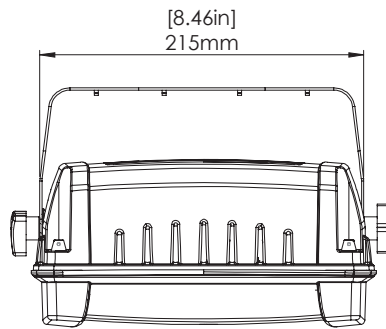
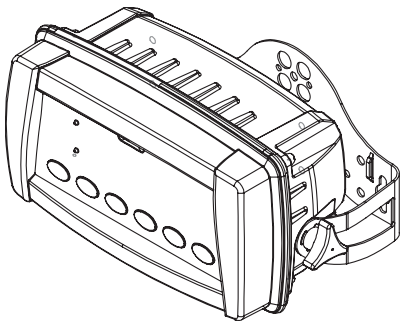

### X320 Under Shelf Mount

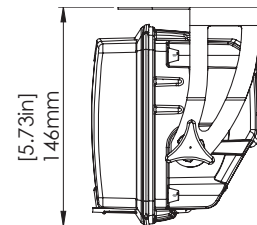
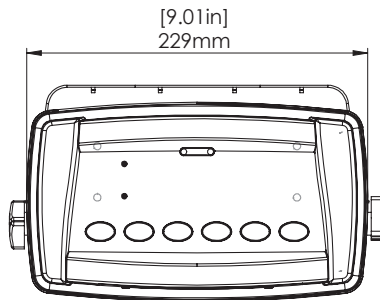
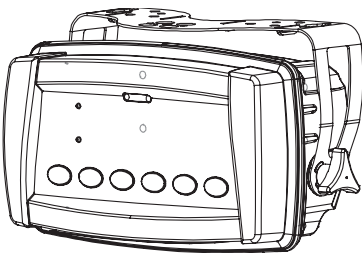

Local Dealer



Contact Us