

C510



rinstrum
SMART WEIGHING SOLUTIONS



Bringing together 25 years of smart weighing

The C510 industrial weight controller is the newest offering in Rinstrum's state-of-the-art C500 Series.

Ideal for truck weighing and process control applications, the C510 is a direct drop in replacement for WE2110 and WE2111 indicators from HBM as well as the Rinstrum 5000.

The C510 has a high-contrast LED display and a 5-button keypad, and has a host of connectivity options, such as USB (Host and Slave) and Ethernet. It also supports Modbus TCP and legacy ASCII. Functionality can be extended via support for add-on modules that may provide

- Up to 8 digital I/O
- Analogue output including two isolated I/O
- Isolated RS232 or RS485

The indicator can be set up using the C510 Viewer software (for PC) through Ethernet or a USB Slave port.

Features

- Compact ½ DIN standard housing
- 10,000d @ 0.5 μ V/d OIML R76
- 16 x 350 Ω load cells
- European WELMEC compliant legal for trade data storage
- Gross, Net, Tare, Print
- Programmable function key
- Diagnostics via Ethernet or USB slave
- Ethernet, USB, RS-485/RS-232 interfaces
- MODBUS TCP, Legacy ASCII

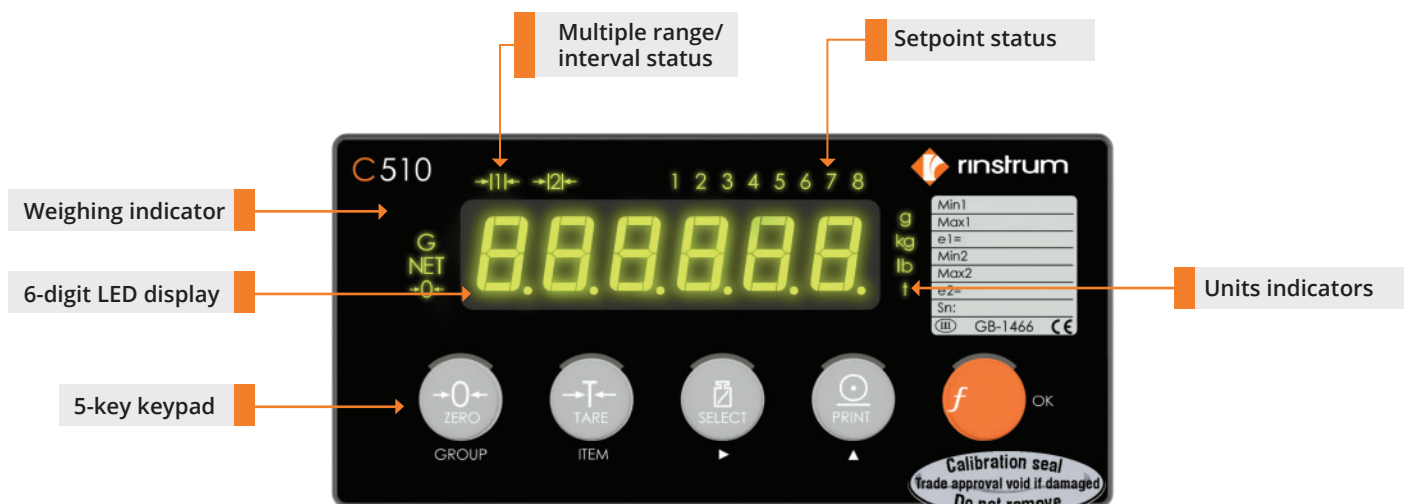
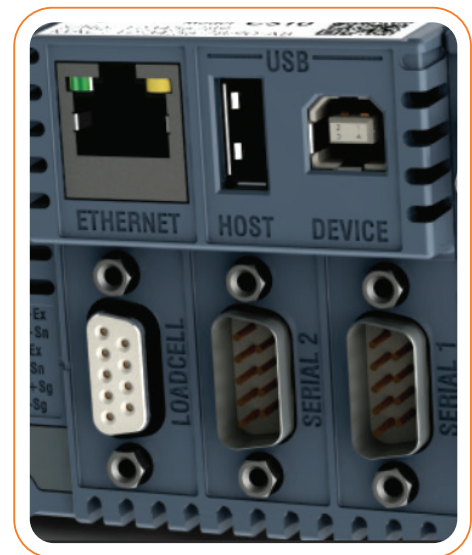

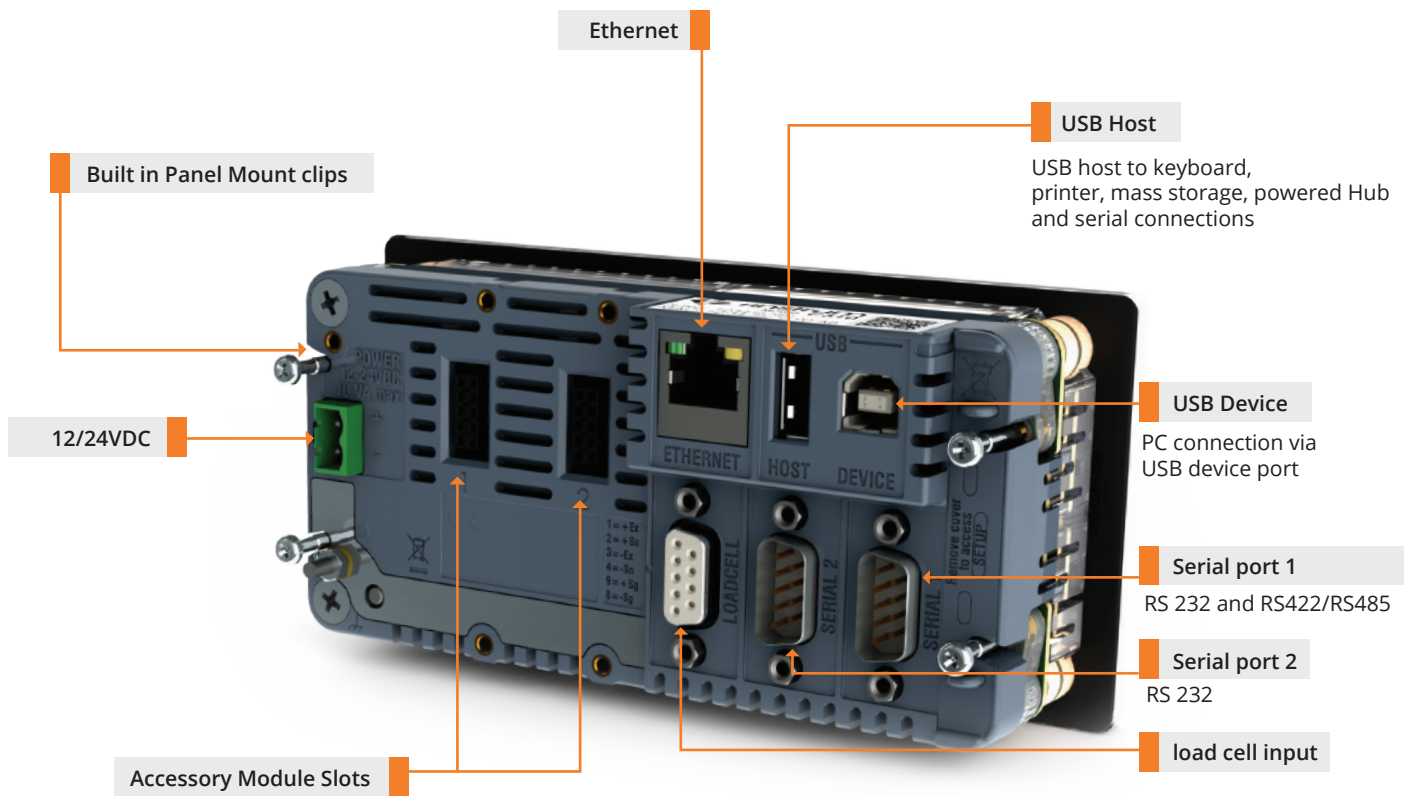

RS232/ RS232 Module	RS485/RS485 Module	AC Module	Analog Output	I/O Module
<ul style="list-style-type: none"> Electrically isolated RS232 serial communication Status LEDs 	<ul style="list-style-type: none"> Electrically isolated RS485 networking Status LEDs 	<ul style="list-style-type: none"> 110-240 VAC in 12 VDC out 	<ul style="list-style-type: none"> 4-20mA or 0-10V analog output Electrically isolated Fast 400Hz update 2 I/O 	<ul style="list-style-type: none"> 8 I/O Configure as input or output Electrically isolated Status LEDs Outputs – high current DC Active high I/O

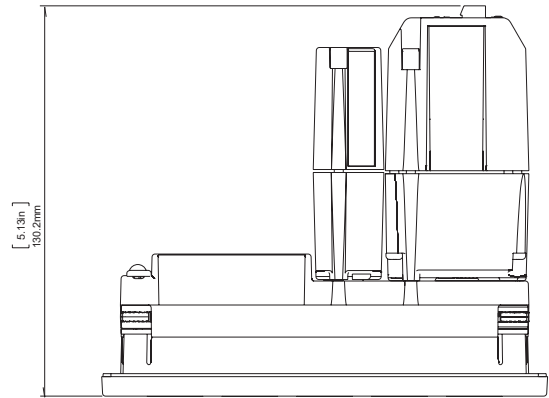
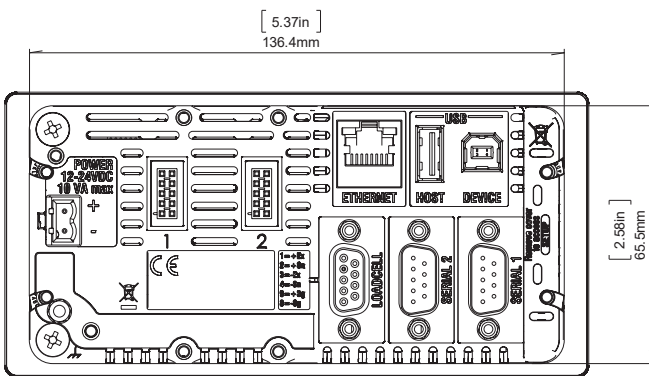
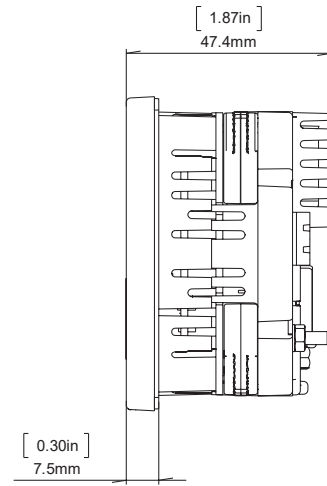
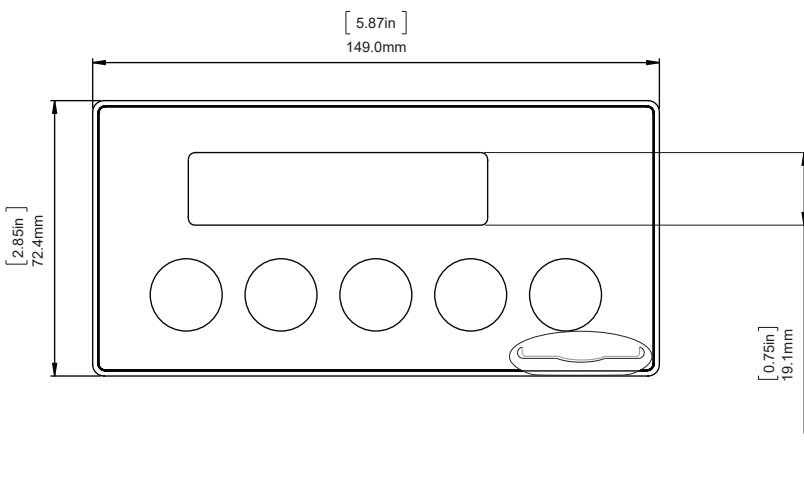

With AC Module and Analogue Module fitted

Local Dealer



Contact Us