

SMART WEIGHING SOLUTIONS

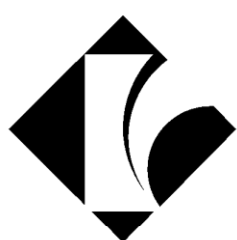

rinstrum

400 Series
(K410, K411, K412)
Batching Indicator
Reference Manual

R400-613-153

Copyright

All Rights Reserved. No part of this document may be copied, reproduced, republished, uploaded, posted, transmitted, distributed, stored in or introduced into a retrieval system in any form, or by any means (electronic, mechanical, photocopying, recording or otherwise) whatsoever without prior written permission of Rinstrum Pty Ltd.

Disclaimer

Rinstrum Pty Ltd reserves the right to make changes to the products contained in this manual in order to improve design, performance or reliability.

The information in this manual is believed to be accurate in all respects at the time of publication but is subject to change without notice. Rinstrum Pty Ltd assumes no responsibility for any errors or omissions and disclaims responsibility for any consequences resulting from the use of the information provided herein.

Table of Contents

1. INTRODUCTION6

1.1. The Manuals Set7

1.2. Document Conventions7

1.3. Software Comparison K410, K411 and K4127

2. SPECIFICATIONS8

3. INSTALLATION9

3.1. Introduction9

3.2. General Warnings9

3.3. Electrical Safety9

3.4. Cleaning9

3.5. Panel Mount Template9

3.6. Cable Connections10

3.7. DC Power (DC PWR +, DC PWR –)10

3.8. Load Cell Connection10

3.8.1. Load Cell Signals and Scale Build10

3.8.2. 4-Wire Connection11

3.8.3. 6-Wire Connection11

3.9. Auxiliary Connections12

3.9.1. RS-232 Serial12

3.9.2. RS-485 Serial14

3.10. Optical Communications15

3.11. Connecting Shields16

3.11.1. Cable Shield Connection and Earthing17

3.12. Regulatory Sealing Requirements17

3.13. Accessory Module connection17

4. BASIC OPERATION19

4.1. User Interface Display and Controls19

4.1.1. Display20

4.1.2. Keypad21

4.2. Power – On/Off22

4.2.1. Additional Information22

4.3. Stability Considerations22

4.4. Zero23

4.5. Tare23

4.6. Recipe24

4.7. Special Functions - Function Keys and External Inputs25

4.7.1. PRINT25

4.7.2. BLANK (Blanking Input)25

4.7.3. SINGLE25

4.7.4. TEST26

4.7.5. START26

4.7.6. PAUSE, ABORT, PSE.ABT, ST.PS.AB, SUSPND26

4.8. Numeric Keypad – White Commands27

4.8.1. System Time and Date (Clock - 1 key)27

4.8.2. Display View (View - 2 key)27

4.8.3. Reports (Report - 3 key)27

4.8.4.	View and Clear Totals (Total - 4 key).....	28
4.8.5.	View and Clear ID Names (ID – 5 key).....	29
4.8.6.	View and Change Pulse Timers (Timers - 6 key)	30
4.8.7.	View and Change Setpoint Targets (Target - 7 key).....	30
4.8.8.	Flight Settings (Flight – 8 key)	31
4.8.9.	Tolerance (TOL - 9 key).....	32
4.8.10.	Keypad Lock (Lock - . key)	32
4.8.11.	Alibi (+/- key).....	33
4.8.12.	Accessory Modules (Acc – 0 key).....	34
4.8.13.	Up, Down, OK keys: Products	35
5.	INSTRUMENT CONFIGURATION	39
5.1.	Accessing Full/Safe Setup	39
5.1.1.	Full Setup.....	39
5.1.2.	Safe Setup	39
5.1.3.	Setup Display Prompts	39
5.1.4.	Exiting Full or Safe Setup	40
5.2.	Passcodes and Key Lock.....	40
5.2.1.	Full Setup Passcode	40
5.2.2.	Safe Setup Passcode	40
5.2.3.	Operator Passcode	40
5.2.4.	Setup Lock-Out.....	40
5.3.	Menu Navigation	41
5.4.	Data Entry	41
5.4.1.	Changing Data	42
5.4.2.	Numeric Entry	42
5.4.3.	Selections and Options	42
5.4.4.	Strings.....	43
6.	SCALE CONFIGURATION	44
6.1.	Scale Parameters (SCALE:BUILD).....	44
6.2.	Scale Options (SCALE:OPTIONS)	45
6.2.1.	Industrial versus Trade Modes (USE).....	45
6.2.2.	Filtering Techniques (FILTER).....	45
7.	CALIBRATION (SCALE:CAL).....	46
7.1.1.	Calibration Counter	46
7.1.2.	Digital Calibration with Test Weights (ZERO and SPAN)	46
7.1.3.	Calibration with Direct mV/V Entry (DIR.ZER and DIR.SPN).....	48
7.1.4.	Using Linearisation (ED.LIN and CLR.LIN).....	49
8.	NETWORK PROTOCOL.....	51
8.1.	Introduction	51
8.2.	Network Protocol.....	51
8.2.1.	Basic Format.....	51
8.2.2.	Termination	52
8.2.3.	Error Handling.....	53
8.2.4.	Ring Network Enhancement	53
8.2.5.	Calibrating an instrument over a network	54
8.3.	Network Protocol BARCODE (K411 and K412 only)	54
8.4.	Protocol B Examples.....	55
9.	AUTOMATIC WEIGHT OUTPUT	58
9.1.	Overview	58

9.2.	Auto Weight Format String.....	58
10.	PRINTING.....	60
10.1.	Overview	60
10.2.	Print ID	60
10.3.	Record printouts.....	60
10.4.	Batch printouts	61
10.5.	Report printouts.....	63
10.6.	Custom printing	64
11.	SETPOINTS	65
11.1.	Overview	65
11.2.	Outputs.....	65
11.3.	Common Settings.....	65
11.4.	Weigh in (OVER) Setpoints and Weigh Out (UNDER) Setpoints	66
11.4.1.	Additional Settings	67
11.4.2.	Status Based Setpoint Types.....	68
11.5.	Batching Based Setpoint Types	68
11.6.	Logic Setpoint Types.....	69
12.	ANALOGUE OUTPUT	72
12.1.	Overview	72
12.2.	Configuration of Hardware	72
12.2.1.	Configuration.....	72
12.2.2.	Calibration.....	72
12.2.3.	Testing	72
12.3.	Analogue Weight Transmission	72
13.	BATCHING.....	73
13.1.	Terminology	73
13.2.	Predefined Applications (K411 and K412 only).....	73
13.3.	Stage Types	73
13.3.1.	FILL Stage	74
13.3.2.	DUMP Stage	75
13.3.3.	PULSE Stage.....	76
13.4.	Batching specific keys.....	77
13.4.1.	<RECIPE> key - recipe information	77
13.4.2.	Timers (6 key) – time duration of PULSE stages.....	77
13.4.3.	Flight (8 key) – in-flight and preliminary targets for each material	77
13.4.4.	Tolerance (9 key) – high and low tolerance for each fill stage.....	78
13.5.	Setpoints	78
13.6.	Special Functions.....	78
13.7.	General Setup	79
13.8.	Stage Specific Setup.....	80
13.8.1.	Outputs	80
13.8.2.	Inputs	80
13.8.3.	Delays	81
13.8.4.	FILL Correction (Jogging and In-flight)	81
13.8.5.	DUMP Correction.....	82
13.9.	Pause and Abort	82
13.10.	Batching Example	82
14.	SETUP MENUS.....	85
14.1.	GEN.OPT (General options)	85

14.1.1.	DATE.F (Date format)	85
14.1.2.	PCODE (Security passcodes).....	85
14.1.3.	KEY.LOC (Key Function Access Control).....	86
14.1.4.	DISP (Display options).....	87
14.1.5.	ID.NAME (ID name strings)	87
14.1.6.	POWER (Power options)	88
14.1.7.	STR.EDT (String editor default mode).....	88
14.1.8.	USR.DEF (Set all non-calibration settings to defaults)	88
14.2.	H.WARE (Hardware Configuration & Test).....	88
14.2.1.	LC.HW	88
14.2.2.	SER1.HW, SER2.HW	89
14.2.3.	IO.HW	90
14.2.4.	ANL.HW	91
14.2.5.	DSD.HW	91
14.2.6.	ETH.HW.....	91
14.2.7.	ETH.DEF (Set the M4221 Ethernet module to defaults).....	92
14.3.	SCALE (Load cell options and calibration).....	93
14.3.1.	BUILD (Scale parameters).....	93
14.3.2.	OPTION (Scale options)	94
14.3.3.	CAL (Scale calibration)	95
14.3.4.	QA (QA alarm)	95
14.4.	FUNC (Special functions).....	96
14.4.1.	NUM (Number of special functions)	96
14.4.2.	SFn: TYPE (Function Types).....	96
14.4.3.	SFn: KEY (Function Key / Remote Input)	96
14.4.4.	SFn: PRINT (Printing Functions)	97
14.4.5.	SFn: SINGLE (Single Serial Output Functions)	97
14.4.6.	SFn: BLANK (Blanking Functions).....	97
14.4.7.	SFn: START, SFn: PAUSE, SFn:ABORT, SFn PSE.ABT, ST.PS.AB, SFn: SUSPND (Batching Functions)	98
14.4.8.	SFn: THUMB (Thumbwheel Product Selection)	99
14.4.9.	SFn: REM.KEY (Remote Key Functions)	99
14.4.10.	SFn: REPORT (Report Functions) :.....	100
14.5.	SER.NET (Network communications).....	100
14.6.	SER.AUT (Automatic transmit)	101
14.6.1.	NUM (Number of Automatic Transmissions)	101
14.6.2.	AUTO.n (Automatic Output Configuration)	101
14.7.	PRINT (Printouts).....	102
14.7.1.	NUM (Number of printouts).....	102
14.7.2.	HEADER (Print header)	102
14.7.3.	FOOTER (Print footer)	102
14.7.4.	PAGE (Print page options).....	103
14.7.5.	SPACE (Print blank space options)	103
14.7.6.	PRINT.n ... (Printout options)	104
14.8.	SETP (Setpoints)	105
14.8.1.	NUM (Number of setpoints)	105
14.8.2.	SETP1 ... SETP8 (Setpoint options)	105
14.9.	BATCH.....	108
14.9.1.	APP (Applications) (K411 and K412 only)	108
14.9.2.	GEN (General).....	109

14.9.3.	MAT (Material)	111
14.9.4.	STAGES	111
14.9.5.	STAGE.n:FILL.....	112
14.9.6.	STAGE.n:DUMP	114
14.9.7.	STAGE.n: PULSE	115
14.10.	ANL.OUT (Analogue Output)	116
14.11.	End (Save and exit).....	116
15.	APPENDIX 1: DIMENSIONS	117
15.1.	Dimensions	117
15.2.	Legal Sealing Details	119
15.2.1.	Electronic Seal	119
15.2.2.	Trade Label.....	119
15.2.3.	Lead Seals	120
15.2.4.	Destructible Sticker Seals	121
APPENDIX 2:	PRINT AND AUTOMATIC TRANSMISSION TOKENS	122
15.3.	ASCII codes	122
15.4.	Tokens	123
15.4.1.	Non-paged generic tokens.....	123
15.4.2.	Page tokens	123
15.4.3.	Page 0, 7 tokens: Weight Information.....	124
15.4.4.	Page 1, 2 tokens: Current Stage and Batch Information	125
15.4.5.	Page 4, 6 tokens: Product and Grand Total Information.....	125
15.4.6.	Page 8 Tokens: Material Totals	126
15.4.7.	Format tokens.....	126
16.	APPENDIX 3: COMMUNICATIONS REGISTERS.....	128
17.	APPENDIX 4: SETUP MENU QUICK REFERENCE	135
18.	APPENDIX 5: ERROR MESSAGES	140
18.1.	Overview	140
18.2.	Weighing Errors	140
18.3.	Setup Errors	140
18.4.	Diagnostic Errors.....	141
18.4.1.	Calibration Errors	142
18.5.	Pause Conditions	143
19.	GLOSSARY.....	144
19.1.	Glossary Terms.....	144
19.2.	List of Figures.....	145
19.3.	List of Tables.....	145
20.	INDEX.....	146

1. Introduction

This instrument is a precision digital indicator designed for gain in weight batching applications. It supports up to 32 input/outputs.

It may be operated from either a DC power source (12 VDC to 24 VDC) or AC power (optional 110 – 240 VAC). There is a soft power on/off function that retains memory of its state. Once an instrument is turned on it will automatically start up again if the external power is interrupted.

The instrument provides zero, tare and recipe on the fixed function keys and supports special functions (e.g. start, pause, remote key etc.), via three (3) user definable function keys and external inputs. Operator functions (clock, view, report etc) and editing functions are provided on the alpha/numeric key pad. It is equipped with an NVRAM store to ensure day-to-day operating settings (e.g. zero, tare and clock) are retained when power is removed.

The indicator supports optical communications as a standard which allows a temporary isolated communications link to be established with a PC. Software upgrades, the use of computerised setup and calibration can then be done using a PC. The RS-232 communications port can be used for printer driving, connection to a remote display or PC. The RS-485 transmit only communications port can be used for remote displays. There is a built-in clock for date-stamping printed outputs.



Figure 1: Weight Indicator

1.1. The Manuals Set

This manual is part of a set of manuals covering the setup and operation of the instrument. The set includes the following:

- **Reference Manual** - Contains detailed information on calibration and setup. This manual is intended for use by Scale Technicians who are installing the instrument.
- **Operator Manual** - Aimed at the operator of the instrument and covers the day-to-day operation of the instrument.
- **Quick Start Manual** - Intended for Scale Technicians who are familiar with the instrument and simply need a quick reference to menu options and connection diagrams, etc.

1.2. Document Conventions

The following document conventions (typographical) are used throughout this Reference Manual.

Bold Text	Bold text denotes words and phrases to note.
<Key>	<Key> denotes a Keypad key. Note: In the Specifications section the < symbol means less than and the > symbol means greater than .
^	This symbol denotes one space when describing serial output formats.

1.3. Software Comparison K410, K411 and K412

The table below only lists the features that vary between each type of software.

Feature	K410	K411	K412
No. of Materials	1	6	20
Barcode protocol		✓	✓
Materials set per product			✓

2. Specifications

Performance	
Resolution	Up to 100,000 divisions, minimum of 0.25 μ V/division
Zero Cancellation	+/- 2.0mV/V
Span Adjustment	0.1mV/V to 3.0mV/V
Stability/Drift	Zero: < 0.15 μ V/ $^{\circ}$ C (+ 10ppm of deadload max) Span < 10 ppm/ $^{\circ}$ C, Linearity < 20ppm, Noise < 0.2 μ Vp-p
Excitation	7.4 volts for up to 16 x 350 or 32 x 700-ohm load cells (4-wire or 6-wire plus shield) Maximum total load cell resistance: 1,000 ohms
A/D Type	24bit Sigma Delta with \pm 8,388,608 internal counts
Operating Environment	Temperature: -10 to +50 $^{\circ}$ C ambient Humidity: <90% non-condensing Storage: -20 to +50 $^{\circ}$ C ambient IP65 when panel mounted or with rear boot (otherwise IP40)
Case Materials	ABS, Silicon Rubber, Nylon, Acrylic (no halogen used)
Packing Weights	Basic Indicator: 0.7kg
Digital	
Display	LCD with 4 alpha-numeric displays and LED backlighting: Primary display: 6 x 28.4mm high digits with units and annunciators 2 nd display: 9 x 17.6 mm digits with units 3 rd display: 8 x 6.1 mm digits 4 th display: 4 x 7.6 mm digits
Setup and Calibration	Full digital with visual prompting in plain messages
Digital Filter	Sliding window average from 0.1 to 30.0 seconds
Zero Range	Adjustable from +/- 2% to +/- 20% of full capacity
Power Input	
Standard Power Input	12 to 24VDC (15 VA max) - ON/OFF key with memory feature
Variants	
M4101 AC	AC power supply Input: 110/240VAC 50/60Hz Output: 12VDC 15VA
M4102 Battery	2.5AH NiMH rechargeable battery pack Charger Input: 110/240VAC 50/60Hz Output: 12VDC
Features	
Optical Data Communications	Magnetically coupled optical communications support. Optional conversion cable connects directly to a standard USB or RS-232 port.
Correction	10-point linearity correction
Serial Outputs	RS-232 serial port for remote display, network or printer supports. RS-485 transmit only for remote display Transmission rate: 1200, 2400, 4800, 9600, 19200 or 57600 baud
3 assignable function keys	Printing, start, pause and abort batching
Battery Backed Clock Calendar	Battery life 10 years minimum
Approvals	FCC, CE, C-tick, Check trade approvals

3. Installation

3.1. Introduction

The following steps are required to set up the indicator.

- Inspect indicator to ensure good condition.
- Use connection diagrams to wire up load cell, power and auxiliary cables as required.
- Insert any accessory modules that are being used.
- Use the drill hole template provided for hole locations.
- Connect power to indicator and press **<POWER>** key to turn the instrument on.
- Refer to 14 Setup Menus page 85 for information on configuring the instrument.
- To turn instrument OFF press and hold **<POWER>** key for three seconds (until display blanks).

3.2. General Warnings

- Indicator not to be subject to shock, excessive vibration, or extremes of temperature (before or after installation).
- Inputs are protected against electrical interference, but excessive levels of electromagnetic radiation and RFI may affect the accuracy and stability.
- The instrument should be installed away from any sources of excessive electrical noise.
- The load cell cable is particularly sensitive to electrical noise and should be located well away from any power or switching circuits.
- For full EMC or for RFI immunity, termination of cable shields and correct earthing of the instrument is essential.

3.3. Electrical Safety

- For your protection all mains electrical hardware must be rated for environmental conditions of use.
- Pluggable equipment must be installed near an easily accessible power socket outlet.
- To avoid the possibility of electric shock or damage to the instrument, always switch off or isolate the instrument from the power supply before maintenance is carried out.

3.4. Cleaning

To maintain the instrument, never use harsh abrasive cleaners or solvents. Wipe the instrument with a soft cloth **slightly** dampened with warm soapy water.

3.5. Panel Mount Template

The panel mount template is supplied with the instrument. It shows the location of the rectangular cut-out and the four mounting screws.

3.6. Cable Connections

All cable connections are made to the rear of the instrument using pluggable screw terminals. It is not necessary to tin the ends of the wires with solder or to add crimp ferrules to the wires, however these techniques are compatible with the terminals.

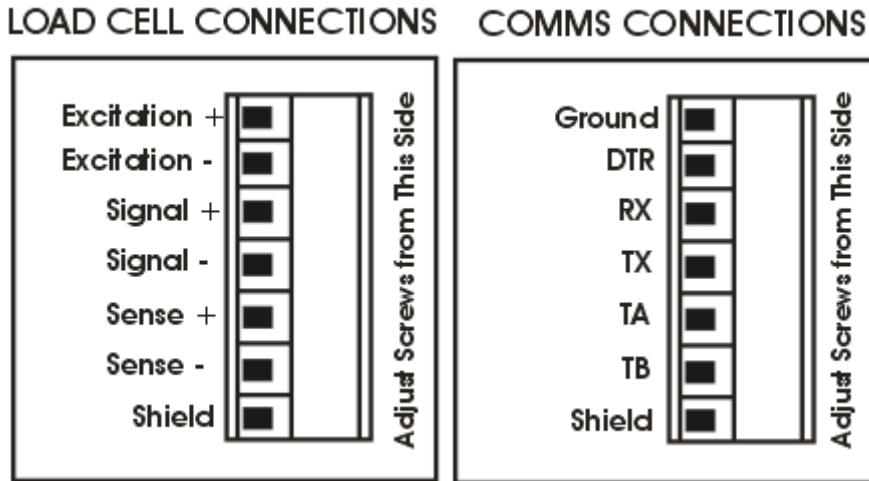

Figure 2: Cable Connections

3.7. DC Power (DC PWR +, DC PWR -)

The DC supply need not be regulated, provided that it is free of excessive electrical noise and sudden transients. The instrument can be operated from a high-quality plug-pack as long as there is sufficient capacity to drive both it and the load cells.

3.8. Load Cell Connection

3.8.1. Load Cell Signals and Scale Build

Very low output scale bases may be used but may induce some instability in the weight readings when used with higher resolutions. Generally speaking, the higher the output, or the lower the number of divisions, the greater the display stability and accuracy.

The instrument can display the millivolt-per-Volt (H.WARE:LC.HW:MVV) reading which can be used to check scale base signal output levels. For more information, refer to 14.2.1 LC.HW page 88.

The instrument may be connected for either 4-wire or 6-wire operation. Use 4-wire when external SENSE connections are not available. Refer to 14.3.1 BUILD (Scale parameters) page 93 for setup menu.

3.8.2. 4-Wire Connection

The minimum connectivity requirements are the connection of four wires (i.e. \pm Excitation and \pm Signal). Internally the instrument has a precision analogue switch that can be used to connect the Sense+ and Sense- lines directly to the Excitation+ and Excitation- lines.

Any addition to the load cell manufacturer's cable length using 4-wire connection is only recommended for short cable runs. Where long additions to cable lengths are needed, a 6-wire extension is required.

The BUILD:CABLE option must be set to **4-WIRE** to allow for 4-wire connection, refer to 14.3.1 BUILD (Scale parameters) page 93.

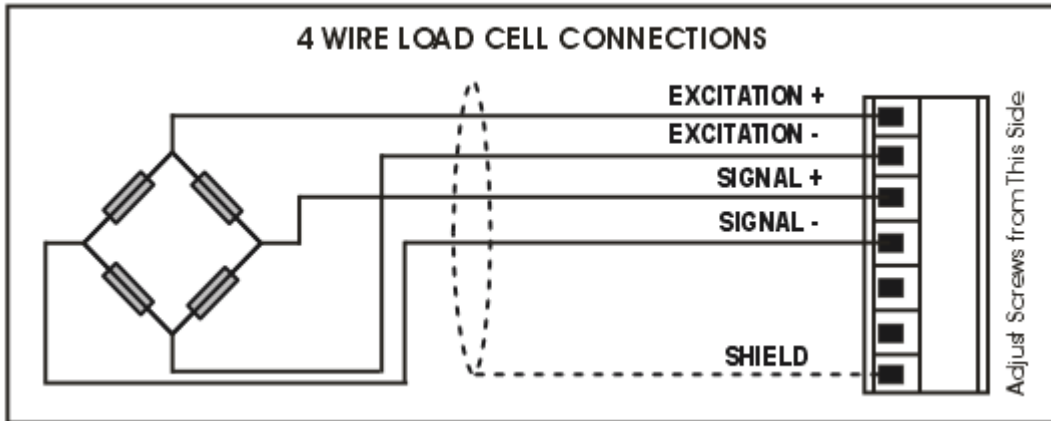

Figure 3: 4-Wire Connections

3.8.3. 6-Wire Connection

The excitation and signal lines are connected the same as for a 4-wire installation. The extra two wires (Sense + and -) should be connected to the Excitation + and - lines as close as possible to the load cell itself. Typically, these connections are made in a load cell termination box.

The BUILD:CABLE option must be set to **6-WIRE** to allow for true 6-wire connection, refer to 14.3.1 BUILD (Scale parameters) page 93.

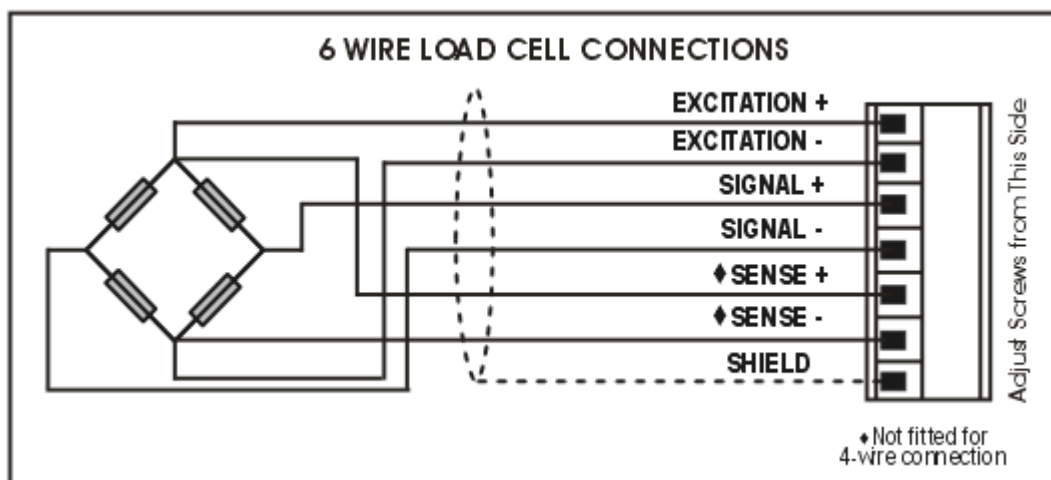

Figure 4: Load cell Connections

3.9. Auxiliary Connections

This section provides diagrams to illustrate the communication connections.

3.9.1. RS-232 Serial

Direct Personal Computer Link (RX, TX, GND)

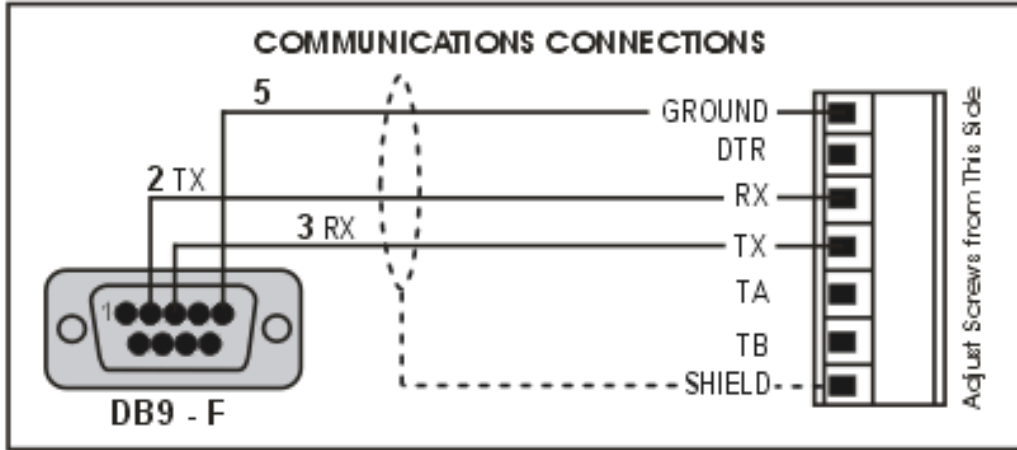

Figure 5: RS-232 - Instrument to PC using COM Port (DB9)

Printer Connections (TX, DTR and GND)

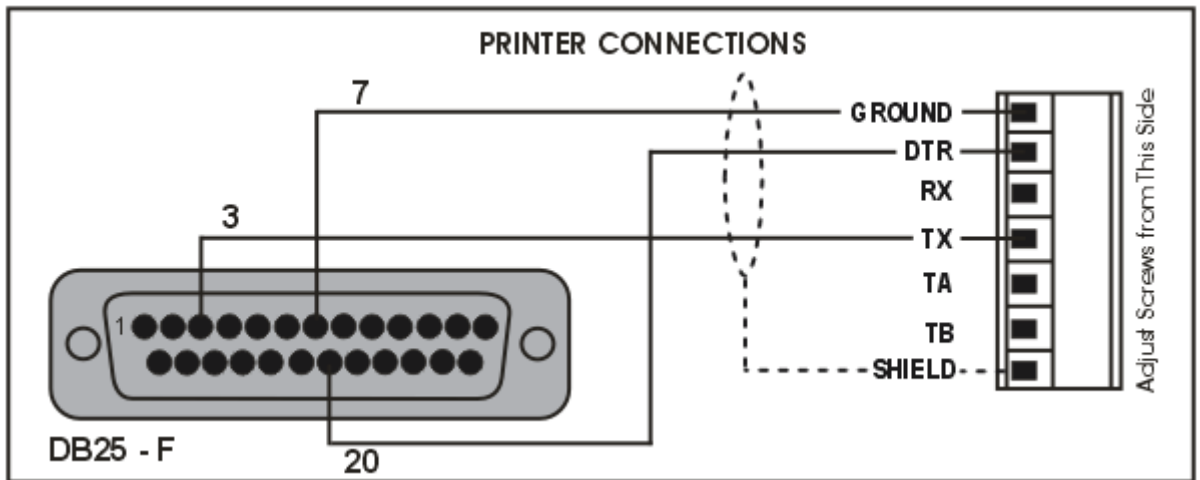

Figure 6: RS-232 – Instrument to Printer (DB25)

Remote Display (TXD, GND)

Refer to documentation supplied with the remote display for connection details. Connect RX on the remote display with TX on the instrument and connect the RS232 GND signals together.

Ring Networks: Multiple Instruments to PC (RXD, TXD, GND)

Instruments with software revision V2.31+ can be configured in a Ring Network via a M42xx module (software revision 1.01+). This feature is not available on the inbuilt serial port. This also requires an enhancement in the PC software.

The Short Ring Network layout (Figure 7) can be used in situations up to a total cable run length of about 150m (500 ft.) at 9600 baud in a clean EMC environment.

If there are communications errors, or for longer cable runs, lower the baud rate to 4800 or 2400, and/or use the Long Ring Network in Figure 8, which uses a separate return path from the 'Last Instrument' to the PC.

When operating in a Ring Network, the Instruments must have:

- same serial port options, i.e., baud, parity, data bits, stop bits;
- unique addresses.

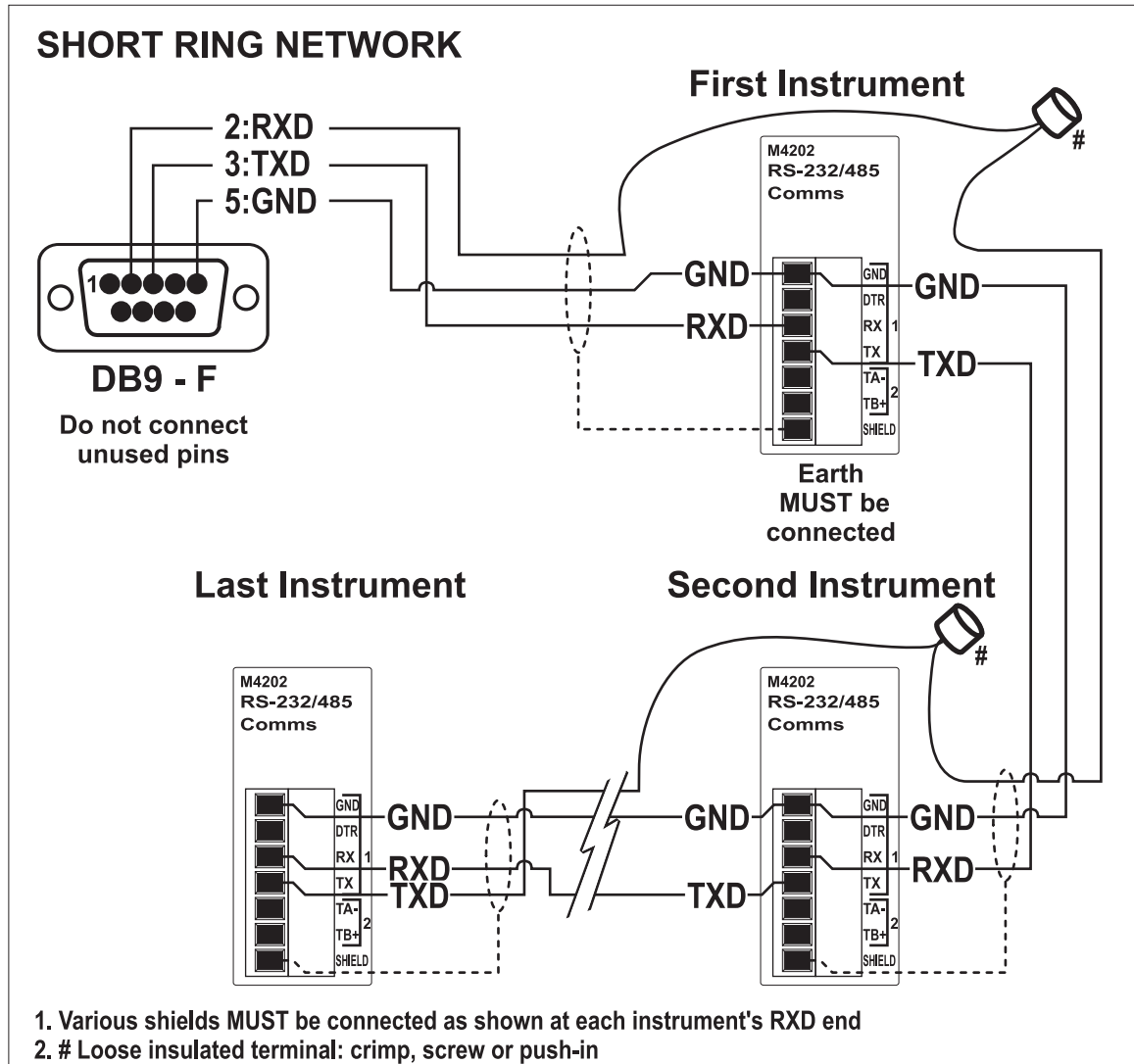

Figure 7: RS-232 Short Cable Runs (Ring Network using COM Port)

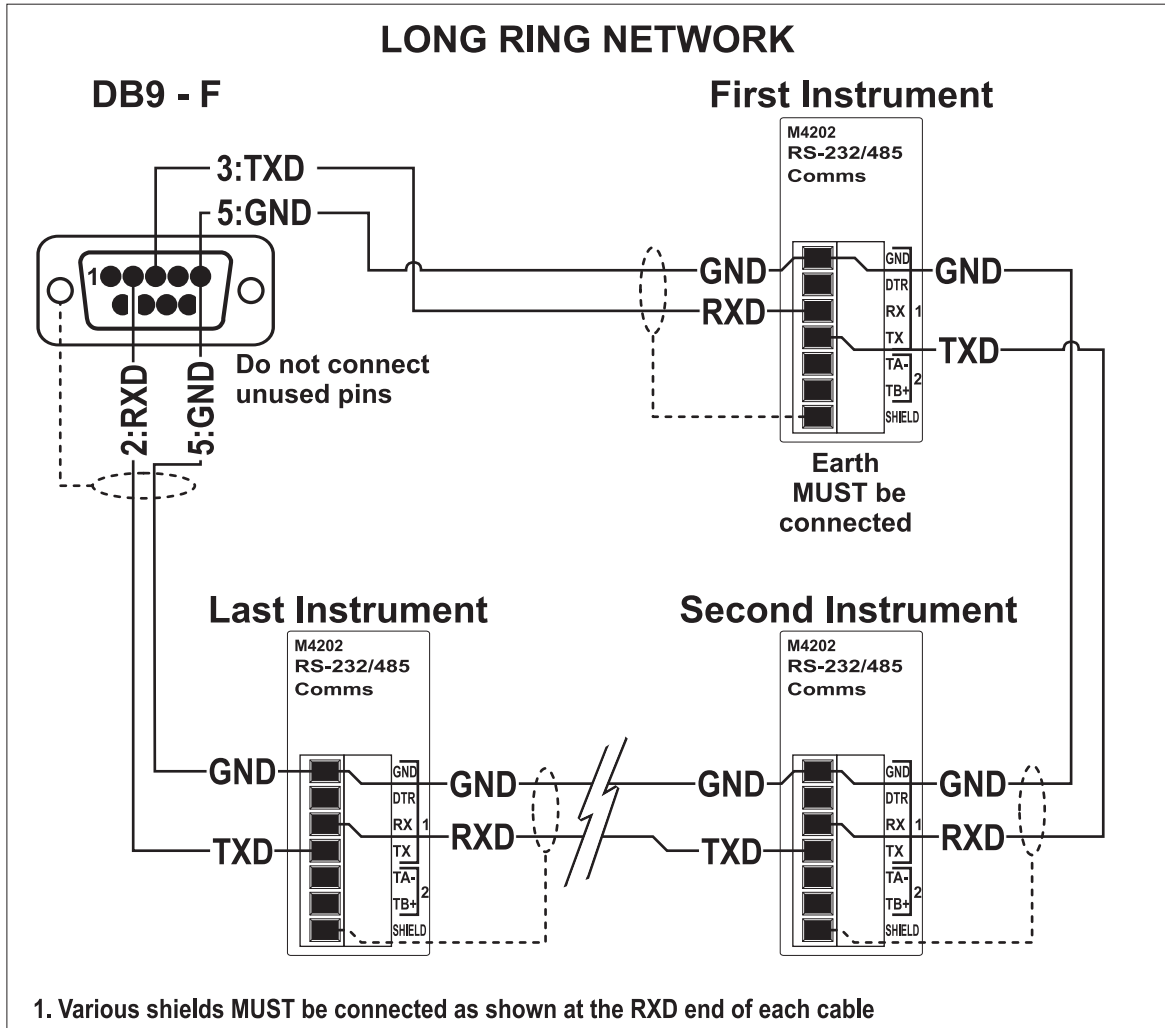

Figure 8: RS-232 Long Cable Runs (Ring Network using COM Port)

3.9.2. RS-485 Serial

Remote Display (TA, TB)

RS485 is recommended for communicating over distances longer than a few metres. Connect TA to RA and TB to RB on the remote display.

Multi-drop Networks: Multiple instruments to PC (TA, TB, RA, RB)

Using a RS485 module, it is possible to implement a multi-drop network. This feature is not available on the inbuilt serial port.

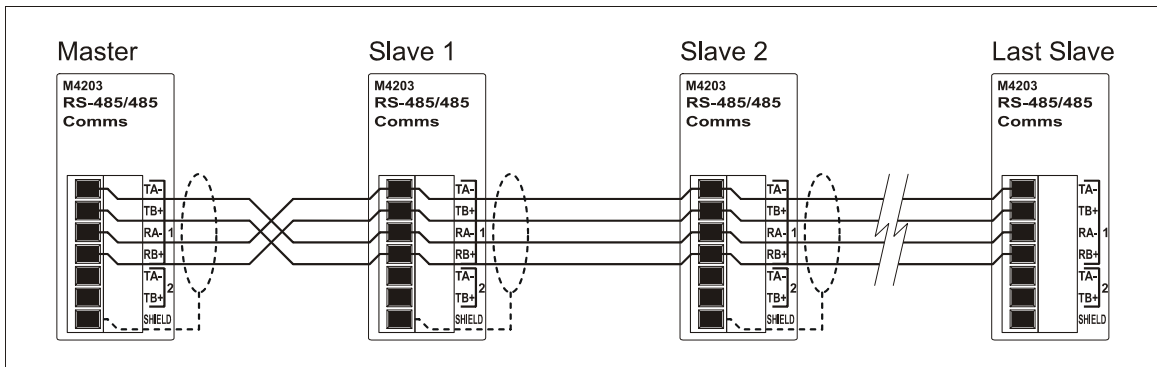

Ring Networks: Multiple instruments to PC (TA, TB, RA, RB)

Instruments with software revision v2.40+ can be configured in a ring network via a M42xx module (software revision v1.01+). This feature is not available on the in-built serial port. This also requires an enhancement in the PC software.

3.10. Optical Communications

A temporary infrared communications link can be established between the instrument and a PC using an optional opto-link cable. This connection can be used to transfer setup and calibration information from a PC or to download software upgrades.

The PC end of the cable is a standard female DB9 RS232 or USB connector. The instrument end of the cable attaches to the left side of the instrument display.

WARNING

The optical coupling head contains a strong magnet and should not be placed near any magnetic storage media (e.g. credit cards, floppy disks etc.)



Figure 9: Optical Communications attachment

3.11. Connecting Shields

To obtain full EMC or for RFI immunity, cable shields **MUST** be connected and the earth lug on the rear of the instrument must be grounded.

Figure 10 illustrates an example of possible connections. Also shown are the connecting cables restrained using cable ties fastened by screws into the rear of the unit.

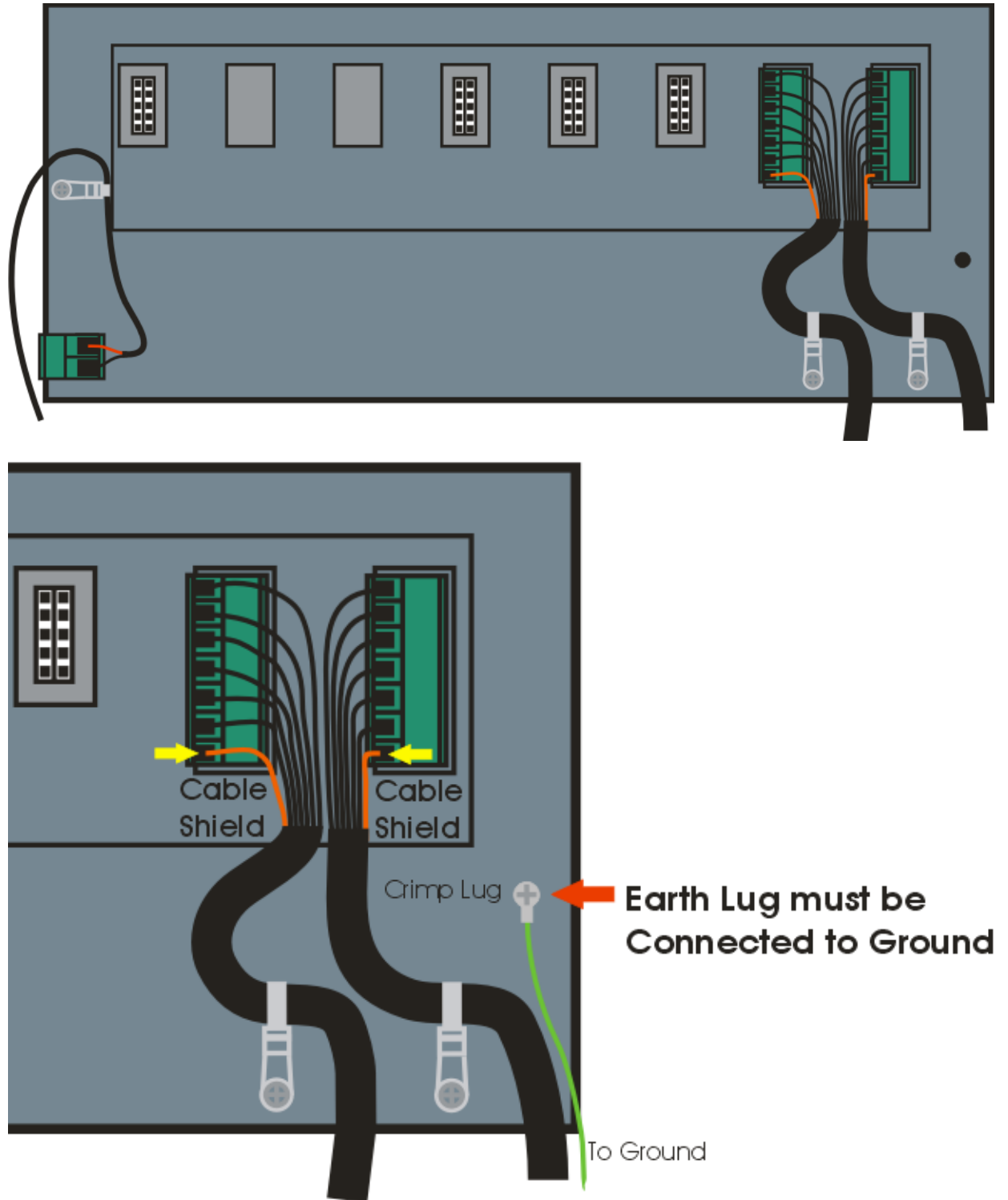

Figure 10: Cable Shield Connection

3.11.1. Cable Shield Connection and Earthing

- Care should be taken when connecting shields to maximise EMC or RFI immunity and minimise earth loops and cross-talk (interference) between instruments.
- For full EMC or for RFI immunity, termination of the cable shields to the connectors is very important. The earth lug of the instrument must be separately connected to ground potential via a reliable link.
- The AC power module directly connects the earth lug to the Earth Pin on the power supply. In installations where earth is available on the power cable, instrument earthing can be done with this connection.
- The instrument should only be connected to earth via a single reliable link to avoid earth loops.
- Where each instrument is separately earthed, interconnecting cable shields should be connected at one end only.
- **Caution:** Some load cells connect the cable shield directly to the load cell (and therefore the scale base). Connection of the load cell cable shield in this situation may be site specific.

3.12. Regulatory Sealing Requirements

To comply with regulatory sealing requirements and ensure instruments are not accidentally or deliberately tampered with, it is important that proper sealing procedures be adhered to. These are discussed in 15.2 Legal Sealing Details page 119.

3.13. Accessory Module connection

Up to four (4) accessory modules can be plugged into the rear of the instrument. There are many types of modules which can be used providing additional features such as:

- power supply options, e.g. mains power or batteries
- communications ports, e.g. Ethernet or RS485 networking
- analogue outputs, e.g. 4-20mA or 0-10V
- digital inputs and digital outputs, e.g. external buttons or setpoint outputs
- Alibi memory, e.g. DSD functionality

The slots on the rear of the instrument are marked as 1, 4, 5 and 6 (note 2 and 3 are not available).

<p>Caution: Instrument must be switched off before connecting or disconnecting accessory modules.</p>
--

Basic steps for installation of modules:

- Check instrument switched off.
- Connect module. Refer to the specific module manual for wiring details.
- Switched instrument on.
- Enter safe setup or full setup.
- Go to applicable area in setup menu and allocation functions to hardware as required.
- Review hardware allocation and test. Refer to 14.2 H.WARE (Hardware Configuration & Test) page 88.

The details of the accessories can be viewed using the Acc key (long press of the 0 key), refer to 4.8.12 Accessory Modules (Acc – 0 key) page 34.

Power supply options can only be connected in the left position (Slot 1: SL-1). Other modules can be connected in any position.

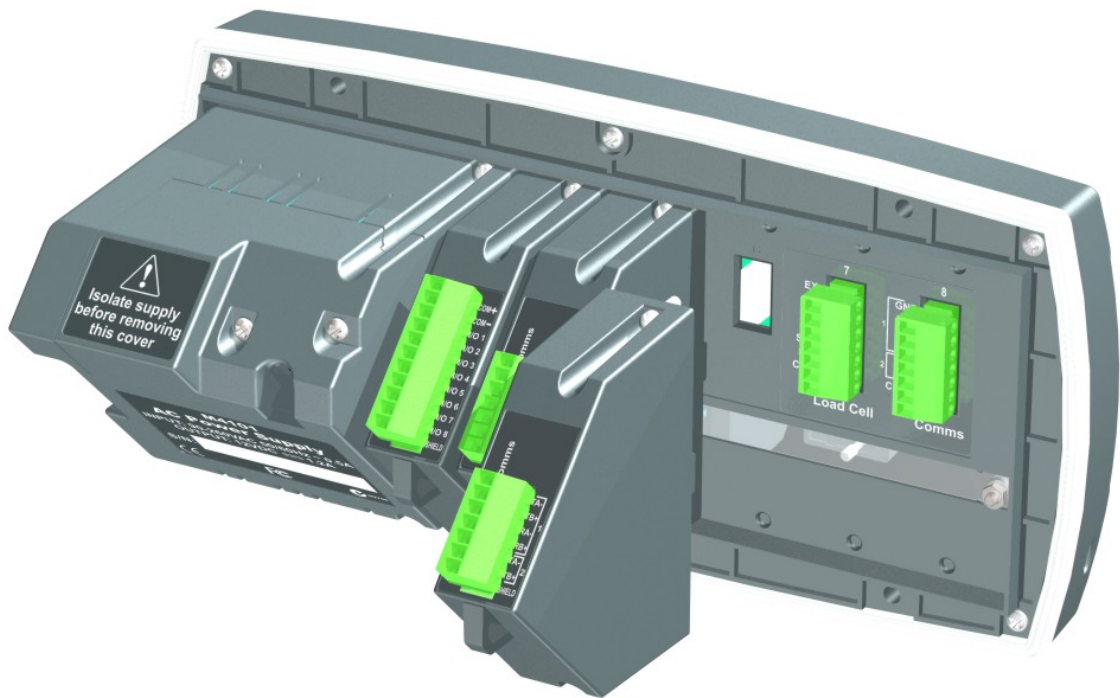

Figure 11 - Instrument Module View

4. Basic Operation

4.1. User Interface Display and Controls



Code	Description	Reference Section
1	Display	4.1.1
2	Opto-link connection point	
3	Power Key	4.2
4	Function Keys (Fixed)	4.4, 4.5 and 4.6
5	Function Keys (user defined)	4.7
6	Numeric Keypad	4.1.2 and 4.8

4.1.1. Display

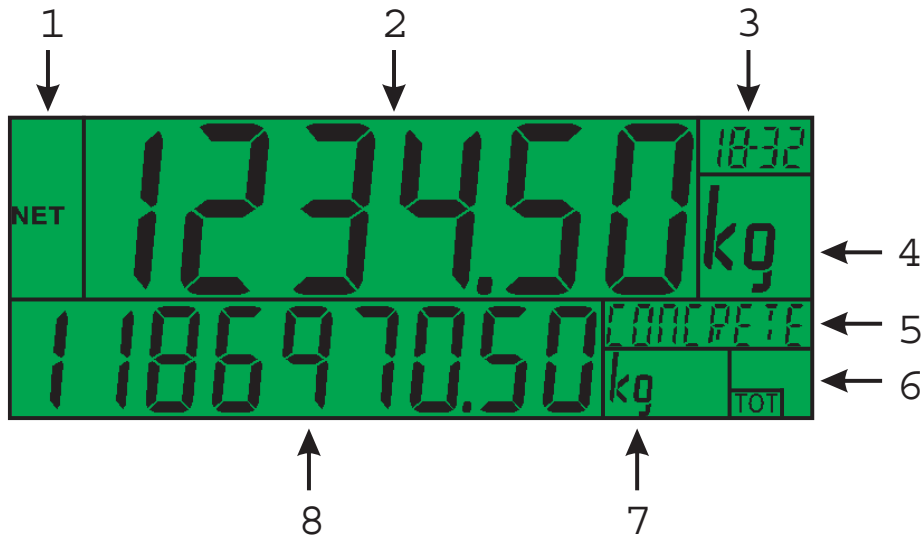

Code	Description	
1	Primary Annunciators	Table below
2	Primary Display	
3	Auxiliary Display	Configuration 14.1.4
4	Primary Units	
5	Secondary ID E.g. Product Name = CONCRETE in example above.	
6	Miscellaneous Annunciators	Table below
7	Secondary Units	
8	Secondary Display	Configuration 14.1.4

Primary Annunciators		
HOLD	HOLD	Visible when the displayed reading is held.
NET	NET	Visible when the displayed reading represents Net weight.
⇒0←	ZERO	Visible when the gross reading is within $\pm\frac{1}{4}$ of a division of true zero.
~	MOTION	Visible when the displayed reading is not stable.
┌┐	ZERO BAND	Visible when the displayed weight is within the zero 'dead' band setting.
← →	RANGE	Indicates current range (for dual range/interval).
Miscellaneous Annunciators		
 / - - \ 	Rotating	RUN - Batch running
 / - - \ 	Stationary and flashing	PAUSE - Batch paused
⌚	Lit	Time Delay - Time annunciator lit while a time delay is in progress at the start or end of a stage.
⌚	Flashing	WAIT - Time annunciator flashes when the instrument is waiting for an input during a PULSE stage.
▬ ▬ ▬		Bars indicate Slow, Medium, and Fast speed filling in progress

4.1.2. Keypad

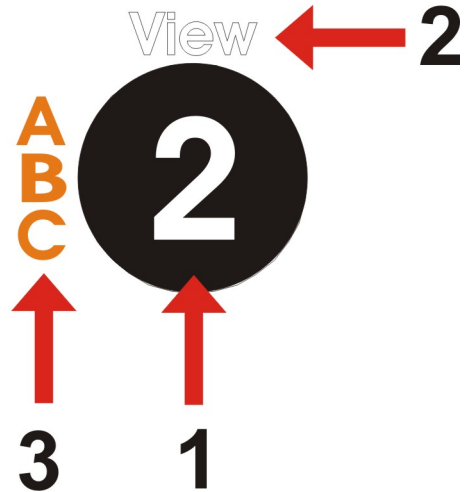

Code	Description		Reference Section
1	Numeric Button	0-9	
	Cancel	Undo last command; step backwards (including in setup menus).	
	Up	Move cursor backwards; previous option	
	Down	Move cursor forwards; next option	
	OK	Accept this choice	
	Decimal Point	Place decimal point	
	+/-	Change to negative or positive number; Change Editing VIEW (e.g. ASCII vs string)	
2	White Commands	Hold 2 seconds	4.8
3	Orange Characters	Alpha and Symbols are made available in certain menu items to enter a string or data	5.4

Legend:

- Press Single beep
- Press and hold Double beep
- Display flashing

4.2. Power – On/Off

On Instrument - Short press <Power>

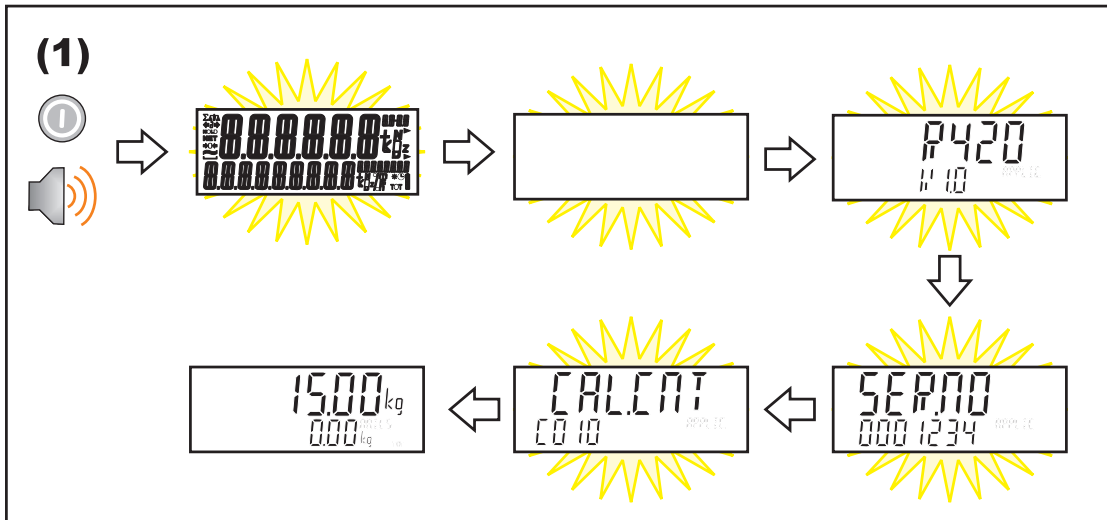

OFF Instrument - Long press <Power>

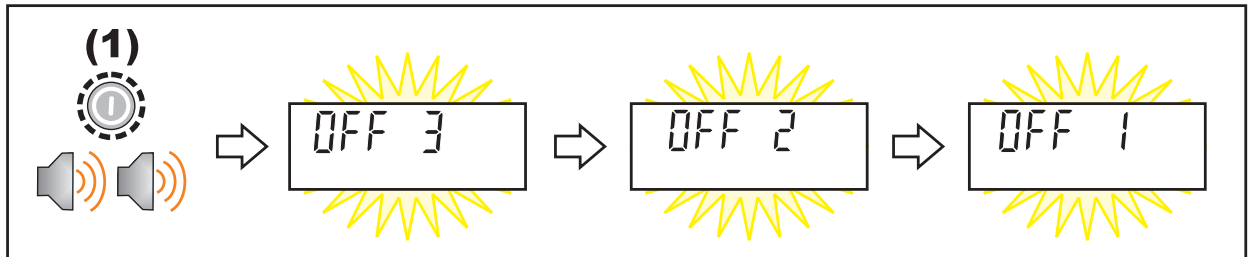

4.2.1. Additional Information

Power Key Locked: If the power key is locked, the instrument cannot be turned off from the front keypad.

Automatic Operation: Instrument will operate whenever external power is available and will not need to be manually turned on again if the power is interrupted.

4.3. Stability Considerations

Some functions (e.g. Tare and Zero) require a stable weight. These functions will wait for up to 10 seconds for stable weight. If a stable weight is not available 'MOTION ERROR' is displayed and the function is cancelled.

4.4. Zero

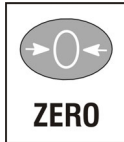

When an empty scale has drifted away from a true zero reading, this key is used to perform a zero adjustment on the scale display. The zero adjustment is stored when power is removed and is re-used when next powered up.

The amount of weight that may be cancelled by the <ZERO> key is limited by the Z.BAND setting (14.3.2 OPTION (Scale options), p94). Note automatic batching options may override <ZERO> or <TARE>.

Short Press

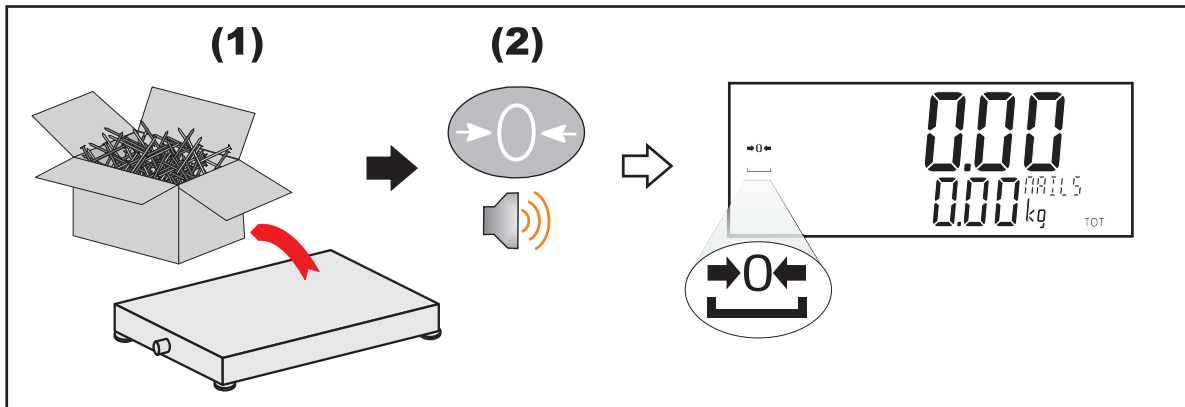

4.5. Tare



This key is used to temporarily set the scale to zero (such as cancelling the weight of a carton before performing a filling operation). The display will show the Net weight and the NET annunciator will be lit.

The weight tared is deducted from the allowable range of the scale, reducing the maximum weight that can be displayed. Note: automatic batching options may override <ZERO> or <TARE>.

Short Press

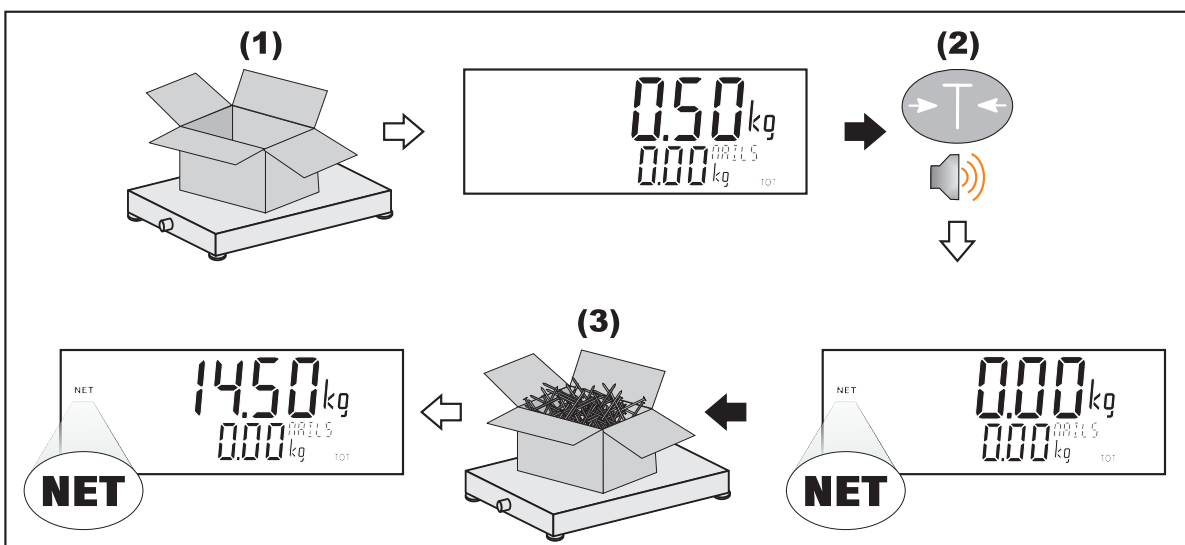

4.6. Recipe

<RECIPE> is used to enter product recipe details. The following recipe details are shown for operator entry (accessed using the up and down arrows) if they have been nominated in the batching setup:

- Target: For each fill stage there is a prompt for the target weight.
- Number of Batches: Prompt for the number of batches to run (option only appears when auto start (BATCH:GEN:AUTO.ST) = NUM in the setup menu).
- Proportion: The proportion of the batch to make, either as a percentage, ration or weight (option only appears when a type of proportional control (BATCH:GEN:PROP.TP) is selected in the setup menu).
- Preset Tare: Value of the preset tare stored for this particular product if being used (option only appears if BATCH:GEN:USE.PT = YES in the setup menu).
- Start, Repeat and End time: The start, repeat and end times for timer based multiple batching (options only appear when auto start (BATCH:GEN:AUTO) = TIME in the setup menu).

Exit recipe setup using either the <OK> or Clear <C> buttons. Refer page 73 for further discussion.

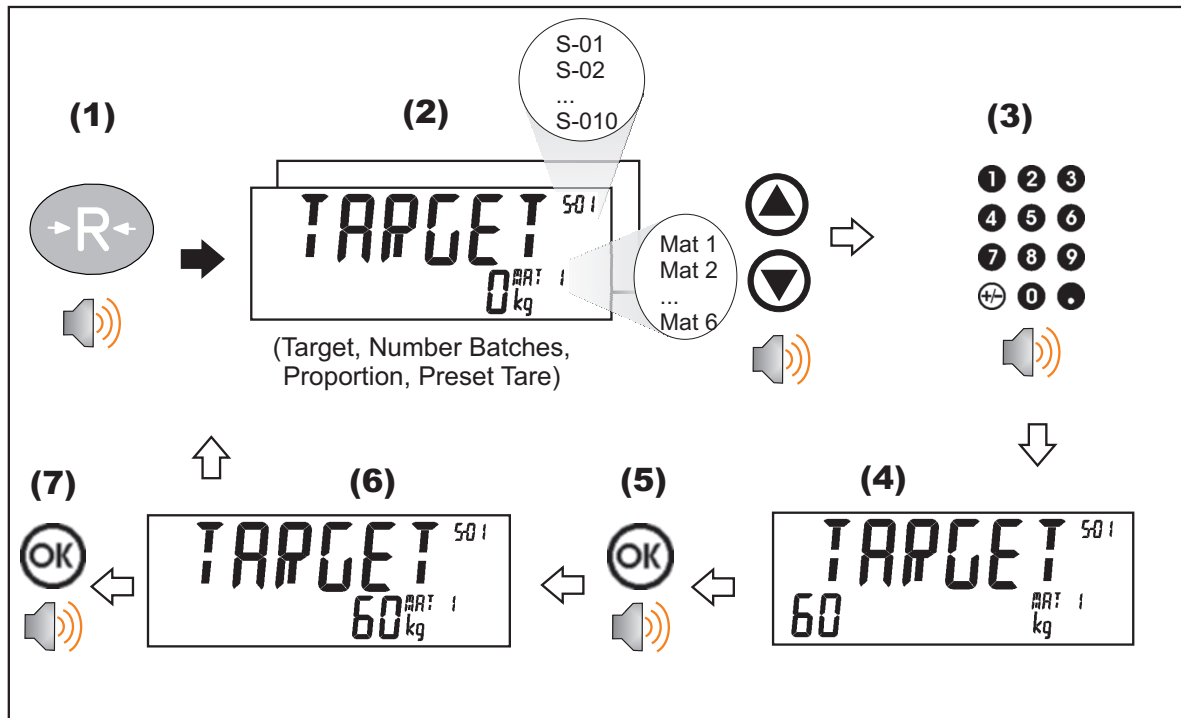

4.7. Special Functions - Function Keys and External Inputs

The instrument supports up to eight (8) special functions that can be configured as: print, single, test, rem.key, blank, thumb, start, pause, abort, pse.abt, and st.ps.ab.

The special functions can be allocated to:

- the three (3) unassigned **<FUNCTION>** keys (f1...f3) on the front panel; or
- the external inputs/outputs (IO1...32).

Refer to 14.4 FUNC (Special functions) page 96 for the setup menu where the number of special functions is set then each is configured to a function type and allocated to a key or input. Most functions need only to be associated with a key or input, but some have additional configuration settings. When set to **NONE** (default) the special function key is not used during normal operation.



<FUNCTION> keys have no primary function pre-programmed. Each primary function has an associated overlay sticker (supplied) to be applied to the function key to label the function. Ensure the keypad is clean and dry before affixing the sticker.



4.7.1. PRINT

A print key will initiate a printout on the serial port. Only RECORD type printouts can be used. For setup, see section 10.3 Record printouts page 60.

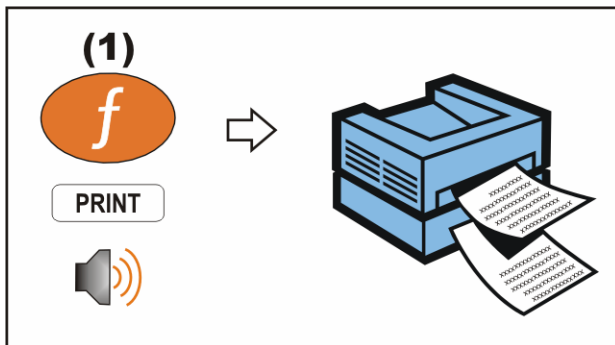

4.7.2. BLANK (Blanking Input)

When a blanking input is active the instrument screen is either blanked or dashed out and all keys are blocked.

4.7.3. SINGLE

A Single key is used to initiate a single transmission on the serial port.

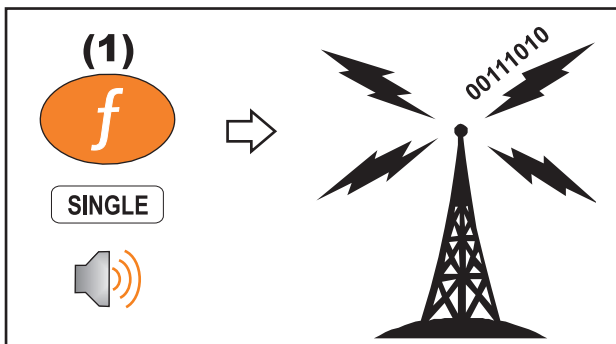

4.7.4. TEST

A Test key performs an all segment test.

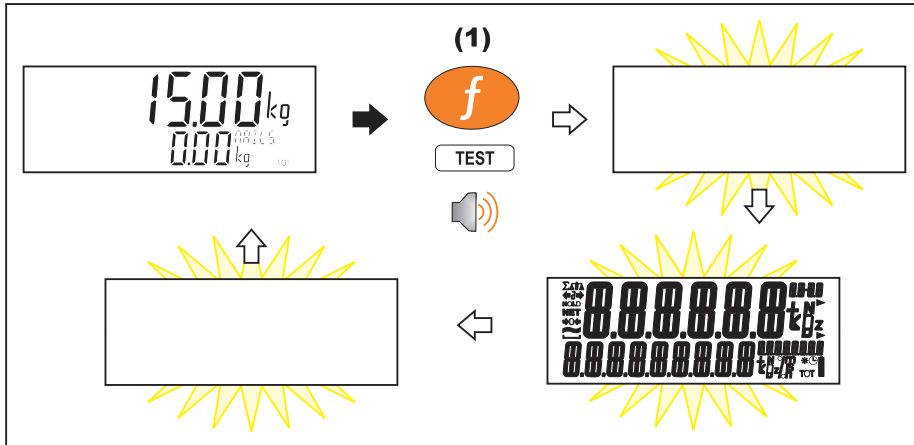

4.7.5. START

The START key will start a batch or resume a batch if it has been paused. If the recipe check option is set (BATCH:GEN:REC.CHK) the START key will not work until the recipe is first confirmed. Batching is discussed further in 13 Batching page 73.

4.7.6. PAUSE, ABORT, PSE.ABT, ST.PS.AB, SUSPND

A PAUSE key is used to pause batching and the START to resume batching. An ABORT key is used to halt the batch.

A pause/abort (PSE.ABT) key combines the two functions using a short and long press of the key: short key press to pause and a long key press to abort the batch. To resume batching from pause, press the START key.

A start/pause/abort (ST.PS. AB) key combines the three functions. A short press toggles between start and pause, and a long key press aborts the batch.

A suspend (SUSPND) pauses the batch and will adjust the tare weight (if in NET mode) when resuming the batch (with the START key). This is useful if the material needs to be topped up during the batch without affecting the batched amount.

Batching is discussed further in 13 Batching page 73.

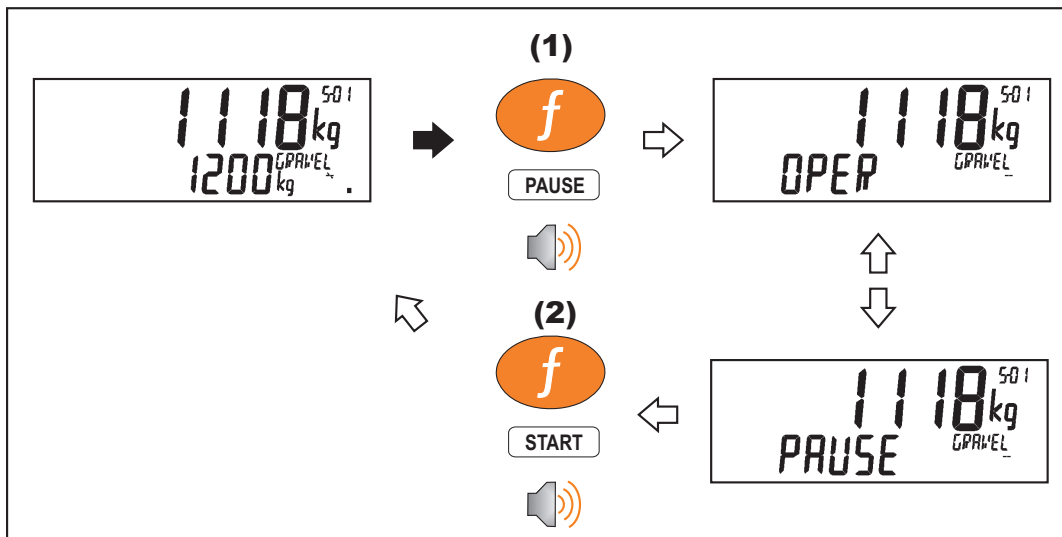

4.8. Numeric Keypad – White Commands

The white commands on the numeric keypad are accessed via a long press (2 seconds) of the key. They include: clock, view, report, total, ID, timers, target, tolerance, lock, alibi, and accessory. These functions are typically used by the operator, but their availability can be set through keylock, refer to 5.2 Passcodes page 40.

4.8.1. System Time and Date (Clock - 1 key)

A long press of the 1 key (Clock) allows the system time and date to be viewed and changed. The date format is defined in the setup menus, refer 14.1.1 DATE.F (Date format) page 85.

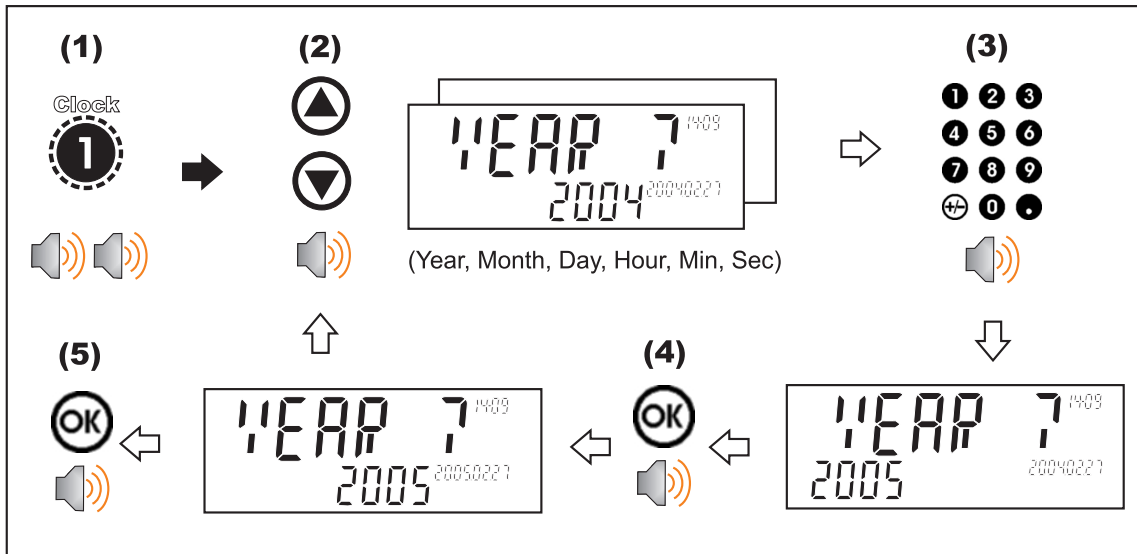

4.8.2. Display View (View - 2 key)

A long press of the 2 key (View) allows what is being displayed in the Primary and Secondary displays to be changed. The default view is defined in the setup menus, as discussed in 14.1.4 DISP (Display options) page 87, and is used at start up.

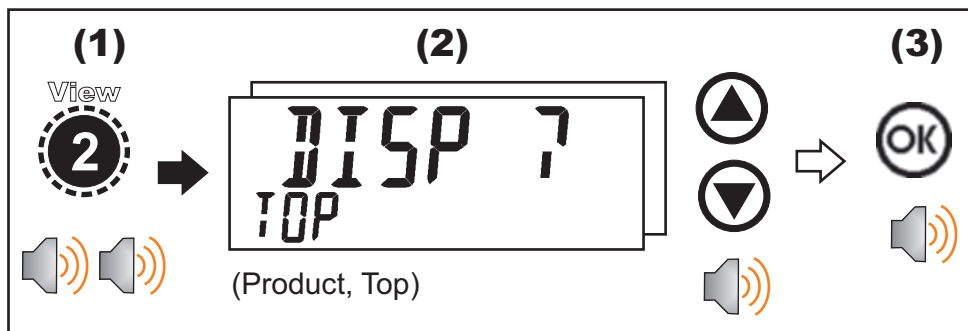

4.8.3. Reports (Report - 3 key)

A long press of the 3 key (Report) will allow the operator to choose a report to print. The operator will have the option to clear totals after printing. The setup of printouts is discussed in Report printouts page 63.

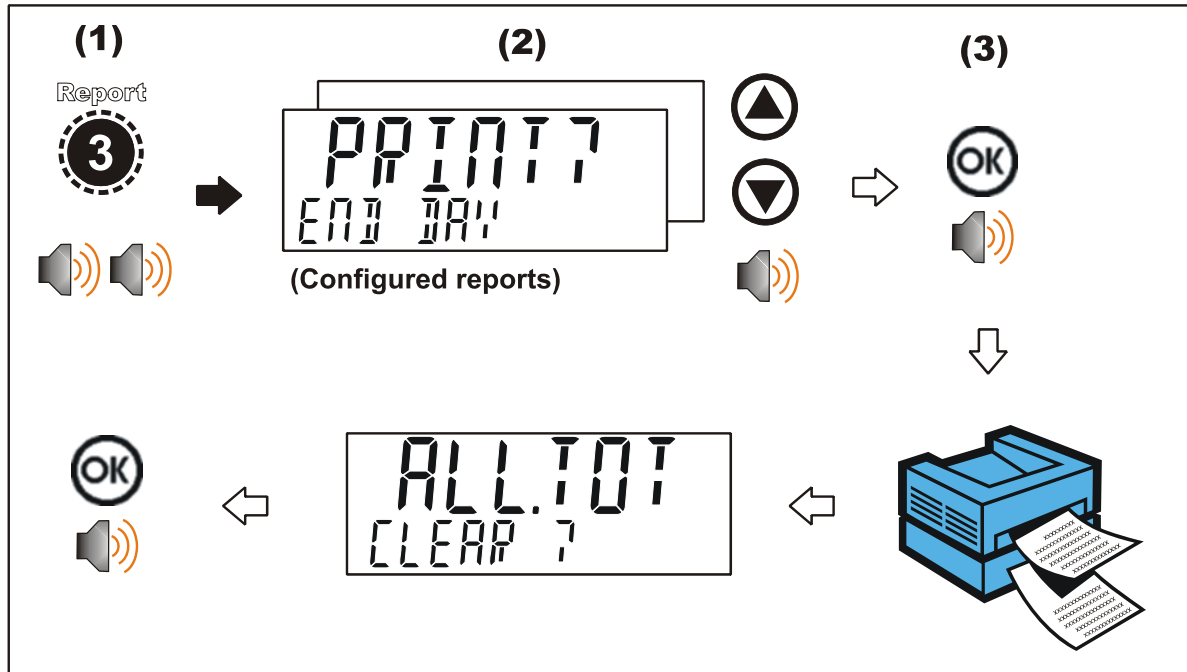

4.8.4. View and Clear Totals (Total - 4 key)

A long press of the 4 key (Total) will display the totals data and allow the operator to clear totals. Data is accumulated since totals were last cleared. The following data is available:

- Material Totals. For each material:
 - Total material used
 - Number of fill operations
 - Amount of over/under usage (compared to fill targets)
- Grand Total and Product totals (currently selected product/recipe)
 - Total product batched
 - Number of batches
 - Average time per batch
 - Average batch error

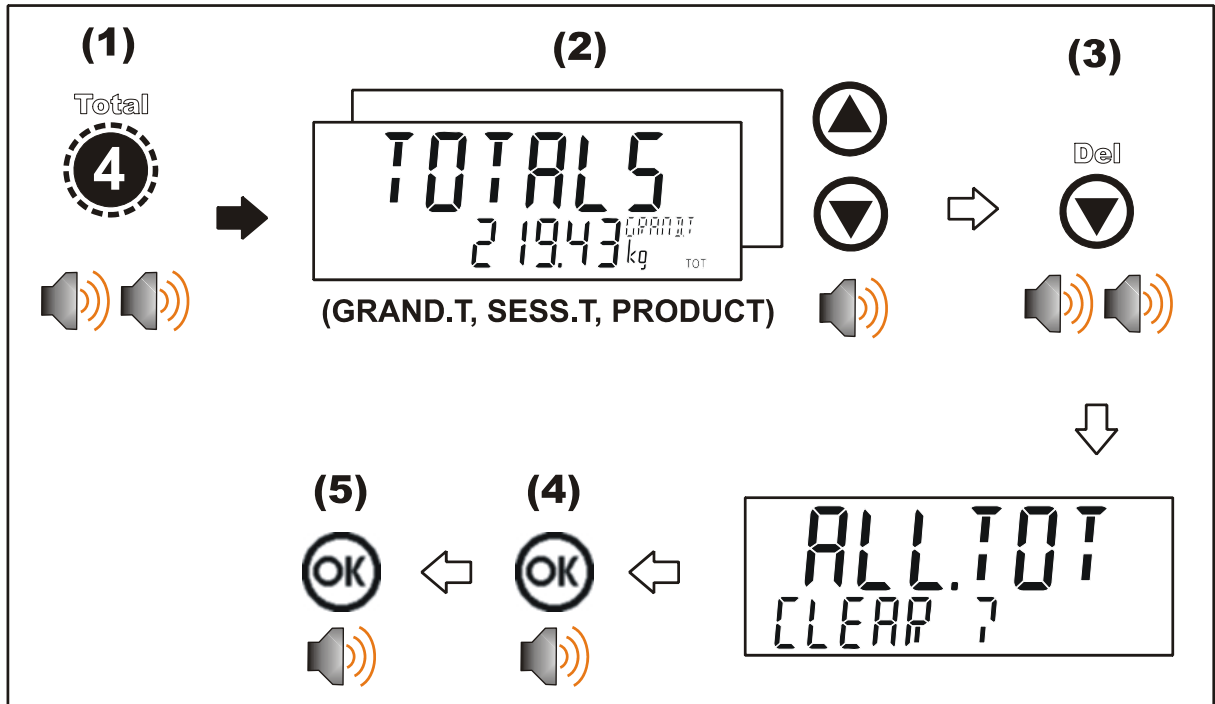

4.8.5. View and Clear ID Names (ID – 5 key)

A long press of the 5 key (ID) allows IDs names to be viewed and cleared. The string in the Primary Display (e.g. CUST) is defined in the setup menu. The string in the Secondary Display (e.g. AA MINES to BB CLEAN) is set by the operator. Refer to 14.1.5 ID.NAME (ID name strings) page 87. The Settable Consecutive Print ID can also be viewer and edited. The product barcode field is also able to be viewed and edited.

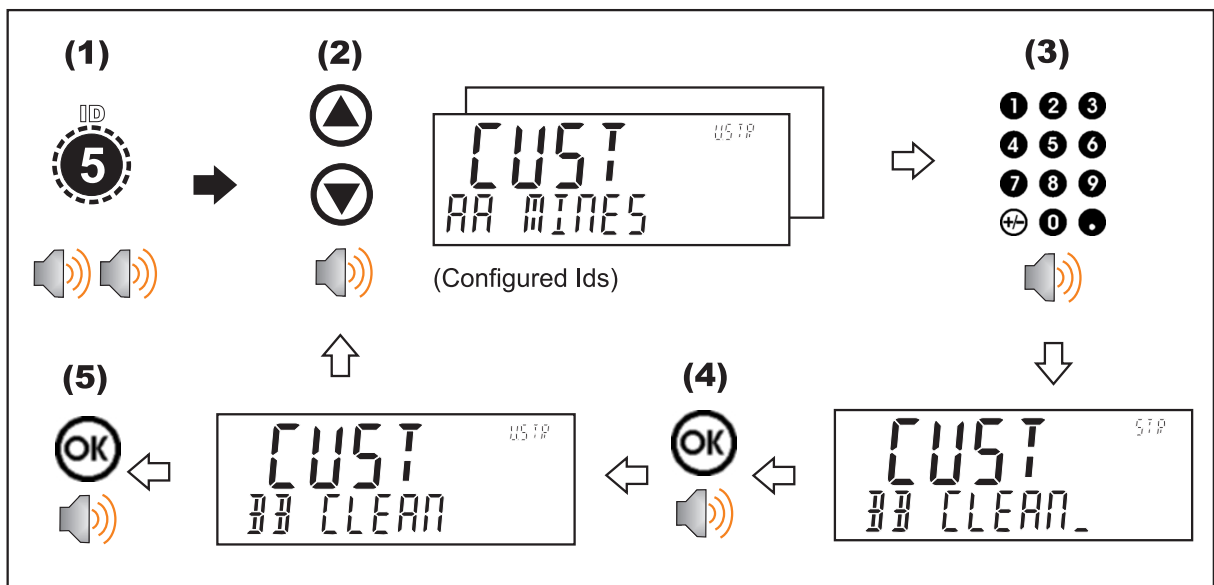

4.8.6. View and Change Pulse Timers (Timers - 6 key)

A long press of the 6 key (Timers) will give access to the pulse times for any PULSE stages.

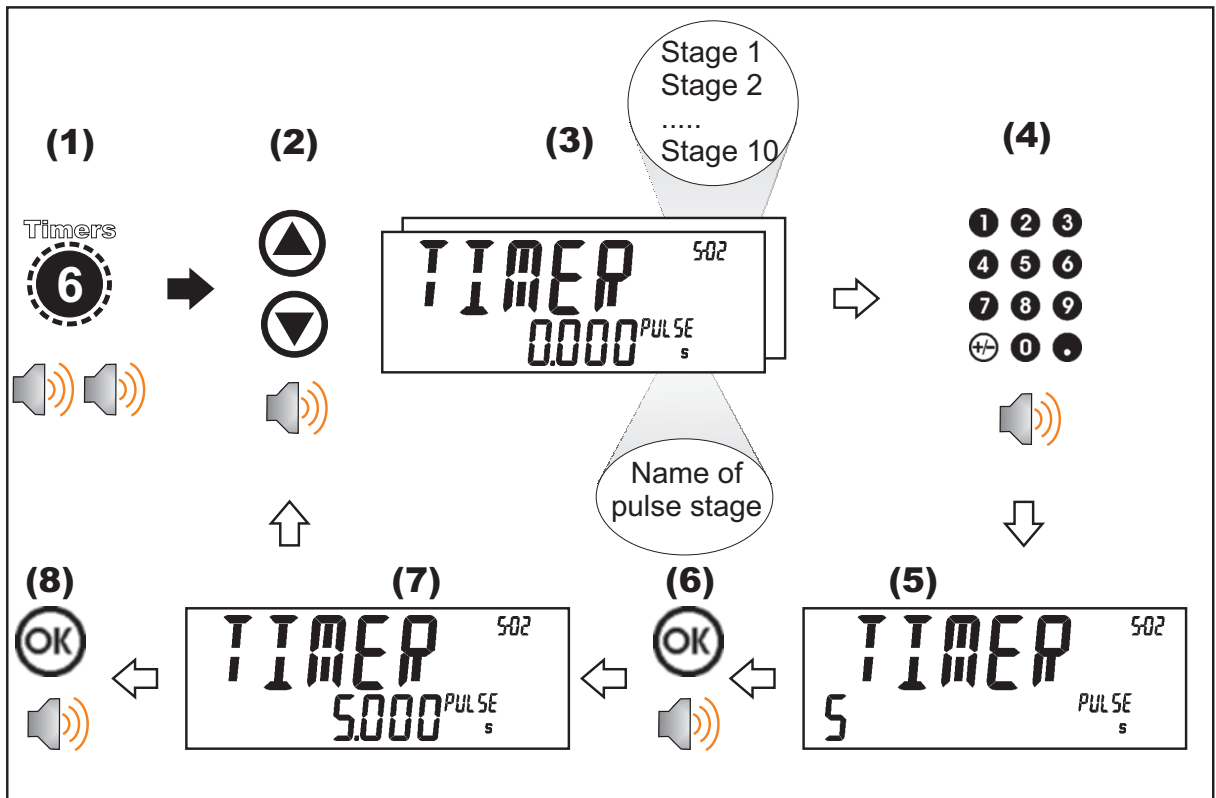

4.8.7. View and Change Setpoint Targets (Target - 7 key)

A long press of the 7 key (Target) allows setpoint targets to be viewed and changed. Refer to 14.8 SETP (Setpoints) page 105 for menu setup and 11 Setpoints page 65 for further discussion.

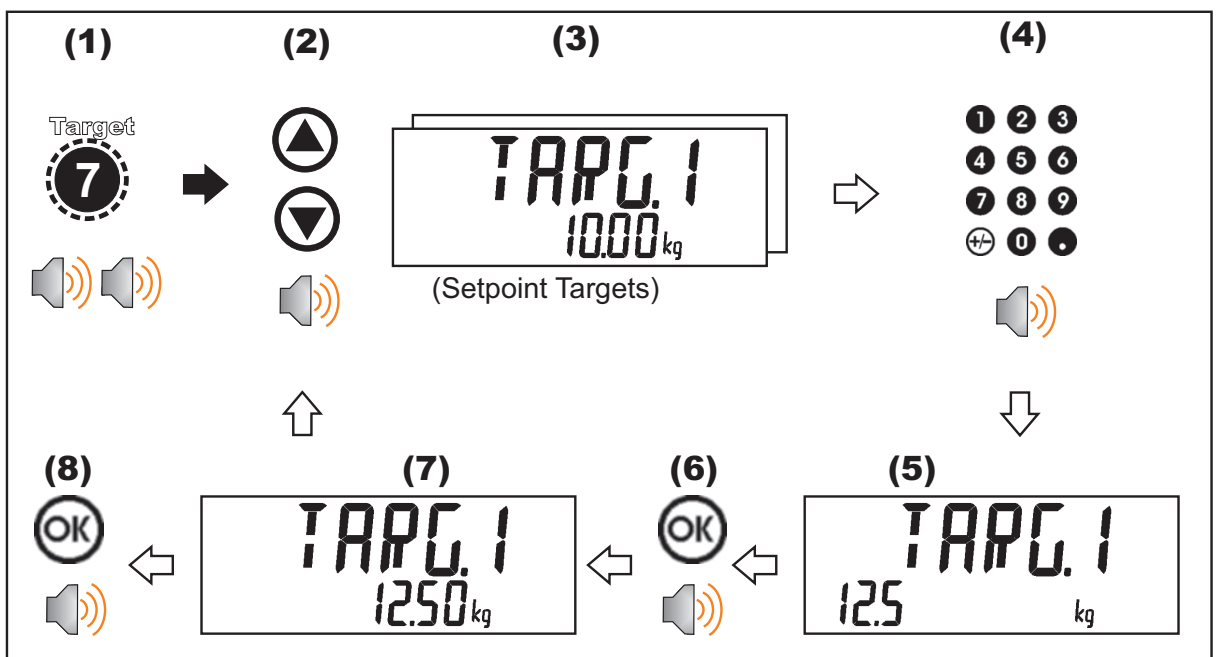

4.8.8. Flight Settings (Flight – 8 key)

A long press of the 8 key (FLIGHT) will give access to FLIGHT settings for each material, at each fill speed:

- In-Flight (FLIGHT): For single speed only
- Medium Fill Prelim (M.PRE): For dual and triple speed only
- Fast Fill Prelim (F.PRE): For triple speed only

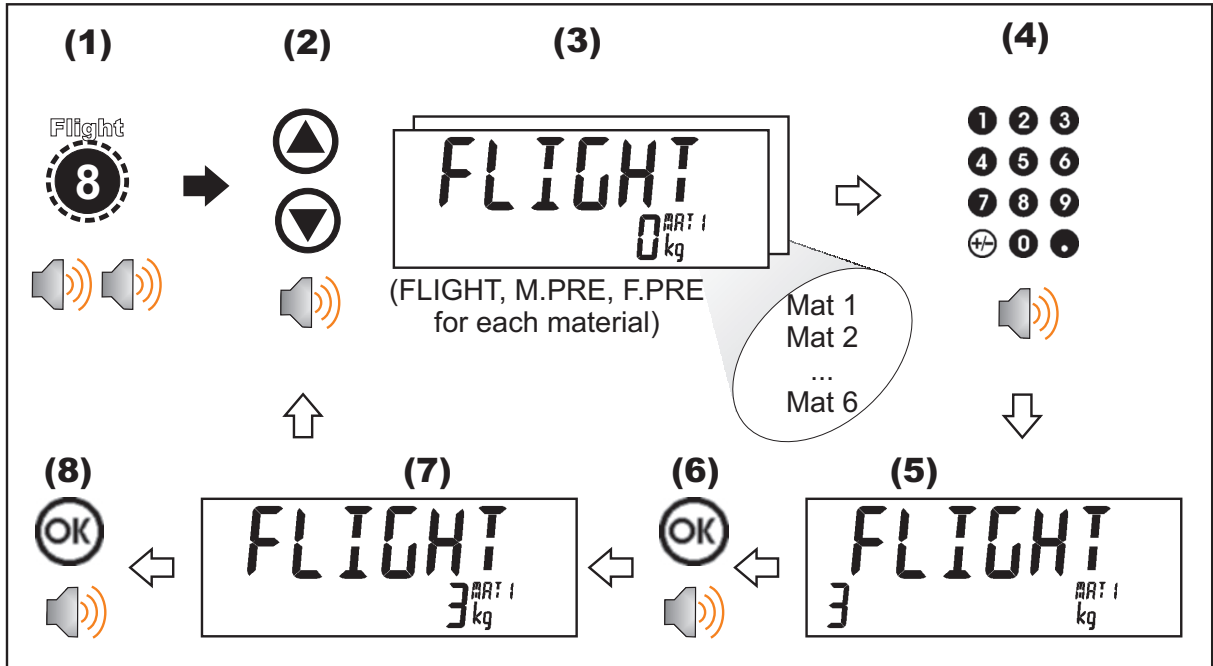

Refer also to 13.8.4 FILL Correction (Jogging and In-flight) page 81 and 14.9.5 STAGE.n:FILL page 112 for further discussion on batching.

4.8.9. Tolerance (TOL - 9 key)

A long press of the 9 key (TOL) gives access to the high and low tolerances (incremental above and below target) for each FILL stage. Using up and down arrows to scroll through high and low tolerance for each stage, entering the amount and using OK to confirm entry.

- High Tolerance (TOL.HI)
- Low Tolerance (TOL.LO)

Refer also to 13.4.4 Tolerance (9 key) – high and low tolerance for each fill stage page 78 and 14.9.2GEN (General) page 109.

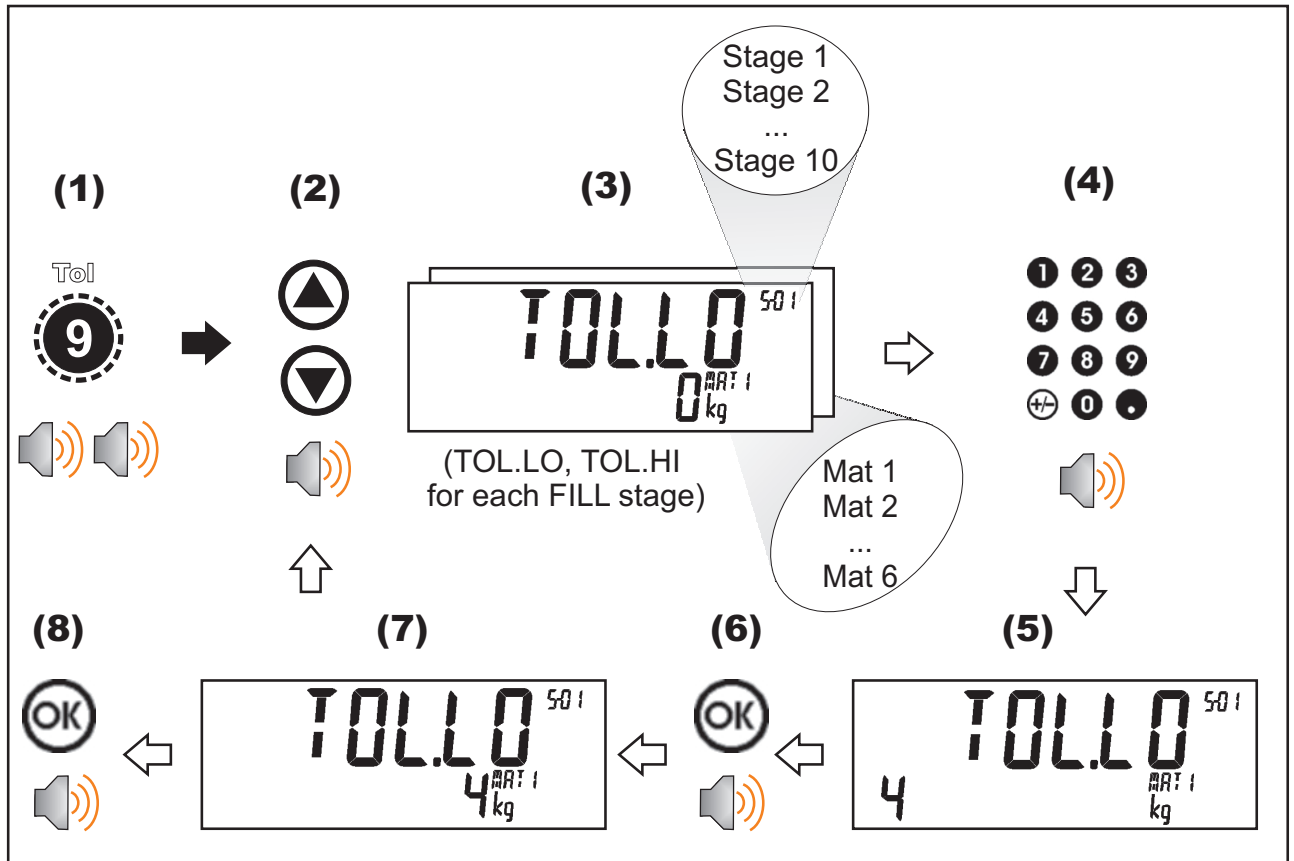

4.8.10. Keypad Lock (Lock - . key)

A long press of the '.' key (Lock) locks the instrument. The instrument can be unlocked by entering the operator passcode when prompted. Refer also to Passcodes page 40 for setup.

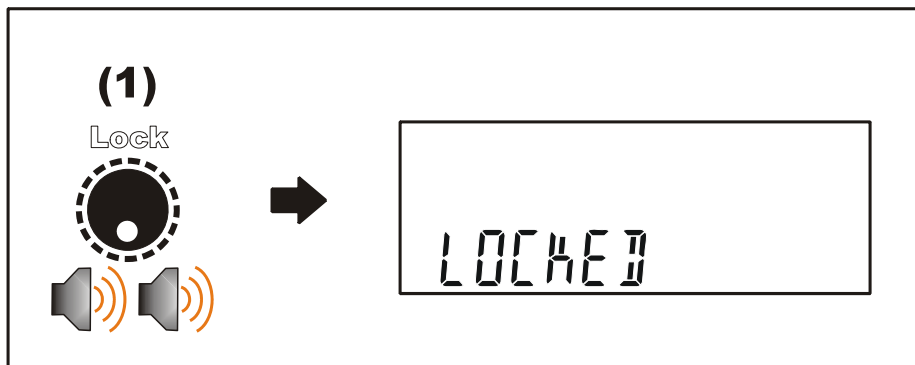

4.8.11. Alibi (+/- key)

A long press of the +/- key (Alibi) will switch the instrument to Alibi mode. Alibi mode is used to verify scale readings. To return from Alibi mode, long press the +/- key (Alibi) again.

◆ **Switching to Alibi Mode**

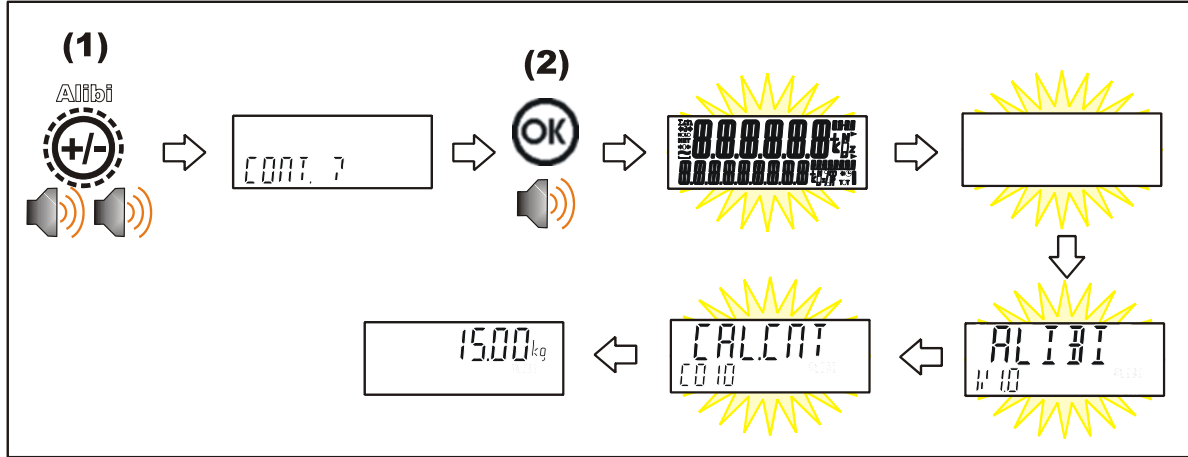

◆ **Returning from Alibi Mode**

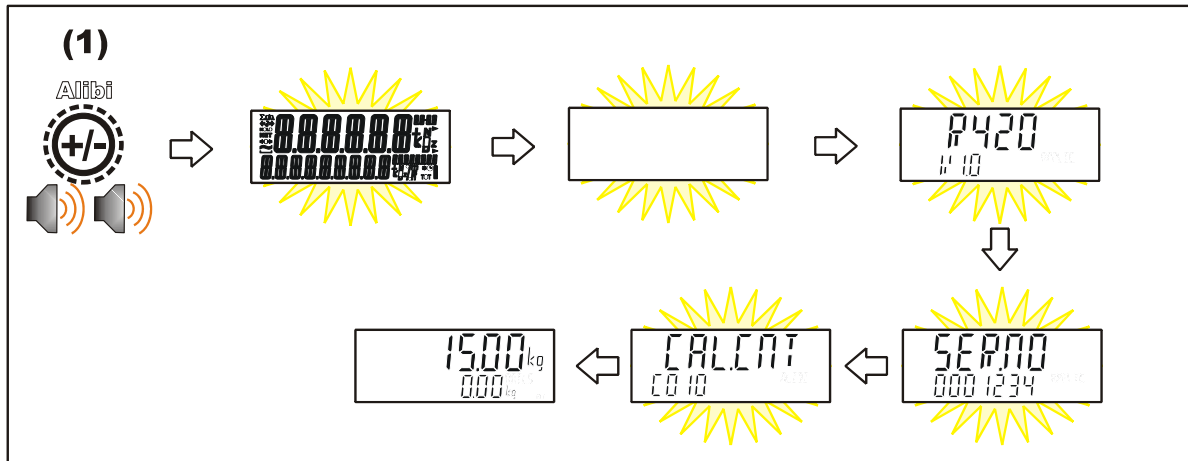

◆ **Viewing DSD records in Alibi mode**

From Alibi mode you can view DSD records (when a DSD is fitted) by pressing the up-arrow key to view the latest record, pressing the down arrow key to view the oldest record or by entering a number than pressing the OK key to view that specific record. When viewing records, you can use the +/- key to display the different information stored in the record, use the up-arrow key to move onto the next record or use the down arrow key to move onto the previous record. Once you are finished viewing records, you can return to Alibi mode by pressing the C key.

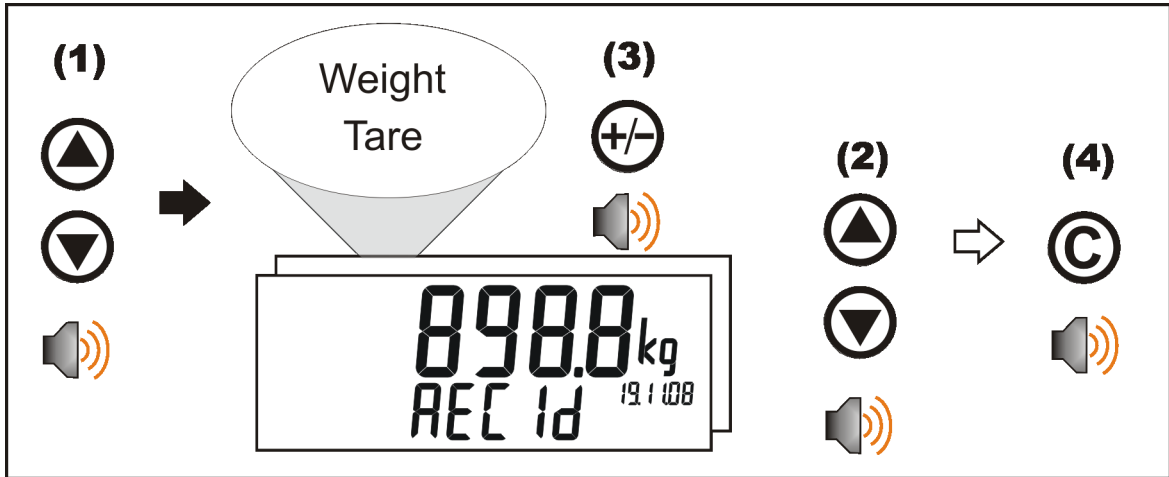

4.8.12. Accessory Modules (Acc – 0 key)

A long press of the 0 key (Acc) is used to view information about the attached accessory modules. The slot information is displayed as SL-1, SL-4, SL-5, and SL-6 in the Auxillary display (up and down arrow to change). The description of the module covers:

- TYPE – Type of module.
- SER.NO – Serial Number of the module.
- SW.VER – Software Version of the module.
- STATUS – Condition (working or otherwise) of module.

Refer to 3.13 Accessory Module connection page 17 for additional discussion.

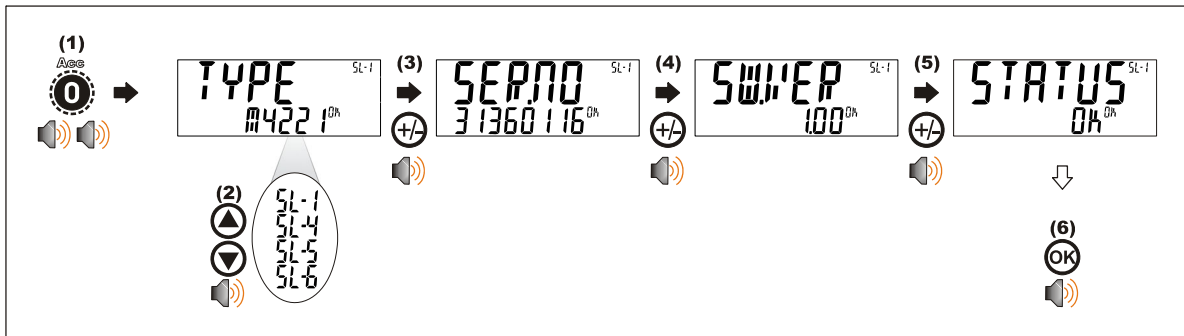

When an M4221 Ethernet module is attached, the current IP (Internet Protocol) settings can be viewed from the Acc menu. The “.” key allows the second half of longer IP addresses to be displayed. In this example the DNS 2 IP address is 192.168.100.10.

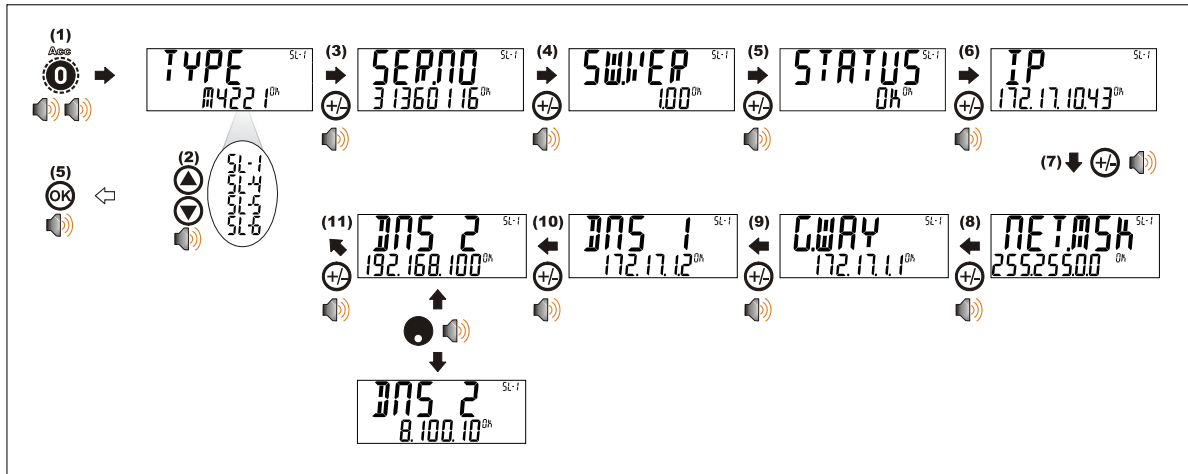

4.8.13. Up, Down, OK keys: Products

These keys are used to control the products. A short press of <UP> and <DOWN> keys is used to select products. A long press of the <UP> key will add new products. A long press of the <DOWN> key will delete products. A long press of the <OK> key will edit the name of the current product.

◆ Short Press of Up and Down keys

A short press of these keys will allow the user to select the desired product from a list of the most recently used. The keypad can be used to enter the first letter of the product name. The <UP> and <DOWN> keys will then step through the list of products starting with the entered letter.

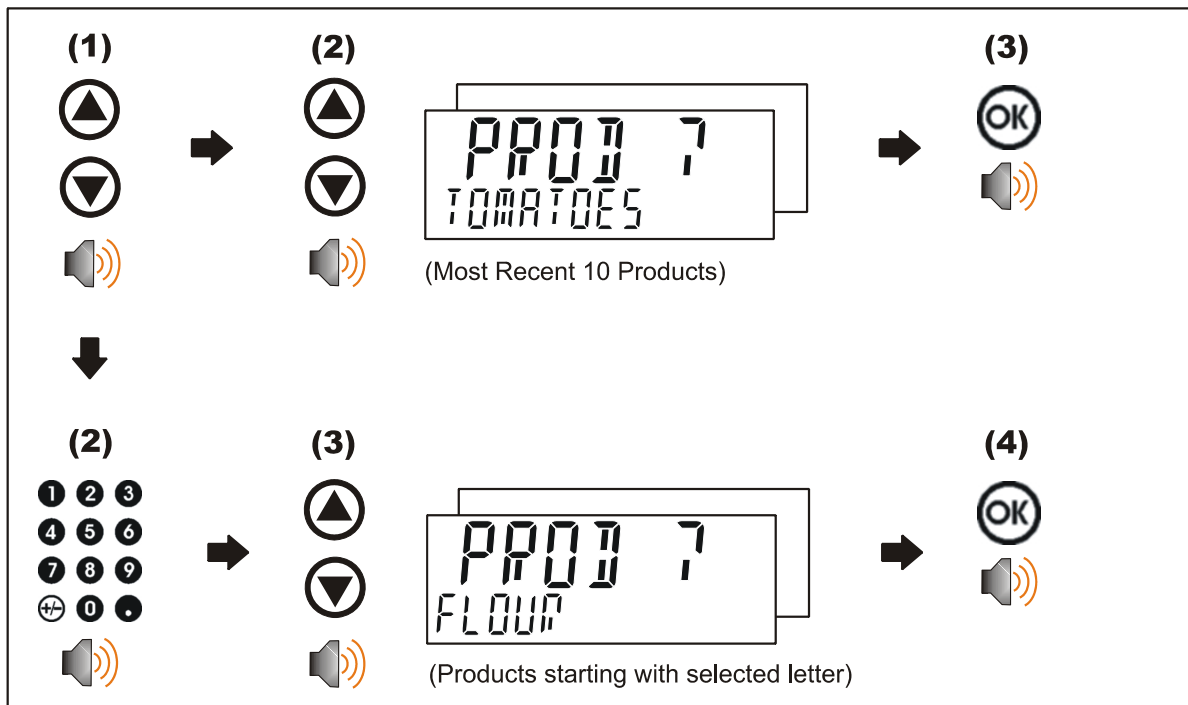

◆ Long Press of the Up Key (Add)

A long press of this key allows the user to create a new product. The name of the new product must be specified. In K412 the materials to be used for the product must also be selected.

K410 and K411:

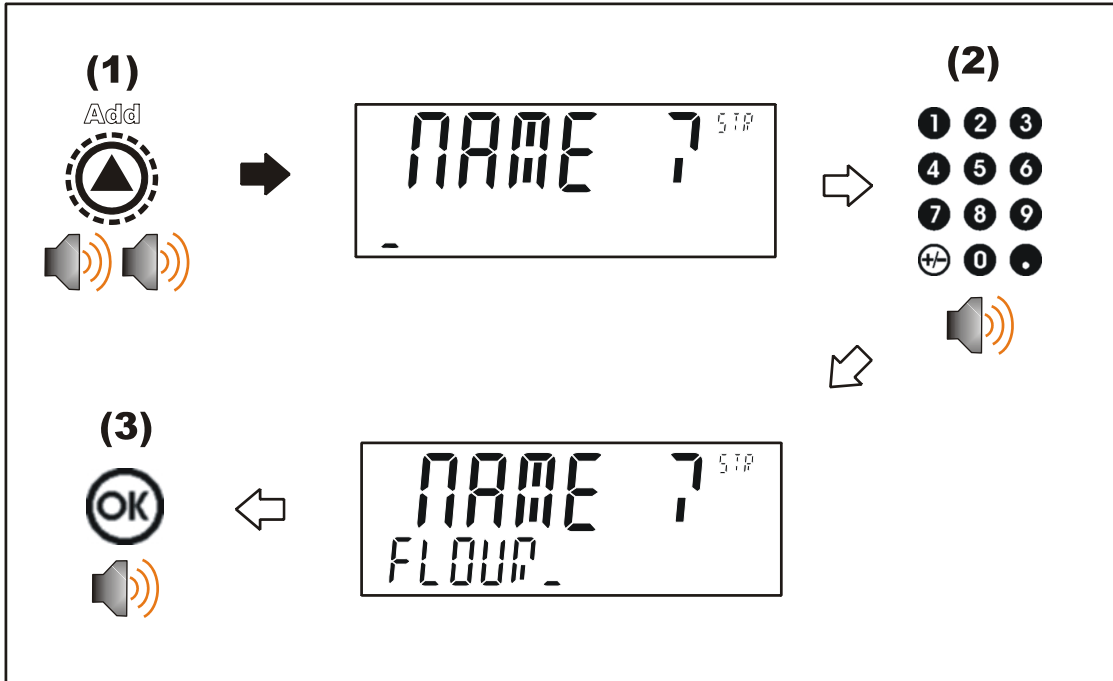

K412:

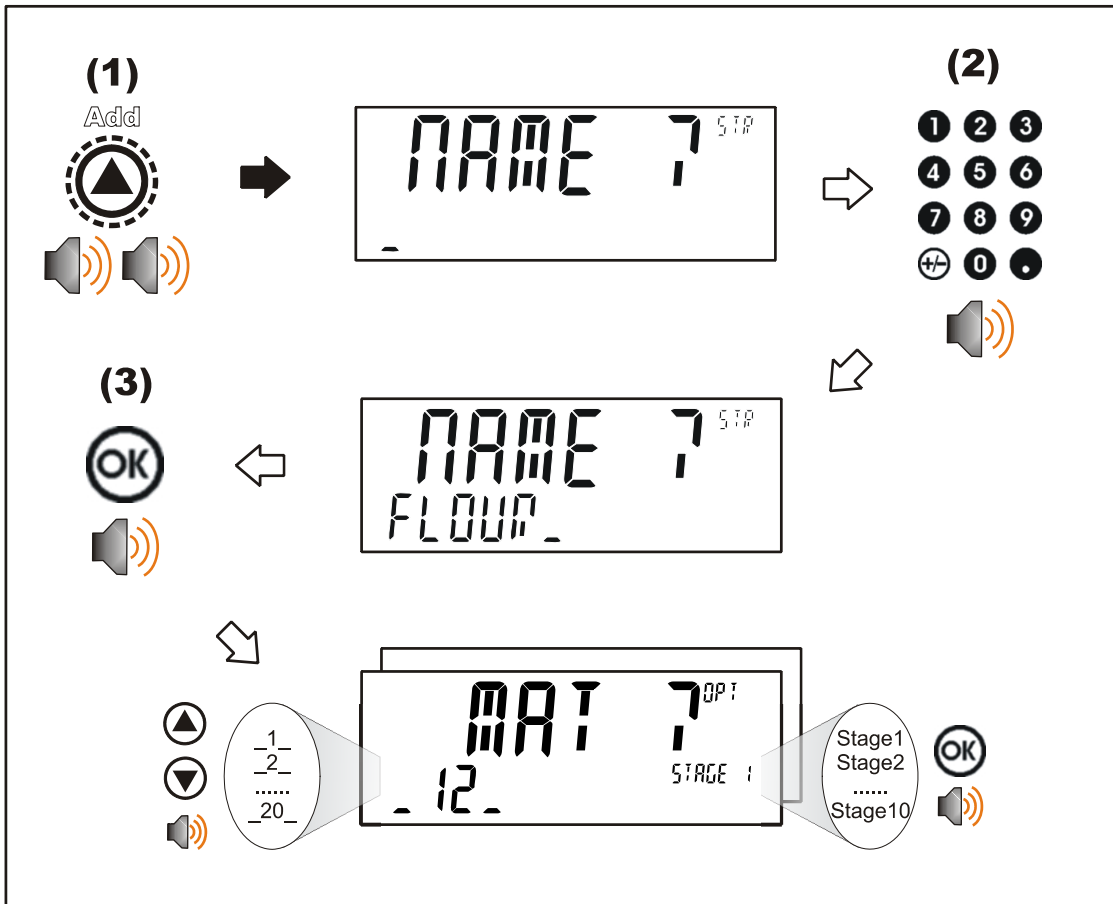

◆ **Long Press of the Down Key (Del)**

A long press of this key allows the user to delete the current product. Products can only be deleted if the total weight is 0. Product totals can be cleared using a long press of the 4 key (Total).



◆ Long Press of the OK Key (Edit)

A long press of this key allows the user to change the name of a product. In K412, this also allows you to change the materials to be used for the product.

K410 and K411:

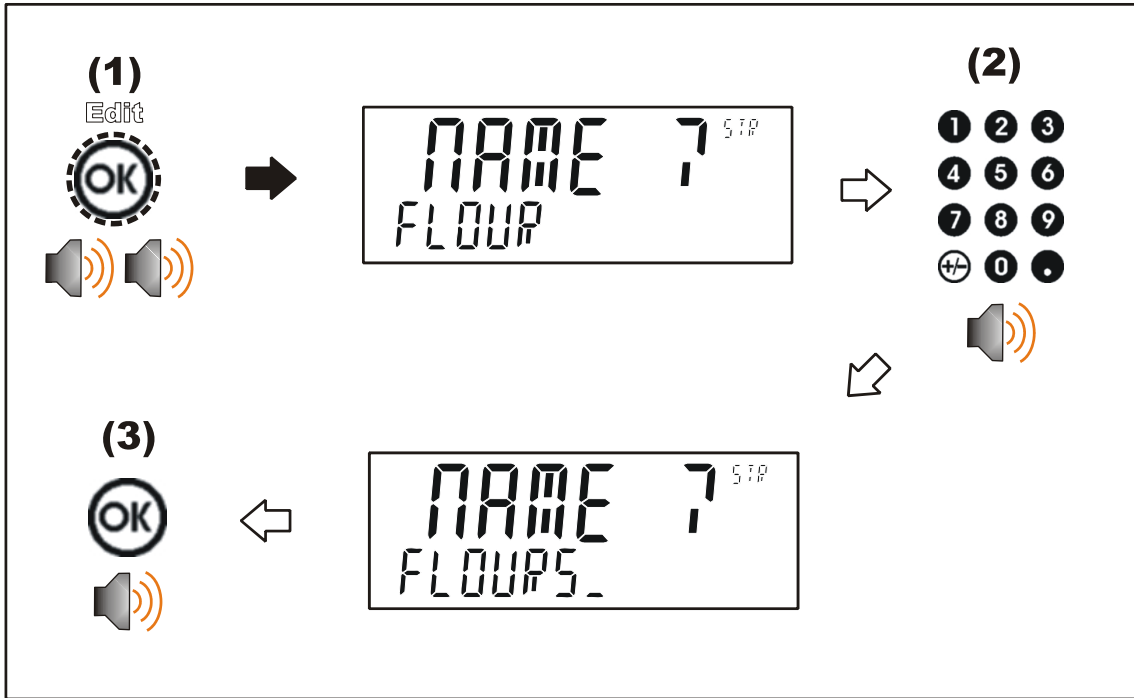

K412:

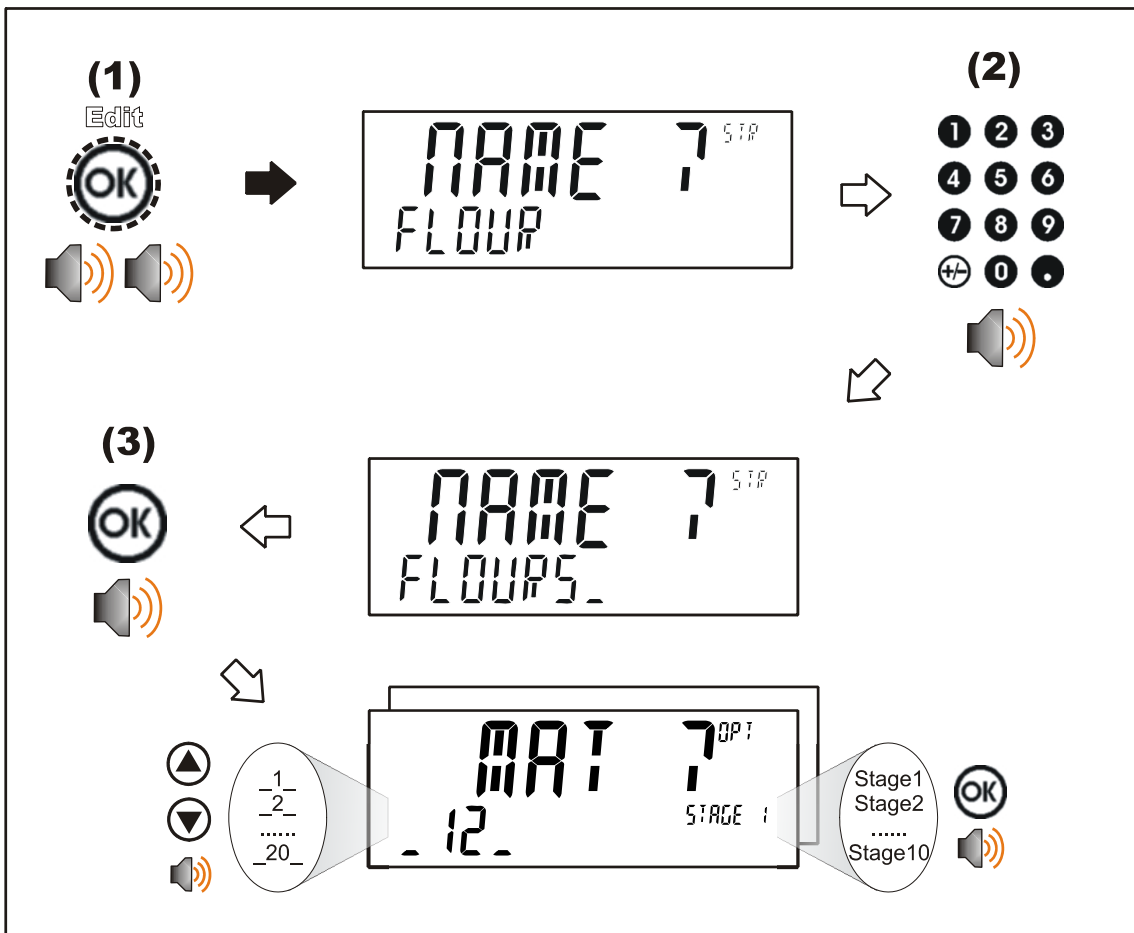

5. Instrument Configuration

5.1. Accessing Full/Safe Setup

Configuration and calibration can be performed entirely from the front panel, using the digital setup facility. When **Full Setup** is used, all menu items are accessible, and care must be taken to ensure no accidental changes are made to calibration and trade settings. **Safe Setup** allows access to only non-trade critical settings. Full and Safe Setup can be passcode protected to prevent unauthorised or accidental tampering.

5.1.1. Full Setup

The **Full Setup** method provides access to all functions in Setup, including legal for trade and calibration sensitive settings. Changes in Full Setup mode may result in the calibration counter being incremented. If an attempt is made to enter Full Setup using the incorrect passcode, the instrument will respond with the message **ENTRY DENIED**. Refer to Passcodes page 40 for more information.

Full Setup	
	<p>To access Full Setup, first ensure the instrument is on. Then press and hold both the <POWER> and <F3> keys together for two seconds.</p>

WARNING

All items in all menus will be enabled in **Full Setup**. Care should be taken to avoid inadvertently altering the Build or Calibration settings.

5.1.2. Safe Setup

The **Safe Setup** method restricts access to the Trade Critical settings. Changes made in this mode will not increment the calibration counter. In this manual, items marked with ⊗ indicate that the setting is trade critical. If an attempt is made to enter Safe Setup using the incorrect passcode, or if an attempt is made to alter a trade critical setting while in Safe Setup, the instrument will respond with the message **ENTRY DENIED**. Refer to Passcodes page 40 for more information.

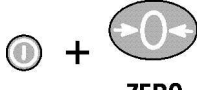
Safe Setup	
 <p style="text-align: center;">ZERO</p>	<p>To access Safe Setup, first ensure the instrument is on. Then press and hold both the <POWER> and <ZERO> keys together for two seconds.</p>

5.1.3. Setup Display Prompts

When accessing **Full** or **Safe Setup** the instrument will beep twice and enter the Setup Menu. If a passcode has been configured, the **P.CODE** prompt will display and the correct passcode must be entered to continue (refer to Passcodes page 40). If access is granted, the following is displayed:

FULL (SAFE) → SETUP → Software Version (e.g. V1.0) → Serial Number
→ Calibration Counter (e.g. C.00010).

5.1.4. Exiting Full or Safe Setup

To save settings, exit setup and return to the normal weighing mode using one of the following methods:

Method 1: Press the <POWER> key.

Method 2: Press the <ZERO> key repeatedly. When End displays press <TARE>.
--

The instrument will beep and then display the following:

Software Version (e.g. V1.0) → Calibration Counter (e.g. C.00010).

If the power is interrupted while in setup (i.e. by disconnecting the power cable), unsaved settings will be lost.
--

5.2. Passcodes and Key Lock

The instrument has three levels of passcode (FULL.PC, SAFE.PC, OP.PC) to provide security for instrument functions, calibration and general configuration. Access to operator functions can set function by function and according to passcode level. Instrument settings that are accessed by the communications are protected by the same passcodes. For setup menu structure refer to 14.1.2 PCODE (Security passcodes) page 85 and KEY.LOC (Key Function Access Control) page 86.

5.2.1. Full Setup Passcode

Setting a passcode for Full Setup then requires that a passcode be entered to access Full Setup. The Full Setup passcode can also be used to access Safe Setup and Operator functions.

5.2.2. Safe Setup Passcode

Setting a passcode for Safe Setup restricts access to Safe Setup functions. In addition, front panel functions can be configured to prompt for a Safe Setup passcode before operating. For the setup menu structure, refer to KEY.LOC (Key Function Access Control) on page 86 for more information.

5.2.3. Operator Passcode

The operator passcode is used to protect access to individual functions on the front panel. A long press of the '.' key will lock the front panel functions as defined in the setup menu. The operator will then be prompted to enter the Operator Passcode if a function that is locked is attempted to be used. Once entered, the operator will gain access to multiple functions (i.e. the passcode doesn't have to be entered to gain access to each function individually). A long press of the '.' key will lock the instrument again. Refer to KEY.LOC (Key Function Access Control) on page 86 for more information on how to add security to operator functions.

5.2.4. Setup Lock-Out

If an attempt is made to enter Full or Safe Setup using an incorrect passcode, the instrument will respond with the message **ENTRY DENIED** and then the user will be returned to normal operating mode.

No more than three failed attempts can be made to access Full/Safe Setup before the instrument blocks access completely. The instrument must be turned off and on again before further attempts can be made.

5.3. Menu Navigation

The setup menus are a normal menu tree structure. The six (6) function keys correspond to the possible six (6) menu levels with <ZERO> for Level 1 through to <F3> for Level 6. Generally, only up to four (4) levels are used. To access a lower level menu, use the function key to the right of the function key currently in use. To return to the upper levels, use the key to the left of your current key.

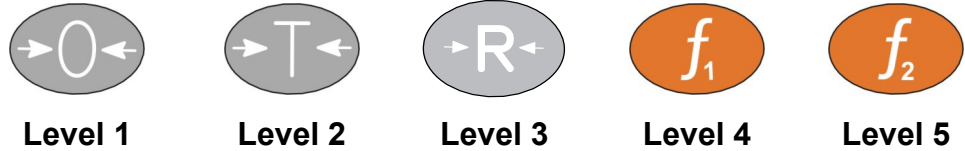

Example: GEN.OPT
 L PCODE
 L SAFE.PC

The current menu level is shown in the Auxiliary Display in the top right corner of the LCD. The Parent Menu is shown in the Secondary Id. The Menu Item Name is shown in the Primary Display and the Item Data in the Secondary Display, and this will be blank in the case of a sub menu. Refer to 17 Appendix 4: Setup Menu Quick Reference page 135 for a listing of the overall menu structure.

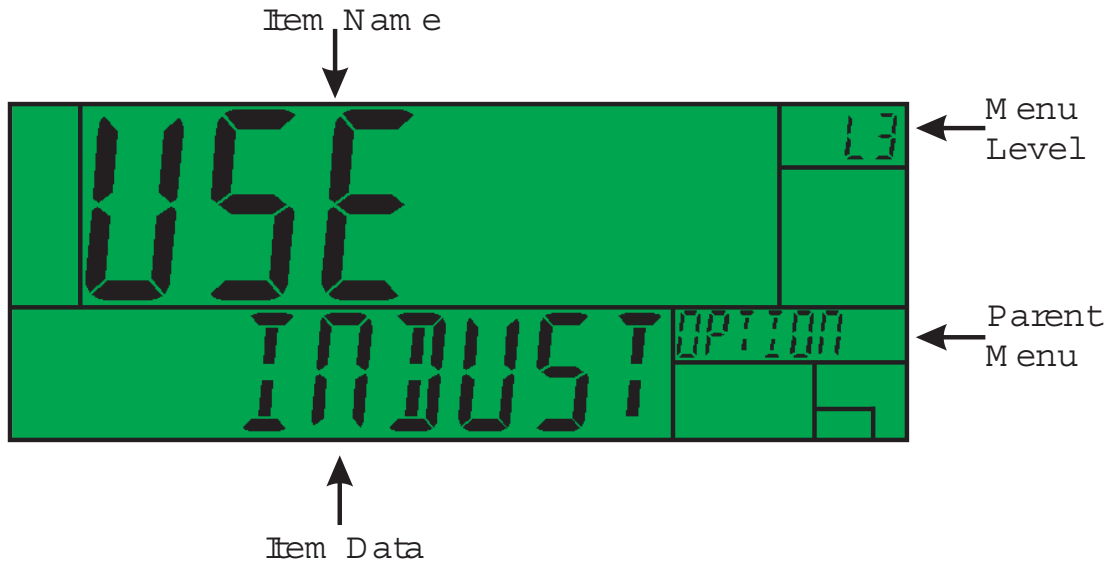

5.4. Data Entry

Throughout the setup menus different data entry methods are used. Each method is described below.

5.4.1. Changing Data

Menu items containing data are shown along with their data (strings may show the first few characters only). This data can be changed by using the editing keys. When editing is finished, press the <OK> key to accept the new data. If the new data is unwanted, press the cancel <C> key (sometimes several presses are required). While editing, the type of data being edited is shown in the top right corner of the LCD.

5.4.2. Numeric Entry

Using the keypad, enter the desired number and press the <OK> key. Upper and lower limits are placed on some entries and an entry outside this range will cause the instrument to display dashes (i.e. - - - -).

Example: When in Setup follow the steps below to set SCALE:BUILD:CAP1.

Press <ZERO> repeatedly to display the SCALE menu.
Press <TARE> repeatedly to display the BUILD menu.
Press <RECIPE> repeatedly to display the CAP1 item and the current setting (e.g. 30.00kg).
Enter the new capacity using the keypad.
Press <OK>

5.4.3. Selections and Options

A selection entry requires the choice of a single option from a list. Using the up and down arrows, select the desired option and press the <OK> key.

Example: When in Setup follow the steps below to set SCALE:BUILD:CABLE

Press <ZERO> repeatedly to display the SCALE menu.
Press <TARE> repeatedly to display the BUILD menu.
Press <RECIPE> repeatedly to display the CABLE item and the current setting (e.g. 4 WIRE).
Use the ↑ and ↓ keys to select the desired option from the list.
Press <OK>

5.4.4. Strings

There are 3 different methods of editing strings:

- Normal string editing (auxiliary display: STR) - most useful where strings are small and contain no lowercase or unprintable characters. The available characters are printed in orange on the keypad.
- Numerical string editing (auxiliary display: S.NUM) – useful where strings only contain numbers.
- ASCII string with character position (auxiliary display: S.ASC) -

Use the <+/-> key to cycle between these options. The following table lists the special keys and their functions for each type of editing.

	Normal and Numerical	ASCII
<OK>	Accept changes and finish	Accept changes and finish
<Long press of cancel>	Cancel and exit without changes	Cancel and exit without changes
<Cancel>	Delete character	Delete character
<Up>, <Down>	Move cursor	Move cursor
<Long press of down>	Delete string after cursor	Delete string after cursor
<+/->	Switch editing modes	Switch editing modes
<0> to<9>		Enter a new code

6. Scale Configuration

6.1. Scale Parameters (SCALE:BUILD)

The SCALE:BUILD setup menu defines key scale base parameters: 4/6 wire load cell (CABLE), decimal point position (DP), full scale capacity (CAP1), resolution (E1), range types, units (UNITS) and if high resolution (HI.RES) is required. For discussion on 4/6 wire load cell connection, refer to 3.8 Load Cell Connection page 10. These scale parameters are specified in the SCALE:BUILD menu, refer to 14.3.1 BUILD (Scale parameters) page 93 for the setup menu structure.

It is important to ensure the signal strength from the connected load cells is sufficiently high to match the capability of the instrument, especially when configuring a trade certified site. The trade approved capability of the instrument is quoted as a maximum number of divisions with minimum signal strength per division in micro-volts.

To illustrate the process, consider the following example: Four 2,500kg 2.0mV/V load cells are used in an application requiring a 5,000kg full scale, with weight displayed in 5kg increments.

Total number of divisions:	Total Number of Divisions = $\frac{\text{Fullscale}}{\text{Count-by}} = \frac{5000\text{kg}}{5\text{kg}} = 1000\text{divisions}$
Full scale load cell signal:	Fullscale signal = $\frac{\text{Fullscale}}{\text{Load Cell Capacity}} \times \text{Loadcell signal (at capacity)}$ $= \frac{5000\text{kg}}{10000\text{kg}} \times 2.0\text{mV/V} = 1.0\text{mV/V}$
Absolute signal voltage:	Absolute Signal Volatge = Excitation Voltage x Fullscale Signal $= 7.4\text{V} \times 1.0\text{mV/V} = 7.4 \text{ mV}$
Signal resolution:	Signal Resolution = $\frac{\text{Absolute Signal Voltage}}{\text{Number of graduations}} = \frac{7.4\text{mV}}{1000 \text{ divisions}}$ $= 0.0074\text{mV/division} = 7.4\text{uV/division}$

6.2. Scale Options (SCALE:OPTIONS)

The options for trade use (e.g. filtering, motion, zero range and tracking) are defined in the SCALE:OPTIONS menu. Refer to 14.3.2 OPTION (Scale options) page 94 for the setup menu listing all options. Filtering and trade use are discussed further below.

6.2.1. Industrial versus Trade Modes (USE)

The instrument may be operated in Industrial or Trade mode. These modes restrict certain aspects of the operation of the instrument to ensure compliance with trade certified standards. The following table lists the operation differences for each of these modes.

Element	Industrial	Trade
Underload	–105% of Fullscale	–1% or –2% of Fullscale depending on zero range setting
Overload	105% of Fullscale	Fullscale + 9 divisions
Tare	No restrictions	Tare values must be > 0
Test Modes	Unlimited time allowed	Limited to five seconds

Table 1: Industrial vs Trade Modes

6.2.2. Filtering Techniques (FILTER)

There is a trade-off between noise filtering and the step-response time of the system. The step-response is defined as the time between placing a weight on the scale and the correct stable weight reading being displayed. This does not affect the number of readings per second that are taken. It simply defines the amount of time that is required to determine a final weight reading.

The **FILTER** setting defines the amount of time over which the averaging is taken. Increasing the averaging time will result in a more stable reading but will extend the time it takes the instrument to settle to a final reading.

7. Calibration (SCALE:CAL)

Note: Some of the digital setup steps can affect calibration. The SCALE:BUILD and SCALE:OPTION settings MUST be configured before calibration is attempted.

The calibration of the indicator is fully digital and calibration results are stored in permanent memory for use on power up. To perform a calibration, use Full Setup and select the **SCALE:CAL** menu. Refer to 14.3.3 CAL (Scale calibration) page 95 for the setup menu.

Both calibration with weights (using ZERO and SPAN) and direct mV/V calibration (DIR.ZER and DIR.SPN) are supported. Linearisation for use on non-linear scales and the default calibration are accessed in the calibration setup menu.

The calibration programme will automatically prevent the instrument from being calibrated into an application outside of its specification. If an attempt is made to calibrate outside of the permitted range, an error message will be displayed, and the calibration will be abandoned. Refer to Appendix 5: Error Messages page 140.

Note: It should not be assumed that just because the instrument has successfully calibrated a scale, that the scale is correct for trade use. Always check the scale build against the approval specification.

7.1.1. Calibration Counter

Within Setup there are a number of critical steps that can affect the calibration and/or legal for trade performance of the instrument. If any of these steps are altered, the trade certification of the scale could be voided.

The instrument provides built-in calibration counter(s) to monitor the number of times the critical steps are altered. The value of a counter is stored within the instrument and can only be reset at the factory. Each time a critical step is altered, the counter will increase by one. Whenever the instrument is powered up, or setup mode is entered/exited, the current value in the counter is displayed briefly (e.g. C00010).

The value of the counter is written on the tamperproof trade label on the front of the indicator for trade-certified applications and functions as an electronic seal. If any legal for trade settings are changed on the instrument, the current value of the calibration counter will be different from the recorded value and the seal is broken. In this manual, items marked with ⊗ indicate that the setting is legal for trade critical settings.

7.1.2. Digital Calibration with Test Weights (ZERO and SPAN)

To perform calibration with test weights, ZERO and SPAN are used in the setup menus.

- The Zero setting (SCALE:CAL:ZERO) specifies a gross zero point for the scale.

- The Span setting (SCALE:CAL:SPAN) specifies a second point (**preferably close to full scale**) used to convert the A/D readings into weighing units (e.g. kg).

It is important that an initial zero calibration is performed before any span calibrations. The chart shown demonstrates how the zero and span points are used to interpolate a weight reading from the load cell reading.

Notes:

1. Calibration points (Zero, Span and Linearisation) must be spaced by at least 2% of Full scale from each other.
2. First span point must be 10% of full scale or greater for successful calibration.

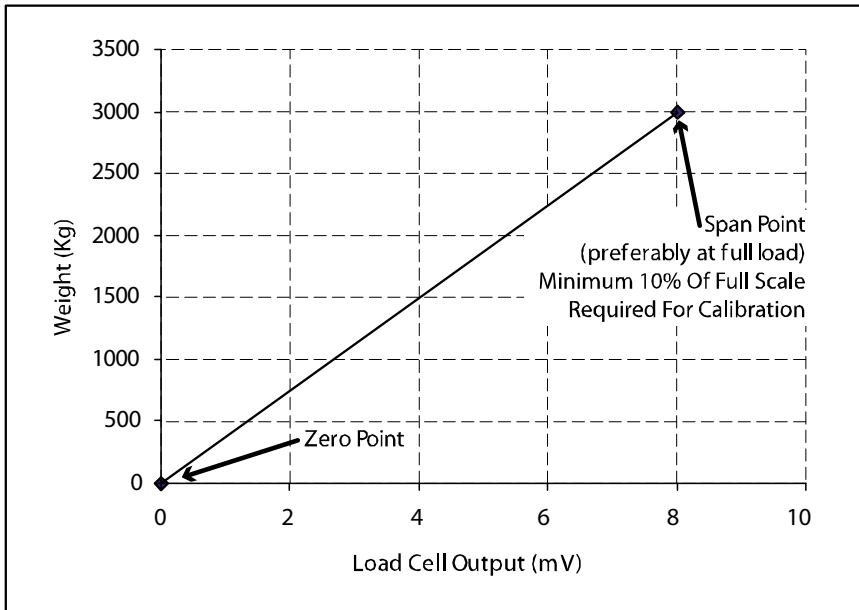
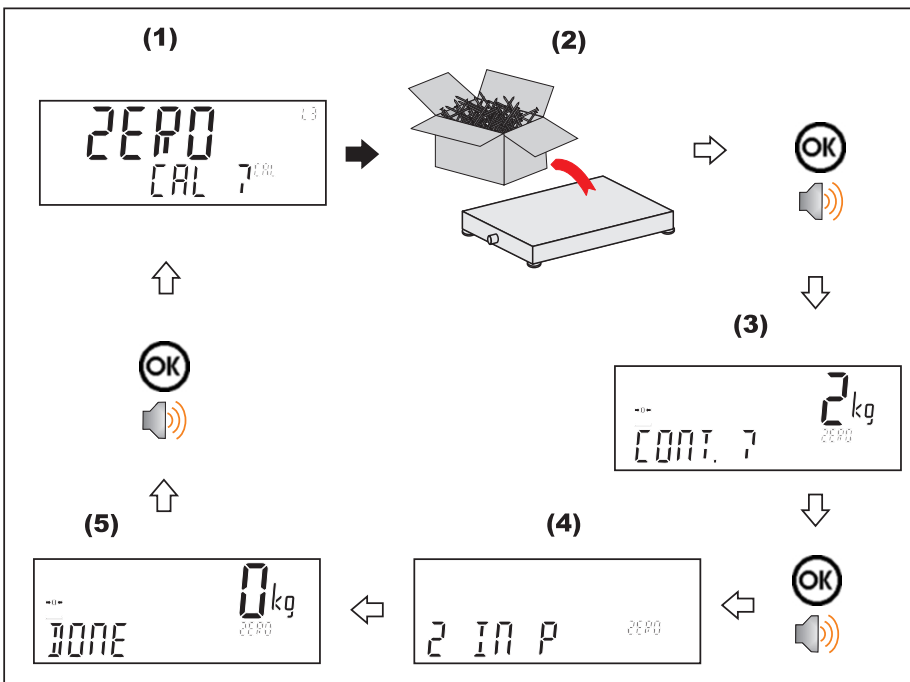
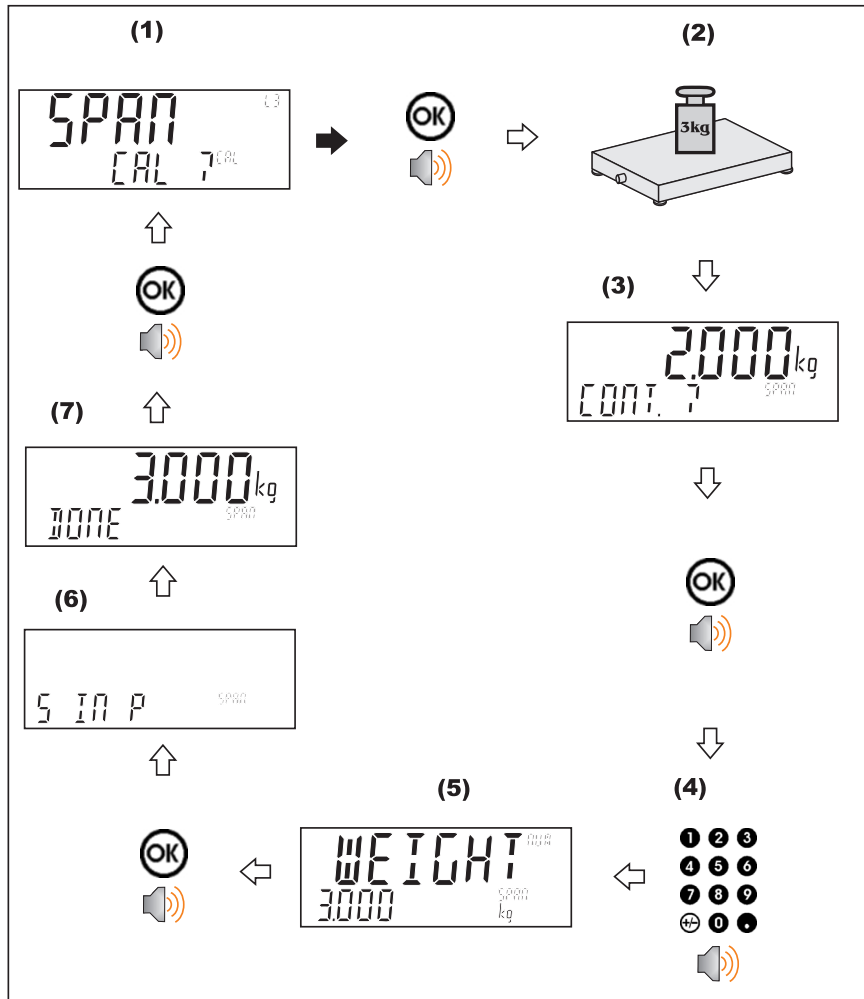

Figure 12: Chart - Zero and Span Points to Interpolate Weight from Load Cell

ZERO (Zero Calibration Routine)



SPAN (Span Calibration Routine)



7.1.3. Calibration with Direct mV/V Entry (DIR.ZER and DIR.SPN)

In applications where test weights are not easily available, it is possible to calibrate the instrument directly by entering the mV/V signal strength at Zero and Span.

- The Direct Zero setting (SCALE:CAL:DIR.ZER) specifies a gross zero point for the scale.
- The Direct Span setting (SCALE:CAL:DIR.SPN) specifies the mV/V signal strength corresponding to an applied mass.

This calibration technique is not compatible with linearisation. Clearly the accuracy of this type of calibration is limited to the accuracy of the direct mV/V data.

DIR.ZER (Direct Zero Calibration Entry)

Press the <OK> key to start. The display will show the current weight.
Press the <OK> key. Change the mV/V setting to the correct value for Zero and press the <OK> key. DONE will be displayed along with the weight to allow the reading to be checked.
Press the <OK> to leave the zero routine.

DIR.SPN (Direct Span Calibration Entry)

Press the <OK> key to start. The display will show the current weight.
Press the <OK> key. Change the weight to the correct value and press the <OK> key.
Change the mV/V setting to the correct value and press the <OK> key. DONE will be displayed along with the weight to allow the reading to be checked.
Press the <OK> to leave the zero routine.

7.1.4. Using Linearisation (ED.LIN and CLR.LIN)

Linearisation is used to approximate the weight output to a non-linear scale. The chart below shows a non-linear characteristic for the load cell output. From the chart, it can be seen that the trace with no linearisation applied is a poor approximation to the real characteristic. By applying one or more linearisation points, more accurate weight readings can be achieved.

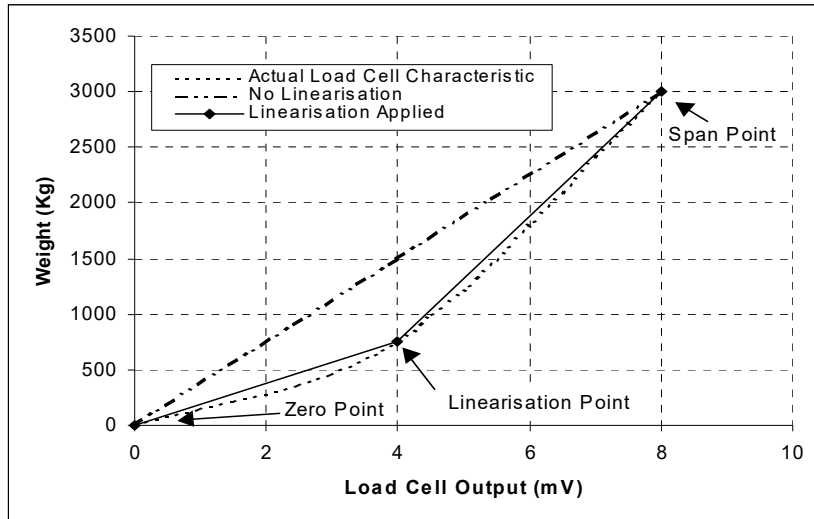
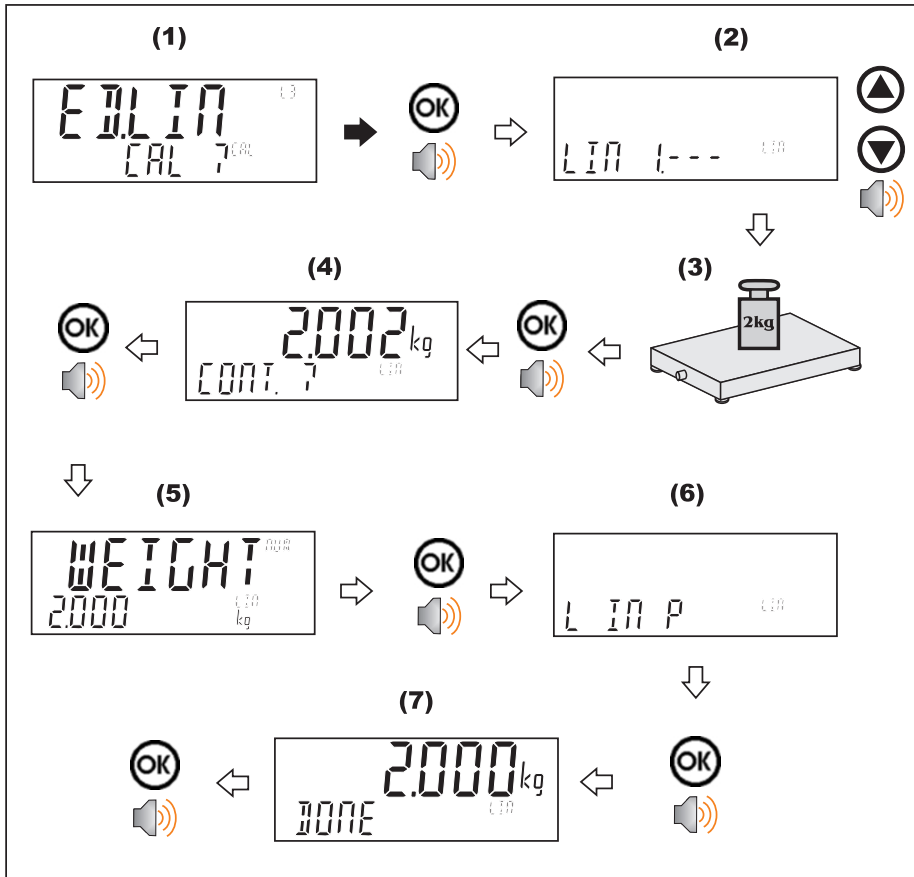

Figure 13: Chart - Non-Linear Characteristic for Load Cell Output

To perform a linearisation, a calibration of the zero and full scale span points must have been performed. Both the zero and full scale calibration points are used in the linearisation of the scale base. These two points are assumed to be accurately set and thus have no linearisation error.

A maximum of ten linearisation points can be set independently between zero and full scale. Unused or unwanted points may also be cleared. The maximum correction that can be applied using a linearisation point is +/- 2%.

ED.LIN (Edit Linearisation Points)



CLR.LIN (Clear Linearisation)

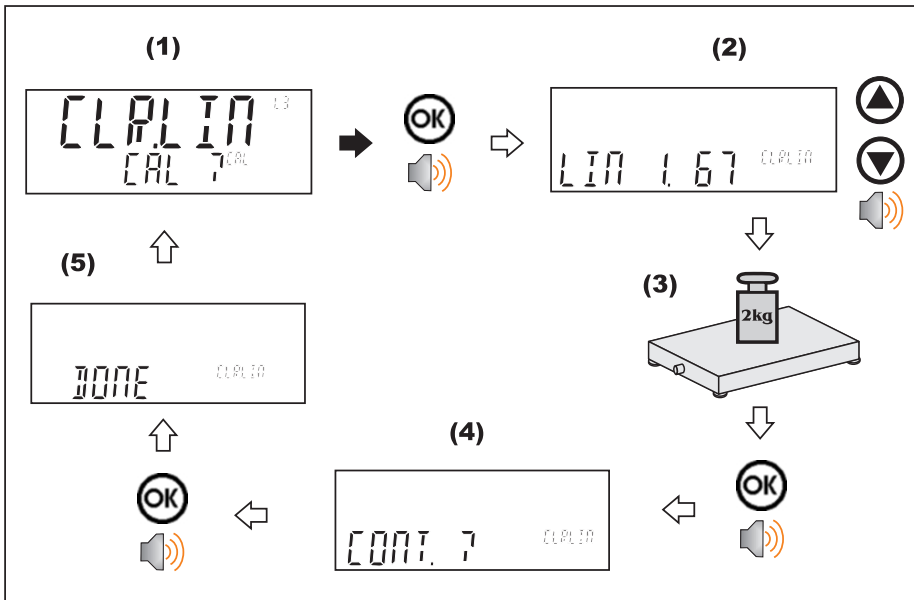

8. Network Protocol

8.1. Introduction

The RS-232, RS-485, Ethernet and the optical communications can be used for networking.

Serial communications parameters like BAUD, PARITY etc. for the RS232 or RS485 serial ports are setup in the hardware (H.WARE) menu, refer to H.WARE (Hardware Configuration & Test) page 88.

The Optical Communications port uses the optical communications cable and is fixed to operate at 9600 baud, no parity, 8 data bits and 1 stop bit.

Warning: The calibration counter is incremented when the calibration related settings are changed. This means that calibration via a serial port cannot be carried out without affecting the certification of a trade installation.

8.2. Network Protocol

The network protocol uses ASCII characters with a single master POLL / RESPONSE message structure. All information and services are provided by registers each of which has its own register address.

8.2.1. Basic Format

The basic message format is as follows:

ADDR	CMD	REG	:DATA	↵
-------------	------------	------------	--------------	----------

ADDR is a two-character hexadecimal field corresponding with the following:

ADDR	Field Name	Description
80 _H	Response	'0' for messages sent from the master (POLL). '1' for messages received from an instrument (RESPONSE)
40 _H	Error	Set to indicate that the data in this message is an error code and not a normal response.
20 _H	Reply Required	Set by the master to indicate that a reply to this message is required by any slave that it is addressed to. If not set, the slave should silently perform the command.
00 _H .. 1F _H	Indicator Address	Valid instrument addresses are 01 _H to 1F _H (1 .. 31). 00 _H is the broadcast address. All slaves must process broadcast commands. When replying to broadcasts, slaves reply with their own address in this field.

CMD is a two-character hexadecimal field:

CMD	Command	Description
05 _H	Read Literal	Read register contents in a 'human readable' format
11 _H	Read Final	Read register contents in a hexadecimal data format
12 _H	Write Final	Write the DATA field to the register.
10 _H	Execute	Execute function defined by the register using parameters supplied in the DATA field.
16 _H	Read Final (Decimal)	Same as Read Final except numbers are decimal
17 _H	Write Final (Decimal)	Same as Write Final except numbers are decimal

REG	is a four-character hexadecimal field that defines the address of the Register specified in the message. See Appendix 3: Communications Registers page 128 for a list of registers used by the instrument. The viewer software will show the register address for each setting in the menu structure when they are accessed.
: DATA	carries the information for the message. Some messages require no DATA (e.g. Read Commands) so the field is optional. When a DATA field is used a ':' (COLON) character is used to separate the header (ADDR CMD REG) and DATA information.
↵	is the message termination (CR LF or “;”).

Note: The hexadecimal codes are combined in the fields described above when multiple options are active at the same time. For example, an error response message from instrument address 5 would have an ADDR code of C5_H (80_H + 40_H + 05_H).

8.2.2. Termination

Message termination is possible in two ways.

- For normal communications that do not involve checksums use either a CRLF (ASCII 13, ASCII 10) as a terminator or a semicolon (;' ASCII). There is no start-of-message delimiter.
- To use a checksum the message is framed as:

SOH <Message> CRC EOT

SOH	ASCII 01
CRC	a 4-character hexadecimal field comprising the 16-bit CRC checksum. The CRC uses the 16-bit CCITT polynomial calculation and includes only the contents of the <Message> section of the transmission.
EOT	ASCII 04

8.2.3. Error Handling

If a command cannot be processed, the indicator returns an error. The ERROR bit in the ADDR field is set and the DATA field contains the Error Code as follows:

Error	DATA	Description
Unknown Error	C000H	Error is of unknown type
Not Implemented Error	A000H	Feature not implemented on this device
Access Denied	9000H	Passcode required to access this register
Data Under Range	8800H	Data too low for this register
Data Over Range	8400H	Data too high for this register
Illegal Value	8200H	Data not compatible with this register
Illegal Operation	8100H	CMD field unknown
Bad parameter	8040H	Parameter not valid for this execute register
Menu in Use	8020H	Cannot modify register values while SETUP menus are active
Viewer Mode required	8010H	Advanced operation chosen which requires the instrument to be in viewer mode.
Checksum required	8008H	A checksum is required for the chosen command.

Table 2: Network error codes

8.2.4. Ring Network Enhancement

Instruments with software revision V2.31+ can be configured in a Ring Network via a M42xx module (software revision 1.01+). This requires the central computer to send additional framing characters, 'Echo-On' (= <DC2> =ASCII 12 H) and 'Echo-Off' (= <DC4> =ASCII 14 H) around each command. Below is an example Ring Network command and response:

COMMAND

```
<DC2>20110150:<CR><LF>
<DC4>
```

RESPONSE

```
<DC2>20110150:<CR><LF>
81110150:07/01/2030 17-29<CR><LF>
82110150:07/01/2030 17-30<CR><LF>
<DC4>
```

8.2.5. Calibrating an instrument over a network

An instrument can be calibrated over a network using the network protocol. The registers relating to calibration are listed in Appendix 3: Communications Registers page 128 and marked with the symbol “*”. Note that changing the calibration of an instrument via the network will increment the calibration counters and void the scale certification.

These registers are protected by the full access passcode if it is being used. In this case, the Enter Full Passcode register is necessary in the process of calibration. If the rear button is used to access the menus normally, then a long press of the rear button will enter a mode that permits calibration via the network.

8.3. Network Protocol BARCODE (K411 and K412 only)

The barcode network protocol allows a barcode scanner to be connected to the instrument to select the product. The source setting allows the product to be selected based on its name, barcode, or ID number. To select the example product:

Name: abcdefghi
Barcode: 1234567890abcd
ID: 100

With barcode protocol source set to NAME send:

abcdefghi<CR><LF>

With barcode protocol source set to BARCODE send:

123456789abcd<CR><LF>

With barcode protocol source set to ID send:

100<CR><LF>

8.4. rinCMD Examples

Following are a list of examples of typical commands:

	Description
<p>Read Gross Weight (Read Final)</p> <p>COMMAND : 20110026↵</p> <p>RESPONSE : 81110026:00000064↵</p>	<p>COMMAND : Read Gross Weight (Register 0026): ADDR = 20H : Reply required from any instrument CMD = 11H : Read Final REG = 0026H : Gross Weight</p> <p>RESPONSE : Response is from instrument #1 which currently has a Gross weight of 64 H = 100 kg.</p>
<p>Read Gross Weight (Read Literal)</p> <p>COMMAND : 20050026↵</p> <p>RESPONSE : 81050026: 100 kg G↵</p>	<p>COMMAND : Read Gross Weight (Register 0026 H): ADDR = 20H : Reply required from any instrument CMD = 05H : Read Literal REG = 0026H : Gross Weight</p> <p>RESPONSE : Same response from instrument #1 but in literal format.</p>
<p>Set Print Header (Write Final, Execute)</p> <p>COMMAND A : 2112A381:Hello There↵</p> <p>RESPONSE A : C112A381:9000↵</p> <p>COMMAND B : 2112001A:4D2↵</p> <p>RESPONSE B : 8112001A:0000↵</p> <p>COMMAND C : 2112A381:Hello There↵</p> <p>RESPONSE C : 8112A381:0000↵</p> <p>COMMAND D : 21100010↵</p> <p>RESPONSE D :</p>	<p>COMMAND A : Write Print Header String (Register A381 H) ADDR = 21H : Reply required from instrument #1 CMD = 12H : Write Final REG = A381H : Print Header String DATA = 'Hello There'</p> <p>RESPONSE A : Instrument #1 reports "ERROR: Access Denied". (Writing to this register requires a passcode)</p> <p>COMMAND B : Enter SAFE SETUP Passcode (Register 1A H) ADDR = 21H : Reply required from instrument #1 CMD = 12H : Write Final REG = 1AH : Enter SAFE PASSCODE DATA = 4D2H (passcode is 1234)</p> <p>RESPONSE B : Instrument #1 reports Passcode Accepted</p> <p>COMMAND C : (resend COMMAND A) .</p> <p>RESPONSE C : Instrument #1 reports "Command Successful".</p>

Description	
81100010:0000↵	<p>COMMAND D:</p> <p>Save Settings (Register 10_H)</p> <p>ADDR = 21_H Reply required from instrument #1</p> <p>CMD = 10_H : Execute</p> <p>REG = 10_H : Save Settings</p> <p>RESPONSE D:</p> <p>Instrument #1 reports "Command Successful".</p>
Trigger Zero Button Press (Write Final)	<p>COMMAND A:</p> <p>Send down the Zero button key code.</p> <p>RESPONSE A:</p> <p>Instrument #1 reports "Command Successful".</p>
<p>COMMAND A:</p> <p>21120008:0B↵</p> <p>RESPONSE A:</p> <p>81120008:0000↵</p> <p>COMMAND B:</p> <p>21120008:8E↵</p> <p>RESPONSE B:</p> <p>81120008:0000↵</p>	<p>COMMAND B:</p> <p>Do a long press of the F1 key.</p> <p>RESPONSE B:</p> <p>Instrument #1 reports "Command Successful".</p>
Streaming (Write Final, Read Final, Execute)	<p>COMMAND A:</p> <p>Setup to read the displayed weight.</p> <p>RESPONSE A:</p> <p>Instrument #1 reports "Command Successful".</p>
<p>COMMAND A:</p> <p>21120042:06↵</p> <p>RESPONSE A:</p> <p>81120042:0000↵</p> <p>COMMAND B:</p> <p>21120043:11↵</p> <p>RESPONSE B:</p> <p>81120043:0000↵</p> <p>COMMAND C:</p> <p>21110040↵</p> <p>RESPONSE C:</p> <p>81110040:000005DB000009↵</p>	<p>COMMAND B:</p> <p>Setup to read the IO status.</p> <p>RESPONSE B:</p> <p>Instrument #1 reports "Command Successful".</p> <p>COMMAND C:</p> <p>Read the combined data.</p> <p>RESPONSE C:</p> <p>Data is concatenated. It is 8 hexadecimal digits each.</p> <p>COMMAND D:</p> <p>Set streaming to 3Hz.</p> <p>RESPONSE D:</p> <p>Instrument #1 reports "Command Successful".</p>

Description	
<p>COMMAND D: 21120041:03↵ RESPONSE D: 81120041:0000↵</p> <p>COMMAND E: 21100040:1↵ RESPONSE E: 81100040:00000000↵ 81110040:000005DB000 00009↵ 81110040:000005DB000 00009↵</p> <p>COMMAND G: 21100040:0↵ RESPONSE G: 81100040:00000000↵</p>	<p>COMMAND E: Start the automatic streaming.</p> <p>RESPONSE E: Instrument #1 reports "Command Successful" followed by streamed data at 3Hz.</p> <p>COMMAND G: Stop the automatic streaming.</p> <p>RESPONSE G: Instrument #1 reports "Command Successful".</p>

9. Automatic Weight Output

9.1. Overview

The automatic output is normally used to drive remote displays, a dedicated computer, or PLC communications. It is configured using the **SER.AUT** menu, refer to 14.6 SER.AUT (Automatic transmit) page 101 for the setup menu structure. The RS-232 or the RS-485 port can be used.

The rate of transmission is set by the TYPE setting. AUTO.LO and AUTO.HI send unsolicited messages at 10Hz and 25Hz respectively. SINGLE only sends messages when a SINGLE input is received from an external input. This enables external systems like PLCs to synchronise the AUTO output to their requirements.

9.2. Auto Weight Format String

The weight format string may be set to the following formats:

Format	Description
FMT.A	<STX> <SIGN> <WEIGHT(7)> <STATUS> <ETX>
FMT.B	<STX> <S0> <SIGN> <WEIGHT(7)> <UNITS(3)> <ETX>
FMT.C	<STX> <SIGN> <WEIGHT(7)> <S1> <S2> <S3> <S4> <UNITS(3)> <ETX>
FMT.D	<STX> <SIGN> <WEIGHT(7)> <ETX>
FMT.E	<STX> <SIGN> <WEIGHT(7)> <S5> <UNITS(3)> <MODE(4)> <ETX>
FMT.REG	ADDR CMD REG : DATA
FMT.TRC	CONSEC SP DATE SP TIME SP TRACE <CR><LF>
CUSTOM	As per contents of the EV.AUTO token string.
FMT.G	<STX> <SIGN> <WEIGHT(7)> <S1> <S2> <S3> <S4> <UNITS(3)> <ETX>

Table 3 - Auto Weight Format Strings

Description	Explanation
STX	Start of transmission character (ASCII 02).
ETX	End of transmission character (ASCII 03).
SIGN (except FMT.G)	The sign of the weight reading (space for positive, dash (-) for negative).
SIGN (FMT.G only)	<p>The sign of the weight reading and serial traffic light control. Both the sign character and traffic lights can be displayed at the same time.</p> <p>0x20 = No Sign or Traffic light 0x2D = '-' Sign 0x30 = RED 0x3D = Red and '-' Sign 0x60 = GREEN 0x6D = GREEN and '-' Sign 0x70 = RED + GREEN 0x7D = RED + GREEN and '-' Sign</p> <p>Example: 0x60 will display a Green but no negative sign 0x6D will display both the Green and the negative sign Setpoint 1 is mapped to the red light and setpoint 2 is mapped to the green light.</p>
WEIGHT(7)	A seven-character string containing the current weight including the decimal point. If there is no decimal point, then the first character is a space. Leading zero blanking applies.
S0	Provides information on the weight reading. The characters G/N/U/O/M/E represent Gross / Net / Underload / Overload / Motion / Error, respectively.
UNITS(3)	A three-character string, the first character being a space, followed by the actual units (e.g. ^kg or ^t). If the weight reading is not stable, the unit string is sent as ^^^.
S1	Displays G/N/U/O/E representing Gross / Net / Underload / Overload / Error, respectively.
S2	Displays M/^ representing Motion / Stable, respectively.
S3	Displays Z/^ representing centre of Zero / Non-Zero, respectively.
S4	Displays - representing single range.
S5	Displays “/”m”/”c” representing Stable / Motion / Overload or Underload
Mode	Displays “_g__” or “_n__” for gross or net weight.
‘ADDR CMD REG DATA’	This is the same format as the response from a READ FINAL network command. The SOURCE setting selects which register is selected
SP	Space character
CONSEC	Consecutive Print ID
DATE, TIME	Date and Time
TRACE	Traceable weight display

Table 4 - Auto Weight String Descriptors

10. Printing

10.1. Overview

The instrument can have up to two (2) printouts configured in the PRINT setup menu. There are 6 standard print formats as well as full printout customisation. The printer output may connect to a printer, data logger or remote display. Refer to 14.7 PRINT (Printouts page 102 for the setup menu. The various print formats are defined in the PRINT menu. Three (3) types of printouts are defined for different applications:

- **RECORD:** A Record printout gives the weight status. A printout of this type would be used by a special function PRINT key. To setup a special function PRINT key refer to 14.4.4 SFn: PRINT (Printing Functions) page 97;
- **BATCH:** Batch printouts contain batching specific information and are used within the batching process. For the setup menu refer to 14.9.2 GEN (General) page 109 and 14.7 PRINT (Printouts page 102);
- **REPORT:** Reports are used to print stored accumulated batch data (e.g. total material usage). Reports can be printed using the REPORT key (long press 3 key) or by setting up a special function REPORT key, refer to 14.4.4 SFn: PRINT (Printing Functions) page 97 for the setup menu;

There are two fixed formats for each printout type in addition to custom printing. The format of these printouts is shown below.

For custom printing each print event has an associated token string which includes literal ASCII text along with special token characters that are expanded at the time of printing to fields like weight, time, and date.

10.2. Print ID

A unique Consecutive Print ID appears on record printouts. It cannot be cleared and increments for every print. Additionally, a Settable Consecutive Print ID is available through custom printing and BATCH printing. It can be viewed and edited through the operator interface User ID key (long press key 5).

10.3. Record printouts

Format	Example
FMT.A	000001401 01/11/06 21:23:16 600kg G
FMT.B	Joe's Concrete 30 Yarmouth Pde Tamworth NSW 2040 01/01/2003 11:30 ID: 000000058 T: 5.0 kg G: 100.4 kg N: 95.4 kg Thank You!
CUSTOM	Format defined by REC.PRN token string.

10.4. Batch printouts

Batch printouts allow for print events during and at the end of a batch (or at the end of a series of batches when a set number of batches are being run).

Single or Continuous Batching

The following formats are available when a single batch is run or continuous batching. Each example is for one batch. Format A is the batch ID, date, time, and batched weight printed at the end of the batch. Format B is:

- Header
- Batch ID, date, and time
- The material name, filled weight, and target for each fill
- The total batched weight and target
- Footer

Format	Example
FMT.A	000001401 01/11/06 21:23:16 800kg
FMT.B	Joe's Concrete 30 Yarmouth Pde Tamworth NSW 2040 000001399 01/11/06 21:22:45 CEMENT 100kg (TARGET: 100kg) GRAVEL 500kg (TARGET: 500kg) ASH 200kg (TARGET: 200kg) TOTAL 800kg (TARGET: 800kg) Thank You!
CUSTOM	BAT.ST (Event Batch Start) defines what is printed at the start of a batch. BAT.END (Event Batch End) defines what is printed at the end of a batch. FILL (Event Fill Stage) defines what is printed at end of a fill stage. DUMP (Event Dump Stage) defines what is printed at end of a dump stage. PULSE (Event Pulse Stage) defines what is printed for a pulse stage ABORT (Event Abort) defines what is printed when a batch is aborted.

Set Number of Batches to Run

When a set number of batches is running (a series of batches), batched totals for the series is also printed. In the example below there are two batches (800kg each) in the series, making the total 1600kg.

Format	Example
FMT.A	<pre> Joe's Concrete 30 Yarmouth Pde Tamworth NSW 2040 000001397 01/11/06 21:23:16 800kg 000001398 01/11/06 21:24:16 800kg TOTAL 1600kg Thank You! </pre>
FMT.B	<pre> Joe's Concrete 30 Yarmouth Pde Tamworth NSW 2040 000001399 01/11/06 21:22:45 CEMENT 100kg (TARGET: 100kg) GRAVEL 500kg (TARGET: 500kg) ASH 200kg (TARGET: 200kg) TOTAL 800kg (TARGET: 800kg) Thank You! Joe's Concrete 30 Yarmouth Pde Tamworth NSW 2040 000001400 01/11/06 21:22:52 CEMENT 100kg (TARGET: 100kg) GRAVEL 500kg (TARGET: 500kg) ASH 200kg (TARGET: 200kg) TOTAL 800kg (TARGET: 800kg) Thank You! TOTAL 1600kg </pre>
CUSTOM	<p>BAT.ST (Event Batch Start) defines what is printed at the start of a batch.</p> <p>BAT.END (Event Batch End) defines what is printed at the end of a batch.</p> <p>FILL (Event Fill Stage) defines what is printed at end of a fill stage.</p> <p>DUMP (Event Dump Stage) defines what is printed at end of a dump stage.</p> <p>PULSE (Event Pulse Stage) defines what is printed for a pulse stage</p> <p>ABORT (Event Abort) defines what is printed when a batch is aborted.</p> <p>SER.ST ** (Event Series Start) defines what is printed at the start of a series of batches.</p> <p>SER.END ** (Event Series End) defines what is printed at the end of a series of batches.</p>

10.5. Report printouts

Reports print the batch data accumulated since the last time totals were cleared by the operator. The option to clear totals is available through either the Total key (long press 4 key) or the Report key (long press 3 key).

All Report printouts will be available to the operator through the Report key (long press 3 key) as long as the reports has been setup with a name. Alternately, through Special Functions, a dedicated Report key can be configured.

Format	Example
FMT.A	Joe's Concrete 30 Yarmouth Pde Tamworth NSW 2040 22/11/06 15:51:44 CEMENT 1000kg 10 0.41% GRAVEL 5000kg 10 0.12% ASH 2000kg 10 0.30% TOTAL 8000kg 30 0.20% Thank You!
FMT.B	Joe's Concrete 30 Yarmouth Pde Tamworth NSW 2040 22/11/06 15:51:44 CONCRETE 8000kg 10 TOTAL 8000kg 10 Thank You!
CUSTOM	REP.ST (Report Start) defines the start of the report. REP.PR (Report Product) defines what is printed for each product/recipe (currently one supported) REP.MAT (Report Material) defines what is printed for each material. REP.END (Report End) defines the end of the report.

10.6. Custom printing

Below are some examples of batch printouts and reports and their associated custom print strings.

Batch example print outs	Custom print strings
Joe's Concrete 30 Yarmouth Pde Tamworth NSW 2040 000001397 01/11/06 21:23:16 800kg 000001398 01/11/06 21:24:16 800kg <p style="text-align: right;">TOTAL</p> 1600kg Thank You!	BAT.END: \BC\D5 \BF \C0 \DE\C1 SER.ST: \B8\EC\C3\C1\C6\C1 SER.END: TOTAL \B8\DD\C1\C7\C1\C4 ABORT: \BD ABORT:\EB \C0\C1
Joe's Concrete 30 Yarmouth Pde Tamworth NSW 2040 000001399 01/11/06 21:22:45 CEMENT 100kg (TARGET: 100kg) GRAVEL 500kg (TARGET: 500kg) ASH 200kg (TARGET: 200kg) TOTAL 800kg (TARGET: 800kg) Thank You!	BAT.ST: \C3\C1\C6\C1\D5 \BF \C0\C1 BAT.END: \BCTOTAL \DE (TARGET:\E0)\C1 SER.ST: \B8\EC SER.END: TOTAL \B8\DD\C1\C4 FILL: \BD\D7 \DE (TARGET:\E0)\C1 ABORT: \BD ABORT:\EB \C0\C1

Report example print outs	Custom print strings
Joe's Concrete 30 Yarmouth Pde Tamworth NSW 2040 22/11/06 15:51:44 CEMENT 1000kg 10 0.41% GRAVEL 5000kg 10 0.12% ASH 2000kg 10 0.30% TOTAL 8000kg 30 0.20% Thank You!	REP.ST: \C3\C6\C1\BF \C0\C1 REP.MAT: \B6\D7 \D9 \DC \DA\C1 REP.END: \B8TOTAL \D9 \EA \DA\C1\C7\C1\C4
Joe's Concrete 30 Yarmouth Pde Tamworth NSW 2040 22/11/06 15:51:44 CONCRETE 8000kg 10 TOTAL 8000kg 10 Thank You!	REP.ST: \C3\C6\C1\BF \C0\C1 REP.PR: \BA\D7 \D9 \DC\C1 REP.END: \B8TOTAL \D9 \DC\C1\C7\C1\C4

11. Setpoints

11.1. Overview

Up to eight (8) setpoints are supported and each is independently configured to one of a number of functions (e.g. zero, motion, fill). Each setpoint can be associated with a given output. They can be configured to flash the instrument display, sound a buzzer, or drive a physical output. Refer to 14.8 SETP (Setpoints) on page 105 for the setup menu structure.

11.2. Outputs

The instrument supports 32 input/output control points. The application software uses these control points to decide what the control functions are, and the accessory modules respond according to their specific hardware.

Setpointing requires the use of outputs so it is important to select IO control points that have associated hardware output drivers that suit your application.

Five (5) of the setpoint types are for batching related functions. When outputs are defined with these types of setpoints they are essentially active all the time and are used to synchronise external systems to the batching process.

11.3. Common Settings

There are a number of settings that are common to all setpoint types. These are as follows:

- **OUTPUT:** Selects which IO control point to use. Options are NONE, IO1..IO32. NONE is useful if the setpoint is only being used to trigger an alarm.
- **LOGIC:** This setting determines whether the output is normally on or normally off. Logic HIGH means the output follows the activity of the setpoint and is on when the setpoint conditions are met. Logic LOW reverses the operation of the output.

For example: Consider a Centre-of-Zero status setpoint. This type of setpoint is active when the Centre-of-Zero annunciator is lit. With logic HIGH an output would turn on whenever the Centre-of-Zero annunciator was lit. With logic LOW the output would turn off when the Centre-of-Zero annunciator is lit and remain on otherwise.

Note that the outputs revert to the off state when the instrument SETUP menus are active.

- **ALARM:** Selects what alarm response is triggered when the setpoint is active. SINGLE sounds a single beep every two seconds, DOUBLE sounds a double beep every two seconds and FLASH flashes the instrument display. Note that the Alarm conditions are not influenced by the LOGIC setting, that is they follow the activity of the setpoint regardless of the physical state of the output.
- **TIMING(Not in K410):** Select the output timing of the setpoint. The following examples are explained in the context of an OVER setpoint however the timing options are available for all setpoint types.

Options are:

- **LEVEL:** the setpoint is active whenever the weight has gone over the target, has not dropped below the hysteresis value and the reset input is not currently active.
- **EDGE:** The setpoint becomes active when the weight goes over the target. The setpoint becomes inactive when the weight goes below the hysteresis value or the reset input becomes active.
- **PULSE:** Once the weight goes over the target the setpoint will begin the delay time. Once that time has elapsed the output will become active for the on time. If the pulse number (PLS.NUM) has been set for more than one, then the cycle will repeat for the set number of times. The reset input becoming active is the only reason the set number of cycles will not be completed; the weight is completely ignored once the cycle has started.
- **LATCH:** The setpoint becomes active when the weight goes over the target. The setpoint becomes inactive when the reset input becomes active.
- **RESET(Not in K410):** Select which IO is used as an input to disable the setpoint. Options are NONE, IO1..IO32.
- **RST.LGC(Not in K410):** This setting determines whether the input used to reset the setpoint is active when the value is LOW or HIGH.
- **DELAY:** If the timing has been set to PULSE this sets the delay before each pulse.
- **ON:** If the timing has been set to PULSE this sets the duration of each pulse.
- **PLS.NUM:** If the timing has been set to PULSE this sets the number of pulses to be output each time the setpoint is triggered.
- **NAME(Not in K410):** Name the setpoint. This will be shown when editing targets for OVER and UNDER type setpoints.

11.4. Weigh in (OVER) Setpoints and Weigh Out (UNDER) Setpoints

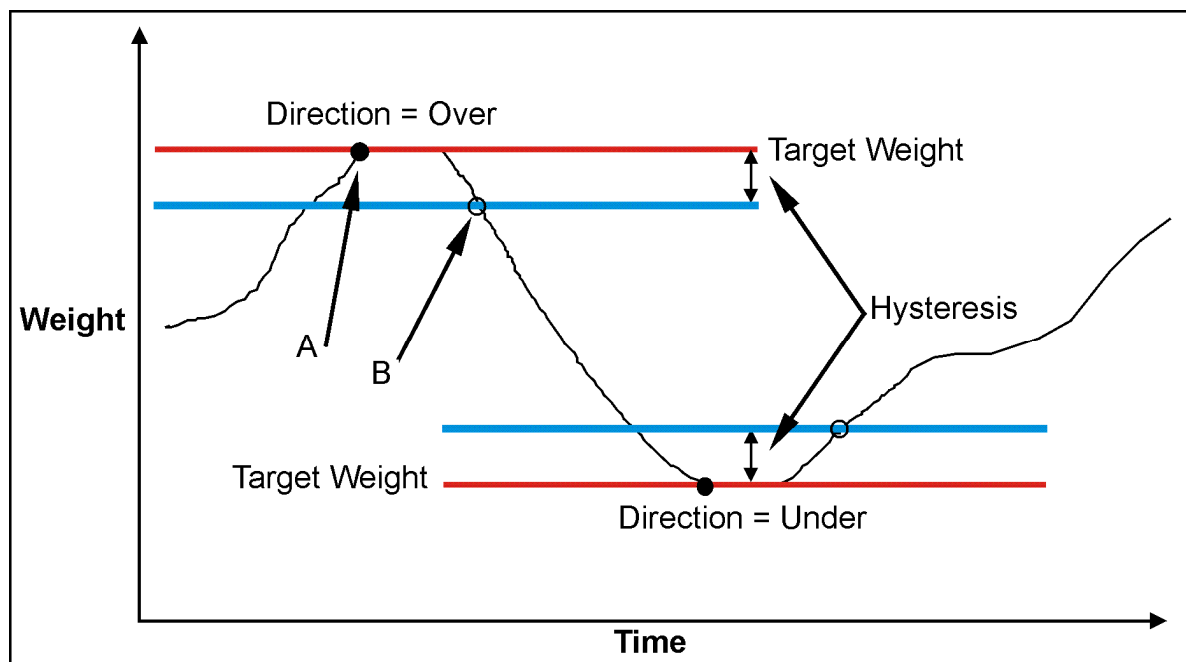

LOGIC	Point A	Point B
HIGH	ON	OFF
LOW	OFF	ON

Figure 14: OVER vs. UNDER setpoints

11.4.1. Additional Settings

In addition to the common settings, the following settings control the operation of the OVER and UNDER setpoints

- **SOURCE:** Select the weight source for the setpoint to use.

Options are:

- GROSS uses gross weight only
- NET uses net weight only
- 'GR or NT' uses either Gross or Net depending on which is currently displayed.
- REG(Not in K410): uses a register value.
- **Hysteresis (HYS):** This setting determines the change in weight required for an active setpoint to become inactive again. A value of zero still leaves 0.5 graduations of hysteresis.
- **REG(Not in K410):** If the source is set to register (REG) then this setting is used to set the register to use. The register must be a number or weight value.

11.4.2. Status Based Setpoint Types

The following setpoint types are all based on the **status of the instrument**.

- **NONE**: Setpoint is always inactive.
- **ON**: Setpoint is always active. This type of setpoint is useful to show that the instrument is running.
- **Centre of Zero (COZ)**: Setpoint is active when COZ annunciator is lit.
- **ZERO**: Setpoint is active when the weight is within the Zero Band setting.
 - **SOURCE**: The ZERO setpoint also has a SOURCE setting to determine if the zero condition is based on the gross or net reading. The GR or NT option uses the currently selected weight (gross or net).
- **NET**: Setpoint is active when the NET annunciator is lit.
- **MOTION**: Setpoint is active when the MOTION annunciator is lit.
- **ERROR**: Setpoint is active when the instrument detects any error condition signified by the display of Exxxxx on the primary display.
- **BUZZER**: Setpoint is active when the buzzer beeps.

11.5. Batching Based Setpoint Types

When outputs are defined with these setpoint types they are essentially active all the time and can be used to synchronise external systems to the batching process.

The status outputs are:

- **Out of Tolerance (TOL)**: Output active if an out-of-tolerance condition is detected on the batch, even if the batch is resumed after pause.
- **PAUSE**: Output active if batch paused.
- **WAIT**: Output active if batch waiting for dump enable input.
- **RUN**: Output active while batch is running, including when the batch is actually paused.
- **FILL**: Output active whenever any filling stage is running.

11.6. Logic Setpoint Types

The following setpoint types are all based on the status of the inputs and the mask.

- **LGC.AND**: Output active all inputs in the MASK are on.
- **LGC.OR**: Output active any inputs in the mask are on.
- **LGC.XOR**: Output active if only one input in the mask is on.

SOURCE: Select the source for the setpoint to use. K410 is fixed to the external IO option. K411 and K412 have the following options:

- **IO** use the external IO
- **Status** use the instrument status
- **SETP** use the setpoint status
- **REG** use a register value

MASK: a 32-bit number that is used to match IO1-IO32 for the logic setpoints.

DLY.ON: delay before setpoint becomes active.

HLD.OFF: delay before setpoint becomes inactive.

Status info	Bit
Spare	32
Jog	31
No Type	30
Start	29
Pulse	28
Dump	27
Fill	26
No Information	25
Input	24
Time	23
Fast	22
Medium	21
Slow	20
Pause	19
Run	18
Idle	17
No errors	16
Overload	15
Underload	14
Error	13
Preset tare not active	12
Preset tare active	11
High range	10
Low range	9
Stable	8
Motion	7
Not centre-of-zero	6
Centre-of-zero	5
Not Zero	4
Zero	3
Gross	2
Net	1

Table 5: Instrument Status for Logic Setpoints

SETP info	Bit
Unused	25-32
Not setpoint 8	24
Not setpoint 7	23
Not setpoint 6	22
Not setpoint 5	21
Not setpoint 4	20
Not setpoint 3	19
Not setpoint 2	18
Not setpoint 1	17
Unused	9-16
Setpoint 8	8
Setpoint 7	7
Setpoint 6	6
Setpoint 5	5
Setpoint 4	4
Setpoint 3	3
Setpoint 2	2
Setpoint 1	1

Table 6: Setpoint Status for Logic Setpoints

12. Analogue Output

12.1. Overview

The instrument supports a single analogue output used for analogue weight transmission. Setting up a system is a two-stage process:

- First install the analogue output hardware and configure the accessory module using the options in the H.WARE:ANL.HW menu.
- Second, configure the parameters of the information to be sent to the analogue output from the ANL.OUT menu.

12.2. Configuration of Hardware

12.2.1. Configuration

TYPE: Set the TYPE to VOLTAGE (0..10V) or CURRENT (4..20mA). The analogue accessory will light an LED to indicate which output type is active.

CLIP: The CLIP setting determines if the analogue output is allowed to extend past the nominal limits. If CLIP is ON, the output will not go below 0V or above 10V for voltage outputs. For current output the limits are 4mA and 20mA. If CLIP is OFF the voltage can extend an extra 0.5 Volts or so past the limits and the current can extend from 0mA to 24mA.

12.2.2. Calibration

Calibrate the lower and upper values of the analogue output using the CAL.LO and CAL.HI functions. Use the UP and DOWN arrows to adjust the output to the external system.

12.2.3. Testing

The analogue output can be driven to any value using the FRC.OUT function. Use the UP and DOWN arrows to move the output up and down to test that the values shown on the instrument display match the readings taken externally.

12.3. Analogue Weight Transmission

ABS (Absolute): This setting allows negative weight readings to be treated as positive values for the purposes of the analogue output transmission and is useful when transmitting negative net readings in WEIGH-OUT applications.

SOURCE: Used to determine what weight readings are to be sent. Options include gross weight always (GROSS), net weight always (NET) or gross or net readings depending on which is selected and currently displayed on the main display.

When **RANGE** is set to **CUSTOM**, **WGT.LO** (Weight Low) and **WGT.HI** (Weight High) settings specify the weight range that corresponds to the analogue output range. For example, it is possible to set the instrument up to send a 0..10V signal between 10.0 kg and 20.0kg even though the scale is calibrated to measure weight from 0.0kg to 50.0kg. This effectively increases the resolution of the analogue output over the weight range of interest.

13. Batching

13.1. Terminology

Recipe/Product – A recipe is made up of materials, their quantities, and the steps to create a product. A product also includes accumulated total information. The v1.x software supports one product with one recipe, the v2.x software supports 100 products each with one recipe.

Material – K410 has one (1) material, K411 has a maximum of six (6) materials and K412 has a maximum of twenty (20) materials. A material is specified for each FILL stage and a given material can be used by more than one stage. For K412, the materials are set per product. The operator sets the in-flight and preliminary targets, if multiple speed, for each material.

Batch – is the process for creating one quantity of product. The batch process is defined by up to ten (10) stages. The option exists for the operator to set the number of batches to be executed and manage the proportional quantities of product produced by weight or percentage.

Stage – a stage is a self-contained control unit with its own settings. A stage can be a FILL, DUMP or PULSE. Batching proceeds from one stage to the next in the order they are defined in the setup. Only one stage is active at a time.

Example: The **recipe/product** is for concrete. A **batch** of concrete is produced by stepping through four (4) **stages**: 1) FILL of gravel, 2) FILL of cement, 3) FILL of water then a 4) DUMP. The process uses three (3) **materials**, gravel, cement, and water.

13.2. Predefined Applications (K411 and K412 only)

A set of predefined applications are available as a starting point for batching menu setup. These applications vary the number of materials used (FILL stages) and the number of fill speeds. Each application includes a DUMP to weight stage.

Select an application closest to the configuration to be implemented as a starting point. Stages can be added and deleted as required and all settings can be modified as per normal setup.

Multiple feeders and auto flight correction are selected in the applications; again, these can be changed as required. Flight averaging is preset to two (2).

Refer to 14.9.1 APP (Applications) (K411 and K412 only) page 108 for the setup menu structure.

13.3. Stage Types

The instrument allows for three (3) stage types to be defined, FILL, DUMP, and PULSE. As only one stage can be active at a time it is possible for some services to be shared between stages. For example, multiple filling stages can share the same interlock inputs or even the same filling outputs as there is no possibility of clashes between the stages. This is not true for setpoints which are active all the time and must use independent outputs. It is possible to have multiple filling stages of the same material interposed with other material fills, pulsed outputs or even dump stages.

13.3.1. FILL Stage

Each FILL stage allows for a single material to be filled using single, double, or triple speed filling. These can be concurrent or one after another. Within a FILL stage, there can be:

- start and end time delays;
- fill interlock input;
- start condition of an auto tare; and
- error correction using jogging.

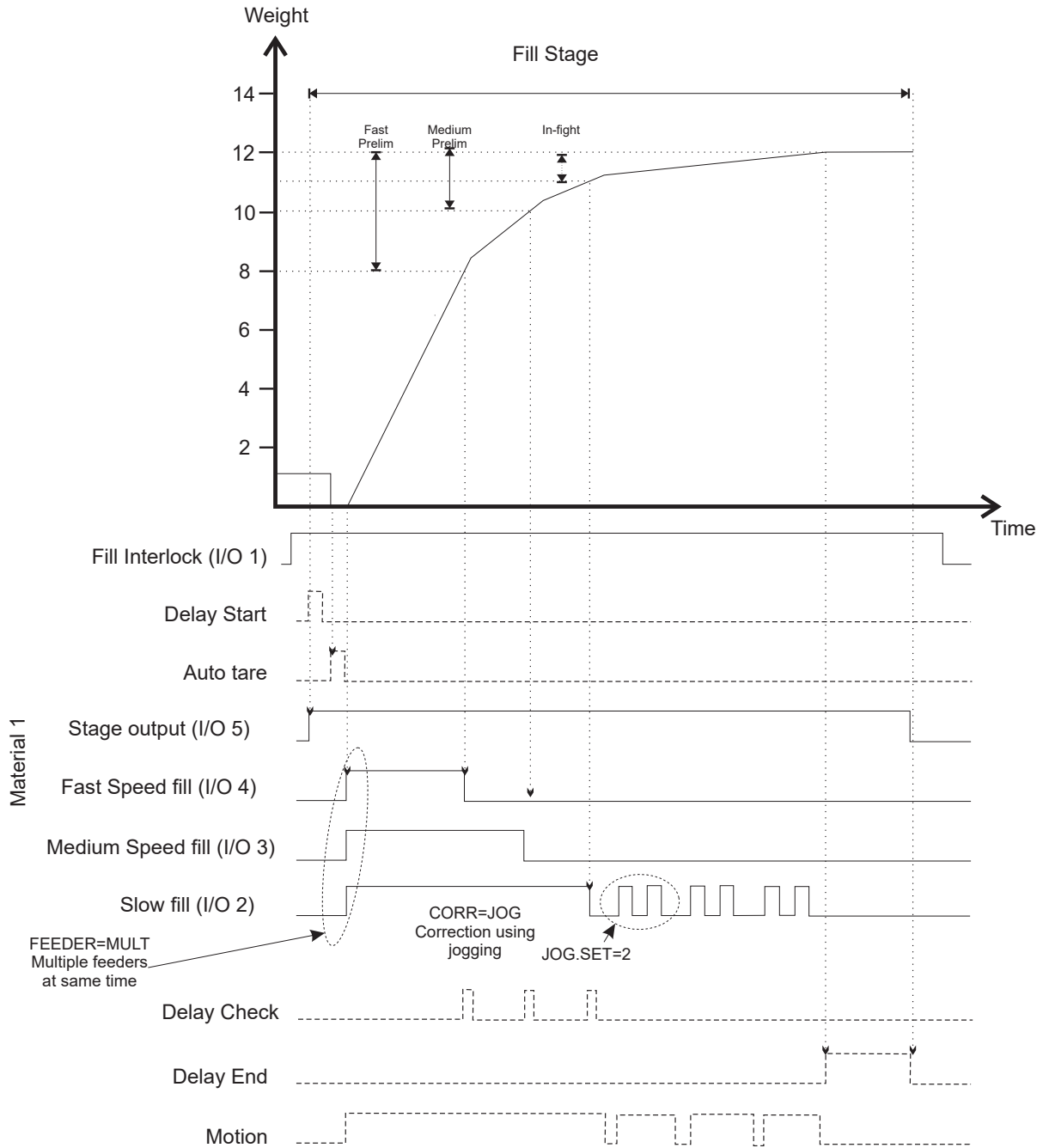

13.3.2. DUMP Stage

A DUMP stage allows for a dump to weight or time. Within a DUMP stage there can be:

- start and end time delays;
- dump interlock input;
- dump enable input; and
- error correction using jogging when dumping to weight.

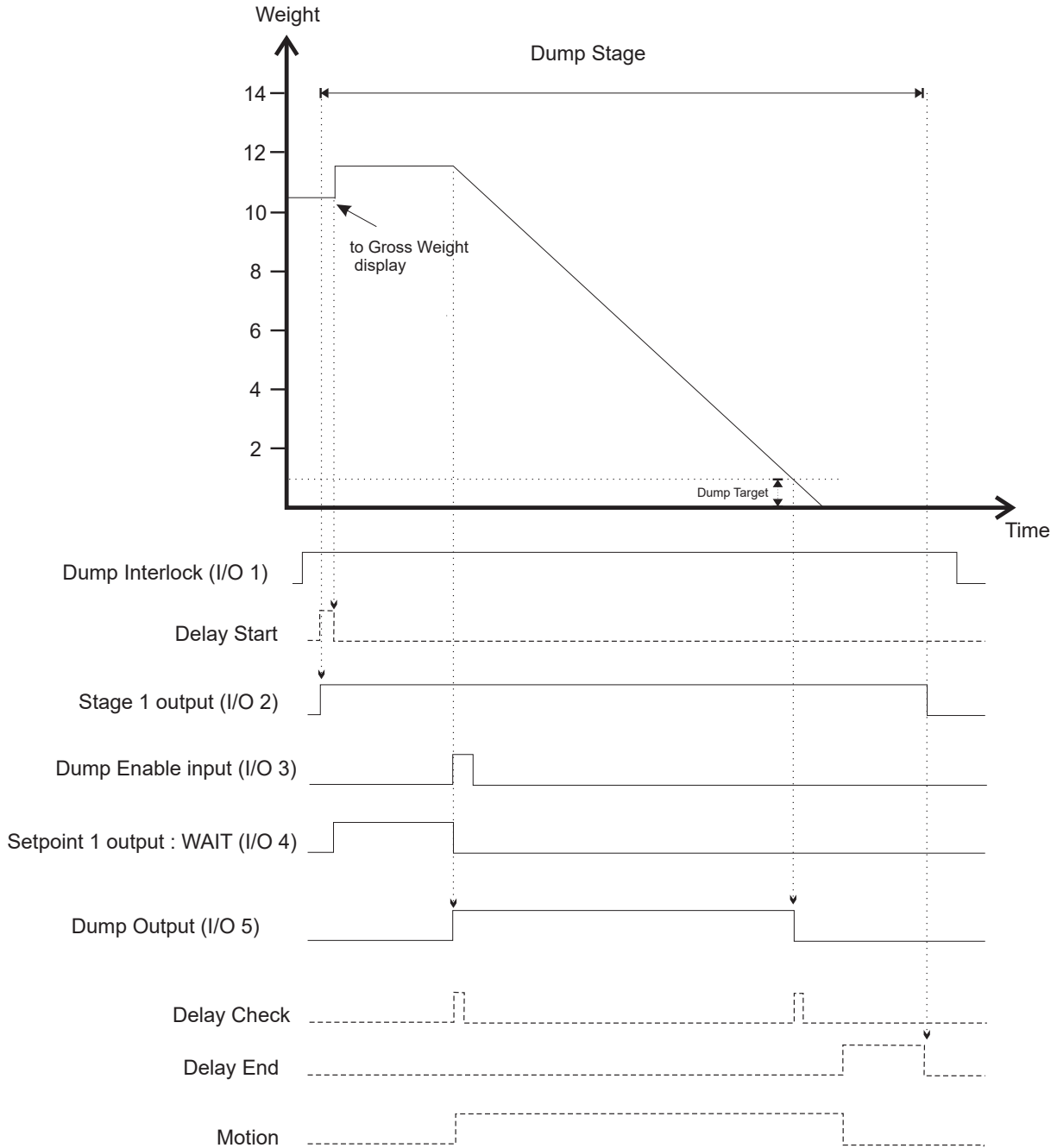

13.3.3. PULSE Stage

A PULSE stage will drive an output for the duration set by the operator and or allows an indeterminate wait to occur. The wait is ended via an operator key press or input signal.

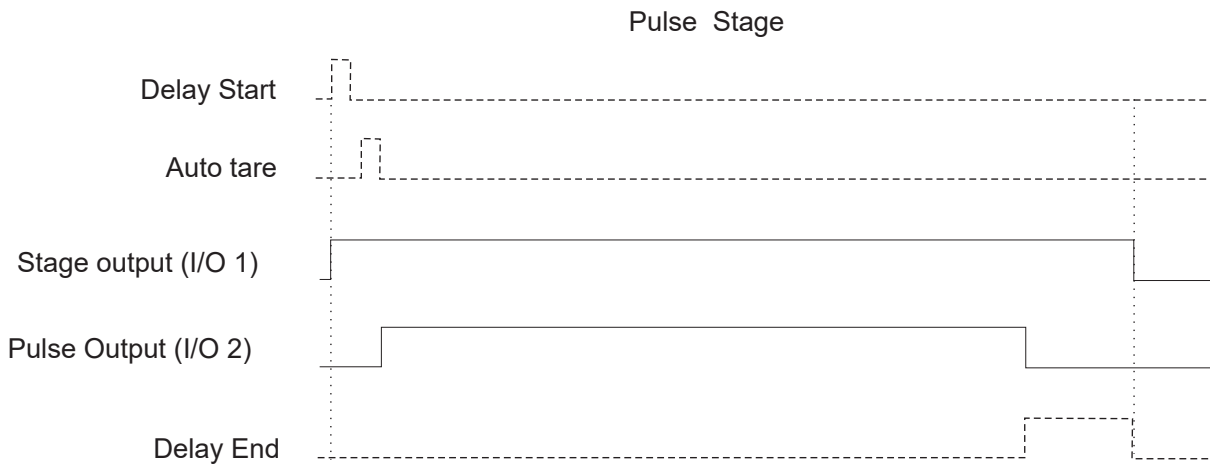

13.4. Batching specific keys

13.4.1. <RECIPE> key - recipe information

- Target: For each fill stage there is a prompt for the target weight.
- Number of Batches: Prompt for the number of batches to run (if used).
- Proportion: The proportion of the batch to make, either as a percentage, ratio, or weight (if used).
- Preset Tare: Value of the preset tare stored for this particular product (if used).
- Start, Repeat, and Stop times: Prompt for the start, repeat and stop times (if used).

The operation of the recipe key is illustrated in 4.6 Recipe page 24.

13.4.2. Timers (6 key) – time duration of PULSE stages

The time duration for any pulse stages is set by the operator with a long press of the 6 key. The operator is prompted to enter the time the pulse output is to be active. The stage number is displayed along with pulse name (if one has been set) to assist the operator in determining which pulse stage is being entered.

Refer to 4.8.6 View and Change Pulse Timers (Timers - 6 key) page 30 for a diagram of the display with this key in use. For the setup menu of a pulse stage refer to 14.9.7 STAGE.n: PULSE page 115.

13.4.3. Flight (8 key) – in-flight and preliminary targets for each material

In-flight compensation is used to force the feeders to shut off early to allow for the amount of material still in flight between the feeder gate and the surface of material already in the weigh-bin.

FLIGHT is the expected weight of material in flight and is initially set by the operator. It applies to the slow fill output.

Within the batching general setup, it is possible to define the number of flight results to be averaged ongoing to improve the in-flight value for the batching process.

For multiple speed applications, preliminary target values are specified for the medium and fast feeders in terms of the 'weight before target'.

M.PRE and **F.PRE** apply to the medium and fast outputs respectively and are set by the operator for each material where multiple feeders are used.

Example: To fill 1000 kg with 800 kg of fast fill, specify the target weight as 1000 kg and the fast preliminary target weight (F.PRE) as 200 kg. This then allows the final target to be changed without the need to change the preliminary targets.

Refer also to 4.8.8 Flight Settings (Flight – 8 key) page 31 for a diagram of the display with this key in use.

13.4.4. Tolerance (9 key) – high and low tolerance for each fill stage

The tolerance weight can be defined for above (TOL.HI) and below (TOL.LO) target for each FILL stage. This tolerance band is used at the end of the FILL stage to check if the final weight is close enough to target.

Within the batching general setup, jogging can be set to jog to either target or to low tolerance (BATCH:GEN:JOG.TGT). The out of tolerance action can be set to either pause or beep (BATCH: GEN:TOL).

Refer also to 4.8.9Tolerance (TOL - 9 key) page 32 for a diagram of the display with this key in use.

13.5. Setpoints

Five (5) batching specific setpoint types are available:

- out of tolerance;
- pause;
- wait;
- run; and
- fill

The allocated output is active when each condition is detected. These are discussed in 11.5 Batching Based Setpoint Types page 68.

13.6. Special Functions

Six (6) batching specific special functions are available and are necessary to control the batching process:

- start;
- pause;
- pause/abort;
- abort;
- suspend; and
- start/pause/abort.

Like the other special functions, these can be allocated to either the three <FUNCTION> keys on the front panel or to the external inputs/outputs. They are discussed in 4.7 Special Functions - Function Keys and External Inputs page 25.

13.7. General Setup

The following criteria are specified for a recipe/product (within BATCH:GEN and BATCH:MAT) and apply to all materials and stages.

Batch start conditions:

- A **start interlock** (ST.ILOCK) when defined, requires the input signal to be present for the batch to commence.
- A **batch interlock** (B.ILOCK) when defined, requires the input signal to be present for the entire batch, otherwise the batch pauses.
- The **zero start** (Z.START) allows for automatic zeroing at the beginning of each batch.
- The **zero interlock** (Z.ILOCK) checks for zero before batching commences, otherwise the batch pauses.

Operator batching criteria:

- The **recipe check** (REC.CHK) option when set to yes, won't allow the batch to start without the recipe being firstly reviewed using the <RECIPE> key. The <RECIPE> prompts the operator for targets, proportions etc.
- The **auto start** (AUTO.ST) option sets if the operator is to specify the number of batches to be run or if a single batch is to run or if an unlimited number of batches should run or if the batch should run at preset intervals based on the clock. The time setting uses the **start** (TM.STRT), **repeat** (TM.RPT) and **stop** (TM.STOP) settings to run multiple batches, these options are set via the <RECIPE> key. The number of batches is set via the <RECIPE> key. **Number clear** (NUM.CL) sets if the number of batches is to be cleared at the end of the run of batches.
- The **proportional type**, (PROP.TP) allows the operator to specify a proportion to batch through a percentage, a ratio, a total batch weight or automatically after the first fill stage. The proportion is set via the <RECIPE> key. **Proportional clear** (PROP.CL) sets if this proportion is to be cleared at the end of a batch or run of batches.
- The **preset tare** (USE.PT) option allows the operator to enter a preset tare for the batch via the <RECIPE> key.

Miscellaneous settings (cannot be changed by the operator):

- **In-flight averaging** (FLT.AV): The number of in-flight results to be averaged is specified in the setup menu BATCH:GEN. If it is greater than five (5) then extreme results are ignored. This averaged in-flight result is used with auto jog and auto flight FILL correction.
- **FILL display** (F.DISP): Determines whether, during a FILL stage, the end weight or the weight left to fill is displayed. Applies across all FILL stages.
- **JOG target** (JOG.TGT): When jogging is being used, this sets if the jogging will be to target or low tolerance. Applies across all FILL stages.
- **Abort Action** (ABT.ACT): sets whether to add to totals or not if the batch is aborted.

- **Batch preference** (B.PREF): sets if speed is more important than accuracy.

Error and out of tolerance handling:

- The **error** (ERROR) option specifies if errors are to be ignored or if the batch is to be paused.
- The **tolerance** (TOL) option specifies what action is to occur when an out of tolerance condition is detected, options are none, pause or beep. The beep option allows for the batch to continue, and pause halts the batch and displays a warning.

Printing batch data:

- The **print** (PRT.OUT) option specifies the printout (PRINT1..2) to be used within the batching process. The printout must be a BATCH type printout. The setup of these printouts is discussed in 10.4 Batch printouts 61.

Storing batch data

- The **DSD use** (DSD.USE) option specifies when data will be written to the DSD if one is fitted.

Materials:

- K410: One (1) material can be specified with an eight (8) character name.
- K411: Six (6) materials can be specified with eight (8) character names.
- K412: Twenty (20) materials can be specified with eight (8) character names.
- The same material can be reused on different stages.

Refer also to 14.9.2 GEN (General) page 109 for the setup menu structure.

13.8. Stage Specific Setup

13.8.1. Outputs

FILL, DUMP and PULSE each allow for the definition of outputs for the given action. FILL allows up to three (3) outputs for three speeds of filling. DUMP and PULSE each have a single output for the dump and pulse signals respectively.

All stage types permit an output to advise the stage ID (STG.OUT). They may be used to advise a PLC of which stage is in progress.

13.8.2. Inputs

Interlock: Interlock inputs can be specified in the setup for the overall batch (batch interlock B.ILOCK), start (start interlock ST.ILOCK) and for FILL and DUMP stages. An interlock is an input signal to demonstrate that a given state exists, for example, is used to indicate that a gate is closed, and it is safe to start filling product.

The batch interlock must be present throughout the entire batch. If the interlock signal is lost the batching process will pause and the Secondary Display will show PAUSE / INTERLOCK.

The start interlock must be present at the commencement of the batch and is checked for each batch when there are multiple auto-starting batches (a number of batches or continuous).

The FILL and DUMP interlock must be present for the duration of the stage. If the interlock signal is lost the batching process will pause and the Secondary Display will show PAUSE / INTERLOCK.

Fill Input: A FILL stage allows an input to be defined for a signal to indicate the end of the fill before the fill target is reached. If the input is specified as NONE the instrument will only end the stage when the fill target is reached. If wait for input (IN.WAIT) is set to ON and an input is specified then the stage will not end until the input is active.

Dump Enable: A DUMP stage allows for a dump enable to be specified. This input is both edge and level sensitive and must be detected for the dump stage to proceed. If enable latch (EN.LTCH) is set to ON the signal may be detected any time after the batch has started and is usually operator initiated, if enable latch is set to OFF then the signal must be detected during the dump stage. It is used to signal to the batching process that it is ok to proceed with the dumping process as conditions downstream are prepared to accept the product.

If no input is assigned to this function it is assumed that the dumping process is cleared to proceed at the commencement of the DUMP stage (not withstanding dump interlock if being used).

Pulse Input: A PULSE stage allows an input to be defined for a signal to indicate the end of the wait. If the input is specified as NONE the instrument will wait for an Operator key (START or OK). If the input is specified as IGNORE then the timer will be used instead.

13.8.3. Delays

For each type of stage it is possible to define a delay either at the start (DLY.ST) or the end (DLY.END) of the stage, of up to 5 hours.

Additionally, a Hold-Off-Check (DLY.CHK) can be set for FILL and DUMP stages, of up to a minute. It stops any weight checks after a decision has been made concerning the outputs. For example, when fast fill changes to slow fill, or when the dump output is first turned on.

13.8.4. FILL Correction (Jogging and In-flight)

The type of correction to be used to get to target can be specified for each FILL stage, using either once off flight or jogging.

In-flight

The slow fill is switched OFF when the weight left to fill equals the in-flight. The in-flight can be set manually or automatically adjusted using past fill results.

The two correction options that use flight only are:

- Manual (MAN.FLT): Uses in-flight as set by operator only.

- Auto Flight (AUT.FLT): Uses the average fill error to calculate a corrected in-flight (as set up in the BATCH:GEN). The amount of averaging is set in BATCH:GEN:FLT.AV. The operator can set a starting in-flight value.

Jogging

If at the end of the normal FILL the weight is still too low, the output is jogged. Jogging is the process of quickly opening and closing a gate to try and adjust the weight to target or the low tolerance depending on setup. To control jogging, ON and OFF times (JOG.ON and JOG.OFF) to drive the output. The repetition rate (JOG.SET) specifies how many 'jogs' are performed before the instrument waits for no motion. The maximum number of jog sets (MAX.SET) if used will limit the number of jog sets performed. If the weight goes over target (regardless of the JOG.SET setting) the jogging will wait for no motion. These are defined for each stage.

The two correction options that use jogging are:

- Jogging (JOG): Jog using in-flight as set by operator.
- Auto Jog (AUT.JOG): Uses the average fill error to calculate a corrected in-flight (as set up in the BATCH:GEN) and jogging. The amount of averaging is set in BATCH:GEN:FLT.AV.

13.8.5. DUMP Correction

A DUMP can be either to weight or time. When it is to weight, it is to the TOL.HI as set in the menu setup for the stage.

A correction of jogging can be chosen to improve accuracy. Jogging is the process of quickly opening and closing a gate to try and adjust the weight to TOL.HI. To control jogging, ON and OFF times (JOG.ON and JOG.OFF) to drive the output. The repetition rate (JOG.SET) specifies how many 'jogs' are performed before the instrument waits for no motion. These are defined for each stage.

13.9. Pause and Abort

A batch can pause automatically for many reasons. It can also be paused by the operator or external input. When the batch is paused, a message is displayed, which describes the reason for the pause. See Pause Conditions page 143. The batch will not abort automatically. The operator can abort a batch using the Abort or Pause/Abort special functions. If printing batch information, an abort message can be printed giving the time of the abort.

13.10. Batching Example

The following example is for a four (4) stage batching process, with two (2) material FILL stages, a PULSE and then a DUMP stage.

- the first fill stage is multi speed with two speeds;
- the second fill stage is a single speed fill only;
- the second fill stage uses jogging for correction, the jogging is jog to target weight and is defined in sets of two;
- there is an automatic zero at the start of the batch and a tare between the fill stages;
- the pulse stage requires an input to end; and

- the dump is a dump to weight.

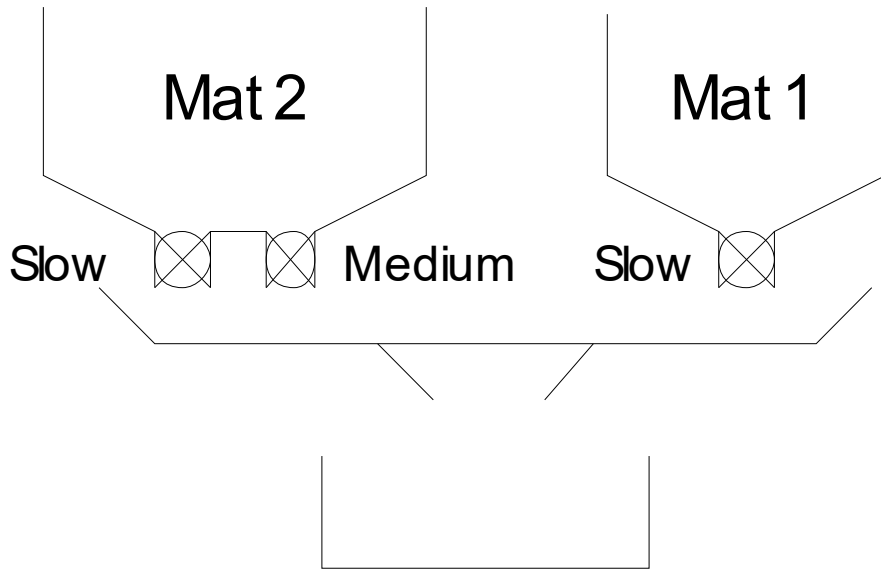

Operator Settings		General Setup
Material 1	Material 2	JOG.TOT = TAR
TARGET = 10 kg	TARGET = 4 kg	Z.START = YES
FLIGHT = 1 kg	FLIGHT = 0.5 kg	
M.PRE = 2 kg		
TOL.HI = 0.01 kg	TOL.HI = 0.01 kg	
TOL.LO = 0.01 kg	TOL.LO = 0.01 kg	

Batching Setup:

Stage 1 – MAT 1	Stage 2 – MAT 2	Stage 3 - PULSE	Stage 4 - DUMP
S.FILL = IO1	S.FILL = IO4	STG.OUT = IO6	STG.OUT = IO8
M.FILL = IO2		INPUT = IO7	DMP.OUT = IO9
ST.ACT = NONE	ST.ACT = TARE	PROMPT = "MIX"	DMP.TYP = WEIGHT
STG.OUT = IO3	STG.OUT = IO5		TOL.HI = 0.01 kg
FEEDER = MULT			
DLY.ST = 0.5 s			
CORR = NONE	CORR = JOG		
MAT = 1	MAT = 2		
	JOG.ON = 0.25s		
	JOG.OFF = 0.25s		
	JOG.SET = 2		

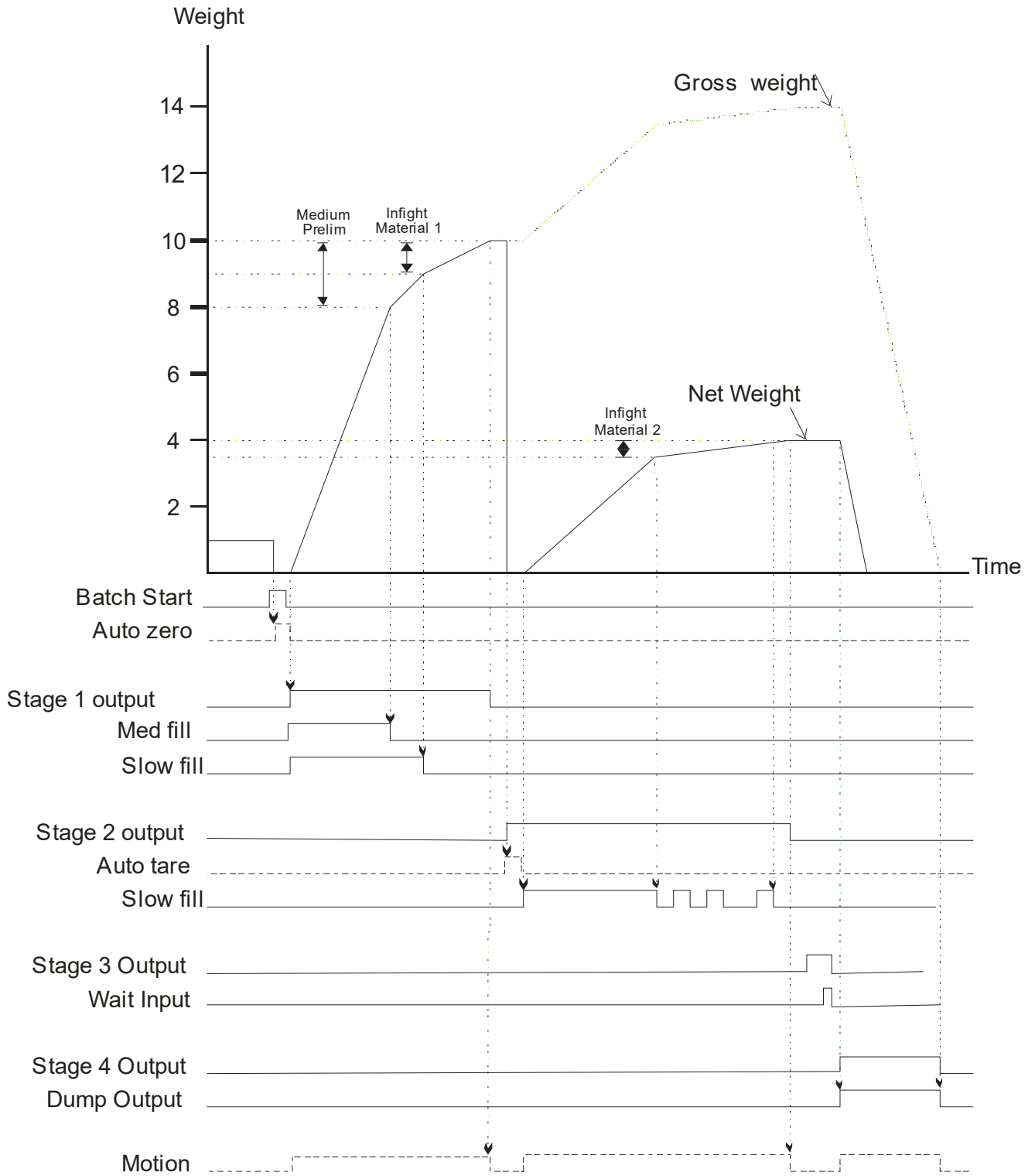

14. Setup Menus

The following sections describe the setup parameters of each of the Groups and Items in Setup. Refer to 5.1 Accessing Full/Safe Setup page 44 for details on accessing setup menus and page 41 for a description on working with the menu structure. A listing of the all the menu items is given in 17 Appendix 4: Setup Menu Quick Reference page 135.

14.1. GEN.OPT (General options)

14.1.1. DATE.F (Date format)

Path	Description
GEN.OPT L DATE.F	Sets the date format
DATE.F Values <OPT>	
DD.MM.YY (Default) , DD.MM.YYYY, MM.DD.YY MM.DD.YYYY, YY.MM.DD, YYYY.MM.DD	

14.1.2. PCODE (Security passcodes)

Refer to 5.2 Passcodes and Key Lock page 40 for further discussion.

Path	Description
GEN.OPT L PCODE L SAFE.PC L FULL.PC (*) L OP.PC	Sets the instrument passcodes. The 3 levels of passcode are: <ul style="list-style-type: none"> • Full passcode (FULL.PC): Controls access to full setup menus. All settings (including trade critical settings) can be altered from full setup. The full passcode will also give access to safe or operator functions. • Safe passcode (SAFE.PC): Controls access to safe setup menus. No trade critical settings can be altered from safe setup. The safe passcode gives access to operator functions as defined by Key Lock. • Operator passcode (OP.PC): Controls access to operator functions, as defined by Key Lock.
(*) Available in FULL SETUP only PCODE Values <NUM> 0 .. 999999 Default: 0 NB: A passcode value of 0 deactivates the passcode.	

14.1.3. KEY.LOC (Key Function Access Control)

Refer to 5.2 Passcodes and Key Lock page 40 for further discussion.

Path	Description
GEN.OPT L KEY.LOC L P (*) L ZERO L TARE L F1 L F2 L F3 L CLOCK L VIEW L REPORT L TOTAL L ID L TARGET L ACC L PR.MOD L PR.SEL L NUM.PAD L ALIBI L RECIPE L FLIGHT L TOL L TIMERS	<p>Access to each of the operator functions can be configured separately.</p> <p>The options are:</p> <p>AVAIL: function always available OPER.PC: requires a valid Operator Passcode SAFE.PC: requires a valid Safe Passcode LOCKED: function never available</p> <p>Functions protected with a 'Safe' passcode prompt for the passcode every time.</p> <p>Entering the Operator Passcode unlocks all operator protected functions, so the operator is not continually prompted for the passcode. In order to lock the instrument again press the '.' key for two seconds (function 'Lock').</p>
KEY.LOC Values <OPT>	
AVAIL ^(Default) , OPER.PC, SAFE.PC, LOCKED (*) AVAIL & LOCKED only are available for POWER.	

14.1.4. DISP (Display options)

Refer to 4.1.1 Display page 20 for an overview.

Path	Description
GEN.OPT L DISP L B.LIGHT L FREQ L AUX.DSP L VIEW	These settings control the operation of the display. B.LIGHT (Backlight operation) FREQ (Frequency) display update rate. AUX.DSP (Auxiliary Display) can be set to OFF, TIME: to show the current instrument time. PRODUCT: shows current product number. STAGE: current batching stage number BAT.NUM: shows current batch number BAT.LEFT: shows remaining number of batches NUM.ITEMS: shows the number of items that have been added to totals
B.LIGHT Values <OPT>	
ON (Default), OFF	
FREQ Values <OPT>	
1, 2, 3.3, 5, 10(Default) Hz	
AUX.DSP Values <OPT>	
OFF(Default), TIME, PRODUCT, STAGE, BAT.NUM, BAT.LEFT, NUM.ITEMS	VIEW (Display Layout) selects the default view displayed when the instrument powers up. The operator can select alternative views by a long press of the '2' key (function 'View').
VIEW Values <OPT>	
PRODUCT (Default), TOP	PRODUCT: information displayed on both displays. TOP: only the Primary Display is shown. The Secondary Display can be used to show operator prompts received from the communications.

14.1.5. ID.NAME (ID name strings)

Refer to 4.8.5 View and Clear ID Names (ID – 5 key) page 29 for discussion on the display.

Path	Description
GEN.OPT L ID.NAME L NAME.1 L NAME.2 L NAME.3 L NAME.4 L NAME.5	ID.NAME is displayed in the Primary Display. There are five IDs available to the operator using a long press of the '5' key (function 'ID'). NAME.1, NAME.2, NAME.3, NAME.4 and NAME.5 specify the actual prompts displayed for the operator. The values that the operator enters are used for printing and other application functions (e.g. to allow the operator to enter a Customer ID, NAME.1 could be set to 'CUST'.)
Values <STR>	
<i>Maximum 6 characters.</i>	To remove an ID from the operator menu give it an empty name.

14.1.6. POWER (Power options)

Refer to 4.2 Power – On/Off page 22 for a description of user operation.

Path	Description
GEN.OPT L POWER L AUT.OFF L START	AUT.OFF (Auto-off delay) Sets the automatic power off setting. The instrument will switch off after set minutes of inactivity. NEVER disables the auto power off feature.
AUT.OFF Values <OPT>	START (Pause at Start-up) If ON the START function forces the instrument to pause on power up and prompt the operator to continue. This ensures that restarting the instrument does not go unnoticed.
NEVER (Default) 5 min 10 min 1 min 60 min	
START Values <OPT>	
OFF (Default), ON	

14.1.7. STR.EDT (String editor default mode)

Path	Description
GEN.OPT L STR.EDT	Sets the mode that the string editor will start in.
STR.EDT Values <OPT>	
<ul style="list-style-type: none"> • AUTO (Default) • STRING • NUM 	

14.1.8. USR.DEF (Set all non-calibration settings to defaults)

Path	Description
GEN.OPT L USER.DEF	Sets all general instrument settings to defaults. This will not affect settings in the SCALE menu which includes all calibration and configuration settings.
Values	
DEFAULT? <OK> CONFIRM? <OK>	

14.2. H.WARE (Hardware Configuration & Test)

14.2.1. LC.HW

Path	Description
H.WARE L LC.HW L MVV L OL.CNT L OL.CLR	MVV View Load cell mV/V reading. OL.CNT (Overload count) Shows the number of times the instrument has been overloaded or underloaded by at least 50% of fullscale.

	OL.CLR (Overload clear) Clear the overload counter.
--	---

14.2.2. SER1.HW, SER2.HW

Path	Description
H.WARE	BAUD (Baud Rate)
L SER1.HW	Sets the baud rate for the port.
L BAUD	
L PARITY	PARITY
L DATA	Sets the parity for the port.
L STOP	
L DTR	DATA (Data bits)
L TERM	Sets the number of data bits for the port.
L SER2.HW	STOP (Stop bits)
L BAUD	Sets the number of stop bits for the port.
L PARITY	
L DATA	DTR (DTR usage)
L STOP	Use the DTR line with RS232 printing.
L DTR	TERM (Termination Resistors)
L TERM	Use termination resistors with RS485.
L RING	RING (Ring network)
	Enable ring network. Only available on SER2 and requires M42xx software version 1.01+.
BAUD Values <OPT>	
1200 , _2400_ , _4800_ , _9600_ (Default) , _19200_ , _57600_	
PARITY Values <OPT>	
NONE (Default) , EVEN , ODD	
DATA Values <OPT>	
8 (Default) , _7_	
STOP Values <OPT>	
1 (Default) , _2_	
DTR Values <OPT>	
OFF (Default) , ON	
TERM Values <OPT>	
OFF (Default) , ON	
RING Values <OPT>	
OFF (Default) , ON	

14.2.3. IO.HW

Path	Description
H.WARE └ IO.HW └ FRC.OUT └ TST.IN └ DB.1.8 └ DBNC.1 : └ DBNC.8 └ DB.9.16 └ DBNC.9 : └ DBNC.16 └ DB.17.24 └ DBNC.17 : └ DBNC.24 └ DB.25.32 └ DBNC.25 : └ DBNC.32	<p>FRC.OUT (Force Outputs)</p> <p>Use this when testing and fault finding to force the IO on and off. Use the UP and DOWN keys to select the output. Use the +/- key to switch the output on and off.</p> <p>TST.IN (Test Inputs)</p> <p>Use this when testing and fault finding to check the status of IO when used as inputs. Inputs are listed for each module in order of lowest to highest IO number. '1' means the input is active, '0' means the input is inactive. Use the UP and DOWN keys to select the module to view.</p> <p>DBNC (Debounce)</p> <p>This sets the amount of debouncing for inputs. It is set in milliseconds [ms].</p>
<p>DBNC Values <NUM></p>	
<p>1..250 ms Default: 50 ms</p>	

14.2.4. ANL.HW

Refer to 12 Analogue Output page 72 for further discussion.

Path	Description
H.WARE L ANL.HW L TYPE L CLIP L FRC.OUT L ANL.CAL L ADJ.LO L ADJ.HI	TYPE (Analogue Output Type) - Sets the analogue output to current (4-20mA) or voltage (0-10V) mode. CLIP (Analogue Output Clip Enable) - When clipping is on, the output is restricted to 4-20mA or 0-10V. When clipping is off, the output can go at least 3mA or 0.5V beyond these limits. FRC.OUT (Force Analogue Output) - Sets the number of data bits for the port. ADJ.LO (Calibrate Analogue Output) - Calibrate 4mA or 0V analogue output. Use the UP and DOWN keys to adjust the calibration. ADJ.HI (Calibrate Analogue Output) - Adjust 20mA or 10V analogue output. Use the UP and DOWN keys to adjust the calibration.
TYPE Values <OPT>	
Current ^(Default) , Volt	
CLIP Values <OPT>	
NO ^(Default) , YES	

14.2.5. DSD.HW

Path	Description
H.WARE L DSD.HW L AUTO.C L DSD.STR	AUTO.C (Auto Clear) Sets whether the DSD will automatically write over the oldest records when it becomes full. DSD.STR (DSD String) Custom string to be stored along with the traceable data when the DSD is written. This accepts all print tokens.
AUTO.C Values <OPT>	
OFF, ON ^(Default)	
DSD.STR Values <STR>	
<i>Maximum 20 characters.</i>	

14.2.6. ETH.HW

Path	Description
H.WARE L ETH.HW L DHCP L IP L NET.MSK L G.WAY L DNS.1 L DNS.2	DHCP (Dynamic Host Configuration Protocol) Enables or disables the use of DHCP to configure the IP settings of the M4221 Ethernet module. To use this option requires a DHCP server on the network. IP (Internet Protocol Address) Sets the IP address for the M4221 Ethernet module. NET.MSK (Network Mask) Sets the network mask the M4221. This defines
DHCP Values <OPT>	
ON ^(Default) , OFF	
Note: IP, NET.MSK, G.WAY,	

<p>DNS.1, DNS.2 settings are not available when DHCP is ON.</p>	<p>the proportion of the IP address bits that reside on the M4221's subnet.</p> <p>G.WAY (Default Gateway)</p> <p>Sets the default gateway for the M4221. This is the server through which traffic destined for hosts beyond the M4221's subnet is routed.</p> <p>DNS.1 (Primary Domain Name Server)</p> <p>Sets the primary domain name server for the M4221. If not required use 0.0.0.0.</p> <p>DNS.2 (Secondary Domain Name Server)</p> <p>Sets the secondary domain name server for the M4221. If not required use 0.0.0.0.</p>
---	---

14.2.7. ETH.DEF (Set the M4221 Ethernet module to defaults)

Path	Description
<p>H.WARE └ ETH.HW └ ETH.DEF</p>	<p>Sets all settings stored within the M4221 Ethernet module to defaults.</p> <p>This will not affect any instrument settings.</p>
Values	
<p>DEFAULT? <OK> CONFIRM? <OK></p>	

14.3. SCALE (Load cell options and calibration)

14.3.1. BUILD (Scale parameters)

Refer also to 6.1 Scale Parameters (SCALE:BUILD) page 44 for further discussion and 3.8 Load Cell Connection page 10.

Path	Description
SCALE	Scale Base configuration settings:
L BUILD	TYPE: Range type. Options are:
L TYPE	<ul style="list-style-type: none"> • SINGLE: Single range • DUAL.I: Dual interval • DUAL.R: Dual range
L CABLE	CABLE: 6-wire or 4-wire cable termination:
L DP	<ul style="list-style-type: none"> • 6-wire: SENSE lines are connected to the instrument. • 4-wire: Internal connection between Excitation and SENSE lines is active.
L CAP1	DP: Set the decimal point position.
L E1	CAP1: Sets the fullscale capacity for the scale. If using multiple interval/range, this sets the fullscale capacity of the lowest range/interval.
L CAP2(*)	E1: Sets the count-by (or resolution) of the scale. If using multiple interval/range, this sets the count-by (or resolution) of the lowest range/interval.
L E2(*)	CAP2: If using multiple interval/range, this sets the fullscale capacity of the highest range/interval.
L UNITS	E2: If using multiple interval/range, this sets the count-by (or resolution) of the highest range/interval.
L HI.RES	UNITS: Sets the weighing units.
TYPE Values <OPT>	NB: For Options:
SINGLE (Default)	<ul style="list-style-type: none"> • None: Units are left blank.
DUAL.I , DUAL.R	ARROW.U: Use the top arrow. Units will be printed onto the instrument in the correct location.
CABLE Values <OPT>	HI.RES: Sets the scale to high resolution (x10) mode.
6 WIRE (Default) , 4 WIRE	
DP Values <OPT>	
000000 (Default)	000.000
00000.0	00.0000
0000.00	0.00000
CAP1 & CAP2 Values <NUM>	
100..999999	
Default: 3000	
NB: Numbers above assume no decimal point.	
E1 & E2 Values <OPT>	
1(Default) , 2, 5, 10, 20, 50, 100	
UNITS Values <OPT>	
None	Oz
kg (Default)	N
lb	ARROW U
t	P
g	
HI.RES Values <OPT>	
OFF (Default) , ON	

14.3.2. OPTION (Scale options)

Refer also to 6.2 Scale Options (SCALE:OPTIONS) page 45 for further discussion.

Path	Description
SCALE	<p>USE (Trade Use): This setting affects the operation of trade functions. Options are:</p> <ul style="list-style-type: none"> • INDUST: Industrial (no standard) • OIML: OIML trade mode • NTEP: NTEP trade mode <p>FILTER: Set the number of seconds of digital filtering.</p> <p>MOTION: Sets the motion detection sensitivity. This setting is given as $xd - yt$ where weight change of more than x divisions in y seconds will trigger motion.</p> <p>Z.RANGE (Range of Zero): Sets the range over which the indicator can zero the scale.</p> <p>Z.TRAC (Zero Tracking): Sets the rate of automatic zero tracking. Slow is 2Hz, Fast is 10Hz.</p> <p>Z.INIT (Zero on Startup): Enables the zero-on-start-up feature. When enabled, a zero will be performed as part of the instrument start-up procedure.</p> <p>Z.BAND (Zero Deadband): Sets the weight range around zero which will be considered zero for application purposes.</p> <p>EXT.EX (External Excitation): If using an external supply for load cell excitation this setting enables additional background calibration services. Under normal conditions this feature is not required. The excitation must be 5V – 8V.</p> <p>R.ENTRY (Rear Entry): Full access via the rear setup button only. This option is only available when the rear setup button has been used to access the menu system</p> <p>TOT.OPT (Totalising Option): Type of weight used with totalising. Gross or net weight should be used if gross and net weights cannot be added into a single total.</p>
L OPTION	
L USE	
L FILTER	
L MOTION	
L Z.RANGE	
L Z.TRACK	
L Z.INIT	
L Z.BAND	
L EXT.EX	
L R.ENTRY	
L TOT.OPT	
USE Values <OPT>	
INDUST (Default)	
OIML, NTEP	
FILTER Values <NUM>	
0.01s..30.00s <i>Default: 0.5s</i>	
MOTION Values <OPT>	
0.5d – 1.0t (Default)	2.0d – 0.5t
1.0d – 1.0t	5.0d – 0.5t
2.0d – 1.0t	0.5d – 0.2t
5.0d – 1.0t	1.0d – 0.2t
0.5d – 0.5t	2.0d – 0.2t
1.0d – 0.5t	5.0d – 0.2t
Z.RANGE Values <OPT>	
-2 .. 2 (Default) , -1 .. 3, -10 .. 10, -20 .. 20	
Z.TRACK Values <OPT>	
Off (Default), Slow, Fast	
Z.INIT Values <OPT>	
Off (Default) , On	
Z.BAND Values <NUM>	
0 – fullscale <i>Default: 0</i>	
EXT.EX Values <OPT>	
Off (Default) , On	
R.ENTRY Values <OPT>	
Off (Default) , On	
TOT.OPT Values <OPT>	

Disp (Default), Gross, Net

14.3.3. CAL (Scale calibration)

Refer also to 7 Calibration (SCALE:CAL page 46 for further discussion.

Path	Description
SCALE	Calibrate Scale
└ CAL	ZERO: Perform a zero calibration.
└ ZERO	SPAN: Perform a span calibration. A zero calibration should be done before doing a span calibration.
└ SPAN	ED.LIN: Add or Modify linearisation points.
└ ED.LIN	CLR.LIN: Clear unwanted linearisation points.
└ CLR.LIN	DIR.ZER (Direct mV/V Zero Calibration): Enter signal strength (in mV/V) of zero calibration directly.
└ DIR.ZERO	DIR.SPN (direct mV/V span Calibration): Enter the signal strength (in mV/V) of full scale directly. No test weights required.
└ DIR.SPN	DEF.CAL (Default Calibration): Restore instrument to default factory calibration.
└ DEF.CAL	

14.3.4. QA (QA alarm)

Path	Description
SCALE:	Configure the quality assurance feature.
└ QA	If active the instrument displays a 'QA DUE' warning after the date limit has expired.
└ QA.OPT	QA.OPT: Turn QA feature on or off.
└ QA.YEAR	QA.YEAR, QA.MONTH, QA.DAY: Enter QA expiry date.
└ QA.MONTH	
└ QA.DAY	
QA.OPT Values <OPT>	
Off (Default), On	
QA.DATE Values <NUM>	
2000-01-01 to 2099-12-31	

14.4. FUNC (Special functions)

Special Functions - Function Keys and External Inputs page 25.

14.4.1. NUM (Number of special functions)

Path	Description
FUNC L NUM	Sets the number of special functions.
NUM Values <OPT>	
-1- (Default) .. -8-	

14.4.2. SFn: TYPE (Function Types)

Path	Description
FUNC L SFn LTYPE	Sets the type of special function assigned to be assigned to the key. Options are: PRINT: Print defined record printout. SINGLE: Trigger a single serial weight transmission TEST: Display test PRD.SEL: Select Product/Recipe (currently one) REM.KEY: Remote Key operation BLANK: Blanking input THUMB: Thumb-wheel product selection START: Start batch PAUSE: Pause batching; To resume batching press START key again. ABORT: Abort batching PSE.ABT: Long press to abort current batch. To resume batching press START key again. ST.PS.AB: Long press to abort current batch. Short press to toggle between pause/start. SUSPND: suspend batching REPORT: Print report.
TYPE Values <OPT>	
NONE (Default) PRINT SINGLE TEST PRD.SEL REM.KEY BLANK THUMB START PAUSE ABORT PSE.ABT ST.PS.AB SUSPND REPORT	

14.4.3. SFn: KEY (Function Key / Remote Input)

Path	Description
FUNC L SFn L KEY	Select front panel key or external input to trigger the special function. All functions that respond to input events have a KEY setting. Functions like THUMB (Thumbwheel) require multiple inputs to function and have an equivalent setting to specify these inputs.
KEY Values <OPT>	
None (Default) F1 .. F3 IO1 .. IO32	

14.4.4. SFn: PRINT (Printing Functions)

Path	Description
FUNC L SFn L TYPE : PRINT L KEY L LONG.PR L PRT.OUT L IL.TYPE L I.LOCK	Configuration of the PRINT Special Function. KEY: Select key (function key or external input) to be used for this special function. LONG.PR (LONG PRESS): Selects if long press functionality should be enabled. PRT.OUT (Printout): Selects the printout to be used. Up to two printouts can be configured in the PRINT menu and one selected here, only RECORD type printouts are valid. IL.TYPE (Interlock Type): Sets the type of printing interlock to be used. Options are: <ul style="list-style-type: none"> • MOTION: Printing is enabled every time the scale becomes stable. • I.LOCK: Printing is enabled when the weight is stable after a weight movement larger than the interlock weight. • RET.Z: Printing is enabled after the scale has returned to zero and is stable at a reading other than zero.
KEY Values <OPT>	
None (Default), F1 .. F3, IO1 .. IO32	
PRT.OUT Values <OPT>	
None (Default), PRINT.1 .. PRINT.2	
IL.TYPE Values <OPT>	
NONE (Default), MOTION I.LOCK, RET.Z	
I.LOCK Values <NUM>	
0 .. Fullscale	I.LOCK (Interlock): Sets the interlock weight that will trigger a print event.

14.4.5. SFn: SINGLE (Single Serial Output Functions)

Path	Description
FUNC L SFn L TYPE : SINGLE L KEY L AUT.OUT	Single serial outputs are similar to printing but do not support any interlocking or totalising functions. KEY: Function key or external input to use. AUT.OUT: Choose which Auto Output Serial service to trigger. The Auto Output TYPE should be set to SINGLE.
KEY Values <OPT>	
None (Default), F1 .. F3, IO1 .. IO32	
AUT.OUT Values <OPT>	
AUTO.1 (Default), AUTO.2	

14.4.6. SFn: BLANK (Blanking Functions)

Path	Description
FUNC L SFn L TYPE : BLANK L KEY L BLANK	Blanking functions enable the detection of external inputs to be used to block instrument operation by blanking the screen and blocking key functions. Typical applications are for tilt sensing.

KEY Values <OPT>	KEY: External input to use.
None (Default), F1 .. F3, IO1 .. IO32	
BLANK Values <OPT>	BLANK: Set display blanking style. Options are: <ul style="list-style-type: none"> • DASH: Fill instrument display with ‘-‘ characters. • BLANK: completely blank instrument display.
DASH (Default), BLANK	

14.4.7. SFn: START, SFn: PAUSE, SFn:ABORT, SFn PSE.ABT, ST.PS.AB, SFn: SUSPND (Batching Functions)

Path	Description
FUNC L SFn L TYPE:START, PAUSE,ABORT, PSE.ABT, ST.PS.AB SUSPND L KEY	Batching control functions. KEY: Select key or external input to use for this special function.
KEY Values <OPT>	
None (Default), F1 .. F3, IO1 .. IO32	

14.4.8. SFn: THUMB (Thumbwheel Product Selection)

Path	Description
FUNC L SF _n LTYPE : THUMB L IO.BAND	The Thumbwheel function supports the use of an external thumbwheel to select the current product using the product number. A selection of '0' on the thumbwheel enables keyboard selection of the current product.
IO.BAND Values <OPT>	IO.BAND: Select which four remote inputs are used for the thumbwheel function.
IO1-4 ^(Default) , IO17-20,	
IO5-8, IO21-24,	
IO9-12, IO25-28,	
IO13-16, IO29-32	

14.4.9. SFn: REM.KEY (Remote Key Functions)

Path	Description
FUNC L SF _n LTYPE : REM.KEY L KEY L FUNC	Remote key functions allow external inputs to be used to trigger instrument key functions. The external 'keys' operate even if the instrument keys are locked and never require Operator or Setup passcodes to be entered.
KEY Values <OPT>	KEY: External input to use. FUNC: Choose the keyboard function to be assigned to the remote key.
None ^(Default) , IO1 .. IO32	
FUNC Values <OPT>	
NONE, ZERO, TARE, _0_, _1_, _2_,...	

14.4.10. SFn: REPORT (Report Functions) :

Path	Description
FUNC L SFn L TYPE : REPORT L KEY L PRT.OUT L CLR.TOT	Configuration of the REPORT Special Function. KEY: Select key (function key or external input) to be used for this special function. PRT.OUT (Printout): Selects the printout to be used. Up to two printouts can be configured in the PRINT menu and one selected here, only REPORT type printouts are valid. CLR.TOT (Clear Totals): Sets whether totals are cleared automatically after print.
KEY Values <OPT>	
None (Default), F1 .. F3, IO1 .. IO32	
PRT.OUT Values <OPT>	
None (Default), PRINT.1 .. PRINT.2	
CLR.TOT Values <OPT>	
NO (Default), ASK, CLEAR	

14.5. SER.NET (Network communications)

Refer also to 8 Network page 51.

Path	Description
SER.NET L ADDR L NUM L NET.n L TYPE L SERIAL L SOURCE (*)	Configure the serial networking support. ADDR (Address): Address of instrument (1..31). NUM (Number): Number of Networks (1 or 2). TYPE: Type of Network Protocol: <ul style="list-style-type: none"> • NONE: Disable networking. • RINCMD: See Network page 51. • BARCODE: See Network page 51.
ADDR Values <NUM>	
1(Default)..31	
NUM Values <OPT>	
1 .. 2 (Default)	
TYPE Values <OPT>	
NONE, RINCMD(Default), BARCODE	
SERIAL Values <OPT>	
SER1A(Default), SER2A, SER3A	
SOURCE Values <OPT>	
NAME(Default), BCODE, ID (*)NB: Only available in BARCODE Type	SERIAL: Serial Port to use. SOURCE: Barcode protocol source, settable to product name (NAME), product barcode (B.CODE) or product ID (ID).

14.6. SER.AUT (Automatic transmit)

Refer also to 9 Automatic Weight Output page 58.

14.6.1. NUM (Number of Automatic Transmissions)

Path	Description
SER.AUT L NUM	Sets the number of special automatic outputs
Values <OPT>	
-1- (Default) .. -2-	

14.6.2. AUTO.n (Automatic Output Configuration)

Path	Description
SER.AUT L AUTO.n L TYPE L SERIAL L FORMAT L SOURCE L EV.AUTO(*)	These settings are the same for AUTO.1 and AUTO.2
TYPE Values <OPT>	
NONE (Default) SINGLE AUTO.LO	AUTO.HI AUT.TRC 5 HZ
SERIAL Values <OPT>	
SER1A (Default), SER1B SER2A, SER2B, SER3A, SER 3B	
FORMAT Values <OPT>	
FMT.A (Default) FMT.B FMT.C FMT.D	FMT.E FMT.REG FMT.TRC CUSTOM FMT.G
SOURCE Values <OPT>	
GROSS (Default), NET GR.or.NT	
EV.AUTO Values <STR>	
Token String (*) Only used with CUSTOM format.	

TYPE: Sets the transmission rate. Options are:

- SINGLE: A SINGLE function key is used to trigger a single transmission. Rate is determined by external input.
- AUTO.LO: Transmit at 10Hz frequency
- AUTO.HI: Transmit at 25Hz frequency
- AUT.TRC: Sends a message for every traceable weight
- 5 HZ: Transmit at 5Hz frequency

SERIAL: Select Serial port to use.

FORMAT: Set data format. See Auto Weight Format String page 58.

SOURCE: Sets the weight data to send:

- GROSS: Gross weight
- Net: Net weight
- Gr.or.Nt: Gross or net weight

EV.AUTO: Token string to define data format for CUSTOM transmissions.

14.7. PRINT (Printouts)

14.7.1. NUM (Number of printouts)

Path	Description
PRINT L NUM	Sets the number of printouts.
Values <OPT>	
1 (Default) .. _2_	

14.7.2. HEADER (Print header)

Path	Description
PRINT L HEADER	Sets the print header.
Values <STR>	
String	

14.7.3. FOOTER (Print footer)

Path	Description
PRINT L FOOTER	Sets the print footer.
Values <STR>	
String	

14.7.4. PAGE (Print page options)

Path	Description
PRINT L PAGE L WIDTH L HEIGHT L PG.END	Page settings configure the height and width of the paper and what to do at the bottom of a page. WIDTH: Sets the page width. A setting of zero disables page width checking. HEIGHT: Sets the page height. A setting of zero disables page height checking.
WIDTH Values <NUM>	
0 .. 250 <i>Default: 0</i>	
HEIGHT Values <NUM>	
0 .. 250 <i>Default: 0</i>	
PG.END Values <STR>	PG.END (Page End String): Sets the string to print at page end. This option allows a cut character, form feed, etc, to be added every page.
Token String	

14.7.5. SPACE (Print blank space options)

Path	Description
PRINT L SPACE L TOP L LEFT L BOTTOM	Space controls the amount of white space to leave around the printout. TOP: Sets the number of blank lines to add at the top of each page. LEFT: Sets the number of spaces to add at the beginning of each line.
Values <NUM>	BOTTOM: Sets the number of blank lines to add to the bottom of each page.
0 .. 10 <i>Default: 0</i>	

14.7.6. PRINT.n ... (Printout options)

Refer to section 10 Printing page 60 for further discussion on printing.

Path	Description
PRINT L PRINT.n L TYPE L FORMAT L SERIAL L NAME L CUSTOM * L REC.PRN or L SER.ST** L SER.END** L BAT.ST L BAT.END L FILL L DUMP L PULSE L ABORT or L REP.ST L REP.PR L REP.MAT L REP.END	Each printout has its own format settings. TYPE: Sets the printout type. RECORD is used to print weight at an instance BATCH used within or at the end of the batching process to report on batching and material totals against targets. REPORT used to print data on grand totals (since they were last cleared). FORMAT: Sets the printout format. SERIAL: Select Serial port to use. NAME (Printout Name): Report printouts are available by name to the operator. CUSTOM: For custom printing, each type of printout uses event strings as follows: RECORD: REC.PRN (Record Print): defines entire printout. BATCH: BAT.ST (Event Batch Start) defines what is printed at the start of a batch. BAT.END (Event Batch End) defines what is printed at the end of a batch. FILL (Event Fill Stage) defines what is printed at end of a fill stage. DUMP (Event Dump Stage) defines what is printed at end of a dump stage. PULSE (Event Pulse Stage) defines what is printed for a pulse stage ABORT (Event Abort) defines what is printed when a batch is aborted. SER.ST ** (Event Series Start) defines what is printed at the start of a series of batches. SER.END ** (Event Series End) defines what is printed at the end of a series of batches. REPORT: REP.ST (Report Start) defines start of report. REP.PR (Report Product) controls the information printed for each product/recipe (currently only one). REP.MAT (Report Material) defined information printed for each material. REP.END (Report End) defines the end of the report.
TYPE Values <OPT>	
NONE (Default), RECORD, BATCH, REPORT	
FORMAT Values <OPT>	
FMT.A (Default), FMT.B CUSTOM	
SERIAL Values <OPT>	
SER1A (Default), SER2A, SER1B, SER2B, SER3A, SER3B	
NAME Values <STR>	
6-character String	
CUSTOM Values <STR>	
* Active token strings depend on the TYPE setting ** Only available when a number of batches are being run.	

14.8. SETP (Setpoints)

Refer to 11 Setpoints page 65 for discussion on setpoints.

14.8.1. NUM (Number of setpoints)

Path	Description
SETP └ NUM	Sets the number of setpoints
Values <OPT>	
1 ... _8_ (Default)	

14.8.2. SETP1 ... SETP8 (Setpoint options)

Path	Description
SETP └ SETP _n └ TYPE └ OUTPUT └ LOGIC └ ALARM └ SOURCE(*) └ SCOPE(**) └ HYS(**) └ MASK(***) └ DELAY(****) └ ON(****) └ TIMING └ RESET └ PLS.NUM(****) └ RST.LGC └ DLY.ON(***) └ HLD.OFF(***) └ NAME	<p>Configure the operation of each setpoint.</p> <p>TYPE determines the function of the setpoint. Options are:</p> <p>NONE: Always inactive ON: Always active OVER: active if weight over target UNDER: active if weight under target COZ: active if Centre of Zero ZERO: active if weight is zero NET: active if net weight selected MOTION: active if weight unstable ERROR: active if error conditions detected LGC.AND: active if inputs match the bits set in the mask exactly LGC.OR: active if any inputs match the bits set in the mask LGC.XOR: active if only one input matches the bits set in the mask TOL: active if out of tolerance PAUSE: active if batch paused WAIT: active if batch waiting for dump enable input RUN: active while batch is running (including when batch is paused) FILL: active whenever any filling stage is running BUZZER: active when the buzzer sounds.</p> <p>OUTPUT specifies which IO to use or the setpoint output.</p> <p>LOGIC: Logic HIGH forces the output to follow the setpoint activity. Logic LOW forces the output to the reverse of the setpoint activity.</p> <p>ALARM: Alarms are triggered when the setpoint is active. Options are:</p> <p>NONE: no alarm SINGLE: single BEEP</p>
TYPE Values <OPT>	
<ul style="list-style-type: none"> • NONE (Default) • ON • OVER • UNDER • COZ • ZERO • NET • MOTION • ERROR • LGC.AND • LGC.OR • LGC.XOR • TOL • PAUSE • WAIT • RUN • FILL • BUZZER 	

OUTPUT Values <OPT>		DOUBLE: double BEEP
NONE, IO1 .. IO32 (Default)		FLASH: flash display
LOGIC Values <OPT>		SOURCE: Select which weight values the setpoint checks against the target weight. Options are:
HIGH (Default), LOW		GROSS: Gross weight always
ALARM Values <OPT>		NET: Net weight always
NONE (Default)	DOUBLE	GR.or.NT: Gross or Net depending on which one is displayed.
SINGLE	FLASH	SCOPE: The setpoint target can be set to be identical for all products (GLOBAL) or different for each product (PROD).
SOURCE Values <OPT>		HYS: Hysteresis defines the amount of weight required for an active setpoint to become inactive again. A value of 0 still allows for 0.5 graduations of hysteresis.
GROSS (Default), NET, GR.or.NT		MASK: A 32 bit number that is used by the logic setpoints to match IO1 .. IO32
(*) NB: Only available in OVER, UNDER, ZERO		DELAY: If the timing has been set to PULSE this sets the delay before each pulse.
IO(Default), STATUS, SETP, REG		ON: If the timing has been set to PULSE this sets the duration of each pulse.
(*) NB: Only available in LGC.AND, LGC.OR, and LGC.XOR setpoints.		TIMING: Select the timing which is applied to the setpoint output. Options are:
SCOPE Values <OPT>		LEVEL: Setpoint follows the weight.
GLOBAL (Default), PROD		EDGE: Setpoint is edge triggered.
(**) NB: Only available in v2.x software for OVER and UNDER setpoints		PULSE: Setpoint output is pulsed.
HYS Values <NUM>		LATCH: Setpoint output is latched.
0 to 999999 <i>Default: 0</i>		RESET: Select which IO is used as an input to disable the setpoint. Options are NONE, IO1..IO32
(**) NB: Only for OVER, and UNDER setpoints.		PLS.NUM: If the timing has been set to PULSE this sets the number of pulses to be output each time the setpoint is triggered.
MASK Values <NUM>		RST.LGC: This setting determines whether the input used to reset the setpoint is active when the value is LOW or HIGH.
0 to 4294967295 <i>Default 0</i>		DLY.ON: Delay for logic setpoints before setpoint becomes active.
(***) NB: Only for LGC.AND, LGC.OR and LGC.XOR setpoints		HLD.OFF: Delay for logic setpoints before setpoint becomes inactive.
DELAY Values <NUM>		NAME: give the setpoint a name, this will be shown when editing targets.
0.040 to 60.000s <i>Default: 0.040s</i>		
(***) NB: Only for PULSE TIMING setpoint.		
ON Values <NUM>		
0.040 to 60.000s <i>Default: 0.040s</i>		
(***) NB: Only for PULSE TIMING setpoint.		
TIMING Values <OPT>		
LEVEL (Default), EDGE, PULSE, LATCH		

RESET Values <OPT>	NONE ^(Default) , IO1..32
PLS.NUM Values <NUM>	1 to 20 <i>Default 1</i> (***) NB: Only for PULSE TIMING setpoint.
RST.LGC Values <OPT>	HIGH ^(Default) , LOW
DLY.ON Values <NUM>	0.00 to 600.00s <i>Default: 0s</i> (***) NB: Only for LGC.AND, LGC.OR and LGC.XOR setpoints
HLD.OFF Values <NUM>	0.00 to 600.00s <i>Default: 0s</i> (***) NB: Only for LGC.AND, LGC.OR and LGC.XOR setpoints
NAME Values <STR>	6-character String

14.9. BATCH

Batching is also discussed in 13 Batching page 73, along with timing diagrams.

14.9.1. APP (Applications) (K411 and K412 only)

Path	Description
BATCH L APP	Set of predefined batching configurations for initial menu setup. The options vary the number of materials (FILL stages) and speeds.
APP Values <OPT>	Choose an option closest to the application to be programmed and vary settings as required.
1MAT.1SPD, 1MAT.2SPD, 1MAT.3 SPD,	FILL stages are preset using multiple feeders and auto-flight correction.
2MAT.1SPD, 2MAT.2SPD, 2MAT.3SPD,	Each application has a DUMP stage.
...	Extra stages can be inserted or deleted as required.
6MAT.1SPD, 6MAT.2SPD, 6MAT.3SPD	1MAT.1SPD – 1 material, 1 speed uses one single speed FILL stage and one DUMP stage.
	1MAT.2SPD – 1 material, 2 speed uses one FILL stage with two speeds and one DUMP stage.
	6MAT.3SPD – 6 materials, 3 speed uses six FILL stages each with three speeds and one DUMP stage.

14.9.2. GEN (General)

Path	Description
BATCH	Start Interlock (ST.ILOCK): Input for start interlock if being used (distinct from FILL stage interlock). If used, batch will not start without this input active.
L GEN	
L ST.ILOCK	
L B.ILOCK	Batch Interlock (B.ILOCK): Input for batch. This input must be on for batching to proceed. If not present, the batch is paused automatically.
L Z.START	Zero on Start (Z.START): YES – forces automatic zero at start of the batch.
L Z.ILOCK	Zero Interlock (Z.ILOCK): YES – batch PAUSE.ERROR created if not zero at start of batch. This can be used in conjunction with Z.START.
L REC.CHK	Recipe Check (REC.CHK): YES - START key does not operate unless RECIPE key is pressed first.
L AUTO.ST	Auto Start (AUTO.ST):
L NUM.CL	SINGLE: Single batch only
L PROP.TP	CONT: Continuous restart until PAUSE or ABORT by Operator
L PROP.CL	NUM: To allow Operator to specify number of batches through RECIPE key.
L USE.PT	TIME: batch from start time (TM.STRT) at repeat time (TM.RPT) interval until the stop time (TM.STOP), time settings are set through the RECIPE key. If start and stop times are set to the same values the indicator will batch continuously at the repeat time intervals.
L FLT.AV	
L F.DISP	
L JOG.TGT	
L ABT.ACT	
L ERROR	
L TOL	
L PRT.OUT	
L DSD.USE	
L B.PREF	
ST.ILOCK Values <OPT>	
NONE ^(Default) , IO1 .. IO32	Auto-clear Number Batches (NUM.CL): YES automatically clears number of batches at the end of the run of multiple batches.
B.ILOCK Values <OPT>	
NONE ^(Default) , IO1 .. IO32	Proportional Control (PROP.TP): This control only affects targets, not in-flight/prelims.
Z.START Values <OPT>	Percentage (PC): 5% to 2000%,
YES, NO ^(Default)	Proportion (PROP): 0.050 to 20.000
Z.ILOCK Values <OPT>	Total (TOTAL): Total batch weight.
YES, NO ^(Default)	Auto (AUTO): Automatically recalculate proportion after first fill stage.
REC.CHK Values <OPT>	Auto-clear Proportion (PROP.CL):
YES, NO ^(Default)	YES - Automatically clears proportion to 100% at the end of the batch, or the end of the run if multiple batches.
AUTO.ST Values <OPT>	
SINGLE, CONT, NUM, TIME	Preset Tare (USE.PT): YES if Preset Tare used for each product recipe. The preset tare is set using the RECIPE key and is activated at the start of the batch.
NUM.CL Values <OPT>	
YES, NO ^(Default)	In-Flight Average (FLT.AV): The number of fill results that are averaged to determine the in-flight setting. (Extreme flight results are not included in the calculation to remove impact of rogue batches when there are more than 5 results averaged) Used with the automatic in-flight correction method.
PROP.TP Values <OPT>	
NONE ^(Default) , PC, PROP, TOTAL, AUTO	Fill Display (F.DISP): show either the END target or the REMAINING weight to target when filling.
PROP.CL Values <OPT>	
YES, NO ^(Default)	
USE.PT Values <OPT>	
YES, NO	
FLT.AV Values <NUM>	

1...100	Jogging target (JOG.TGT):
F.DISP Values <OPT>	TARGET: Jogging to continue until target reached.
END, REMAINING	TOL.LOW: Jogging to continue until low tolerance reached.
JOG.TGT Values <OPT>	Abort Action (ABT.ACT): Action to be taken on the batch being aborted.
TARGET, TOL.LOW	TOTAL: to total material and batch quantities for the aborted batch.
ABT.ACT Values <OPT>	IGNORE: to not include quantities from aborted batches in totals.
TOTAL, IGNORE	Error handling (ERROR): PAUSE to pause batch on system errors, overload or underload with a PAUSE.ERROR prompt displayed.
ERROR Values <OPT>	Tolerance Action (TOL):
IGNORE, PAUSE (Default)	BEEP: beep and continue
TOL Values <OPT>	PAUSE: to pause batch, PAUSE.TOL prompt displayed
NONE (Default), BEEP, PAUSE	Print Out (PRT.OUT): Printout to be used by the batching process.
PRT.OUT Values <OPT>	DSD Use (DSD.USE): When to store data in the DSD if one is fitted.
NONE (Default), PRINT.1, PRINT.2	FILL: store DSD data at the end of every fill stage.
DSD.USE Values <OPT>	BATCH: store DSD data at the end of every batch.
NONE (Default), FILL, BATCH	Batch preference (B.PREF) (K410 and K412 only): Sets the preference for accuracy or speed. If set to speed it will assume the batch started at a gross weight of 0 rather than taking a reading.
B.PREF Values <OPT>	
ACCURACY (Default), SPEED	

14.9.3. MAT (Material)

Path	Description
BATCH L MAT LNAME 1...n	Sets the name of each material. K410 has 1 material K411 has 6 materials K412 has 20 materials
NAME Values <STR>	
8 character string	

14.9.4. STAGES

Path	Description
BATCH L STAGES LNUM LSTAGES 1...10 LINSERT LDELETE	NUM: Number of batch stages. STAGES: Submenus with specific information for each stage. See below. INSERT: A new stage can be inserted anywhere in the existing stages, or added as the last stage (APPEND).
NUM Values <NUM>	
1...10	To insert a new stage within existing stages, scroll through the list of stages and select the stage that the new stage is to be before . The type for this new stage can be set after the prompt TYPE?. DELETE: Scroll through stages and press <OK> to delete the stage.

14.9.5. STAGE.n:FILL

Path	Description
BATCH	Configuration of a FILL stage.
L STAGES	Hardware
L STAGE.n	Slow Fill (S.FILL): Output for slow fill. This output will be used for 1, 2 and 3 speed fills.
L TYPE : FILL	Medium Fill (M.FILL): Output for medium fill. This output will be used for 2 and 3 speed fills.
L S.FILL	Fast Fill (F.FILL): Output for fast fill. This output will be used for 3 speed fills only.
L M.FILL	Input (INPUT): Input used to end fill stage before target weight is reached.
L F.FILL	Wait for input (IN.WAIT): If this is set to ON then the stage will not exit until the input is active.
L INPUT	Interlock (I.LOCK): Input to use as a filling interlock. This input must be on for filling to proceed. If not present the batch is paused automatically. A single input can be used as the interlock for more than one filling stage.
L IN.WAIT	Stage Output (STG.OUT): Output to identify this stage if used.
L I.LOCK	Feeder Control (FEEDER): Select SINGLE when only one feeder is used at any time. Select MULT to allow multiple feeders at the same time. This only applies to 2 or 3 speed fills.
L STG.OUT	Material (MAT) (K411 only): Select material for this FILL stage. (Note that the same material can be filled multiple times in the same batch)
L FEEDER	Action at Start (ST.ACT): Automatic action at the start of this FILL stage.
L MAT	Correction (CORR): Type of correction to be used at the end of this fill stage.
L ST.ACT	Manual (MAN.FLT): Uses in-flight as set by operator only.
L CORR	Jogging (JOG): Jog using in-flight as set by operator.
L DLY.ST	Auto Flight (AUT.FLT): Uses the average in-flight (as set up in the BATCH:GEN) without jogging.
L DLY.CHK	Auto Jog (AUT.JOG): Uses the average in-flight (as set up in the BATCH:GEN) with jogging.
L DLY.END	Delay Start (DLY.ST): Time delay at the start of the stage.
L JOG.ON *	Delay End (DLY.END): Time delay at the end of this stage.
L JOG.OFF *	Hold-Off-Check (DLY.CHK): Stops any weight checks shortly after switching the fill outputs.
L JOG.SET *	Jog Timing (JOG.ON, JOG.OFF): Set how long the Slow Fill output is ON and OFF when jogging.
L MAX.SET *	Number of jogs in a set (JOG.SET): Specifies how many 'jogs' (Slow Fill ON then OFF) are performed
L DIRN	
S.FILL Values <OPT>	
IO1..IO32	
M.FILL Values <OPT>	
NONE, IO1..IO32	
F.FILL Values <OPT>	
NONE, IO1..IO32	
INPUT Values <OPT>	
NONE, IO1..IO32	
IN.WAIT Values <OPT>	
OFF, ON	
I.LOCK Values <OPT>	
NONE, IO1..IO32	
STG.OUT Values <OPT>	
NONE, IO1..IO32	
FEEDER Values <OPT>	
SINGLE, MULT	
MAT Values <OPT>	
1..6	
ST.ACT Values <OPT>	

Path	Description
NONE, TARE, GROSS	<p>before the instrument waits for no motion and checks the weight. If target not reached the process will repeat as necessary.</p> <p>Maximum number of jog sets (MAX.SET): Specifies the maximum number of jog sets should be attempted to reach the target, a setting of 0 is unlimited jog sets.</p> <p>Fill direction (DIRN): Sets if weight should increase or decrease while filling.</p>
CORR Values <OPT>	
JOG, MAN.FLT, AUT.JOG AUT.FLT	
DLY.ST, DLY.END Values <NUM>	
0.0..18,000.0s	
DLY.CHK Values <NUM>	
0.0..60,000.0s	
JOG.ON, JOG.OFF Values <NUM> *	
0.1..60.0s	
JOG.SET Values <NUM> *	
1..20	
MAX.SET Values <NUM> *	
0..20	
DIRN Values <OPT>	
W.IN, W.OUT	
(*) NB only available with JOG and AUT.JOG	

14.9.6. STAGE.n:DUMP

Path	Description
BATCH	Hardware
L STAGES	
L STAGE.n	
L TYPE : DUMP	
L DMP.OUT	Output (DMP.OUT): Output to be used for the dump signal.
L STG.OUT	Stage (STG.OUT): Output to identify this stage
L ON.TOL	Dump Interlock input (I.LOCK): Input to use as a dump interlock. This input must be on for dumping to proceed. If not present, the batch is paused automatically.
L I.LOCK	
L ENABLE	Dump Enable (ENABLE): This input is both edge and level sensitive and must be detected before dump will start.
L EN.LTCH	Enable Latch (EN.LTCH): If set to ON then the dump enable will be detected at any time throughout the batch, if set to OFF then the dump enable will be detected only during the dump stage.
L DMP.TYP	
L CORR	
L DLY.ST	
L DLY.CHK	
L DLY.END	
L JOG.ON	
L JOG.OFF	
L JOG.SET	
L TOL.HI	Tolerance (ON.TOL): Sets if dump stage will run if the batch is in or out of tolerance.
L PLS.TME	Dump Type (DMP.TYP): Can dump for a given length of TIME or to a given WEIGHT.
DMP.OUT Values <OPT>	Correction (CORR): Set JOG to using jogging correction at the end of a dump to weight.
NONE, IO1..IO32	
STG.OUT Values <OPT>	
NONE, IO1..IO32	
ON.TOL Values <OPT>	Delay Start (DLY.ST): Time delay at the start of the stage.
BOTH, IN, OUT	
I.LOCK Values <OPT>	Delay End (DLY.END): Time delay at the end of this stage.
NONE, IO1..IO32	
ENABLE Values <OPT>	Hold-Off-Check (DLY.CHK): stops any weight checks after a decision has been made concerning the outputs. For example, when fast fill changes to slow fill, or when the dump output is first turned on.
NONE, IO1..IO32, F1, F2, F3	
EN.LTCH Values <OPT>	
OFF, ON	
DMP.TYP Values <OPT>	Jog Timing (JOG.ON, JOG.OFF): Set how long the Slow Fill output is ON and OFF when jogging.
WEIGHT, TIME	
CORR Values <OPT>	Number of jogs in a set (JOG.SET): Specifies how many 'jogs' (Slow Fill ON then OFF) are performed before the instrument waits for no motion and checks the weight. If target not reached the process will repeat as necessary.
NONE, JOG	
DLY.ST, DLY.END Values <NUM>	
0.0..18,000.0s	
DLY.CHK Values <NUM>	Dump Target (TOL.HI): Sets maximum weight allowed for dump completion when dumping to weight.
0.0..60,000.0s	
JOG.ON, JOG.OFF <NUM>	
0.1..60.0s	
JOG.SET Values <NUM>*	Pulse Time: Only available when dumping to TIME. Sets number of seconds dump output is ON when dumping to time.
1..20	
TOL.HI Values <NUM>	Note:
0...99,999	(*) only available with JOG

PLS.TME Values <NUM>	(**) only available when WEIGHT type selected
0.10..18,000.00s	(***) only available when TIME type selected

14.9.7. STAGE.n: PULSE

Path	Description
BATCH	<p>A pulse stage is used to switch an output on for a set amount of time. The time is set by the operator using the TIMER key.</p> <p>NAME: 8-character string to name this PULSE stage and to be displayed in the Secondary ID.</p> <p>Hardware</p> <p>Pulse Output (PLS.OUT): The output to be used for the pulse signal.</p> <p>Stage Out (STG.OUT): Output to identify this stage.</p> <p>Input (INPUT): The input used to finish the pulse stage. If NONE is specified, the instrument will wait for a START or OK key. If IGNORE is selected, then the timer will be used instead.</p> <p>Timer (TIMER): Use or ignore timer for pulse stage. If set to ignore then the Input will be used instead.</p> <p>PROMPT: 9-character string to be shown on Secondary Display.</p> <p>Start Action (ST.ACT): Automatic action at the start of this PULSE stage.</p> <p>Delay Start (DLY.ST): Time delay at the start of the stage.</p> <p>Delay End (DLY.END): Time delay at the end of this stage.</p> <p>LINK: This stage can be set to only run if the previous or next stage will run.</p>
L STAGES	
L STAGE.n	
L TYPE : PULSE	
L NAME	
L PLS.OUT	
L STG.OUT	
L INPUT	
L TIMER	
L PROMPT	
L ST.ACT	
L DLY.ST	
L DLY.END	
L LINK	
NAME <STR>	
1..8 characters	
PLS.OUT Values <OPT>	
NONE, IO1..IO32	
STG.OUT Values <OPT>	
NONE, IO1..IO32	
INPUT Values <OPT>	
NONE, IO1..IO32, F1, F2, F3, IGNORE	
TIMER Values <OPT>	
USE, IGNORE	
PROMPT Values <STR>	
1..9 characters	
ST.ACT Values <OPT>	
NONE, TARE, GROSS	
DLY.ST, DLY.END Values <NUM>	
0..18,000s	
LINK Values <OPT>	
NONE, PREV, NEXT	

14.10. ANL.OUT (Analogue Output)

Refer also to 12 Analogue Output page 72.

Path	Description
ANL.OUT	<p>Configures the operation of the analogue transmission.</p> <p>ABS (Absolute Weight): Transmit negative weight values the same as positive weight values.</p> <p>SOURCE: GROSS, NET, GR.or.NT</p> <p>RANGE: Set the weight range. Options are: FULLSCALE: 0 to full scale CUSTOM: Use WGT.LO and WGT.HI</p> <p>WGT.LO (Weight Low): Weight corresponding to the lower analogue limit. (e.g. 0V or 4mA)</p> <p>WGT.HI (Weight High): Weight corresponding to the higher analogue limit. (e.g. 10V or 20mA)</p>
L ABS	
L SOURCE	
L RANGE	
L WGT.LO	
L WGT.HI	
ABS Values <OPT>	
NO (Default), YES	
SOURCE Values <OPT>	
GROSS (Default), NET GR.or.NT	
RANGE Values <OPT>	
FULLSCALE(Default), CUSTOM	
WGT Values <NUM>	
-999999 .. 999999	

14.11. End (Save and exit)

15. Appendix 1: Dimensions

15.1. Dimensions

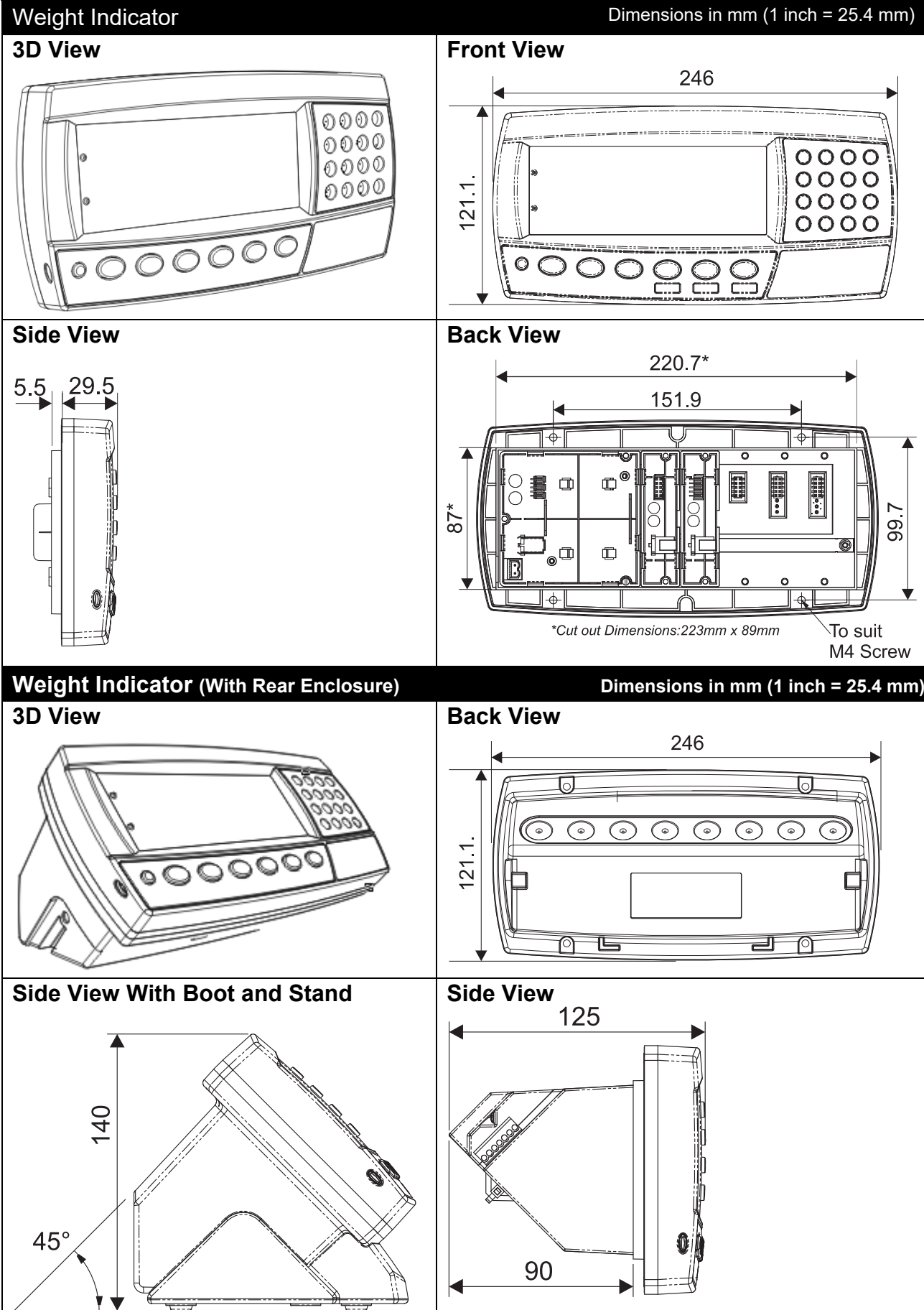

Stainless Steel Weight Indicator

Dimensions in mm (1 inch = 25.4 mm)

3D View

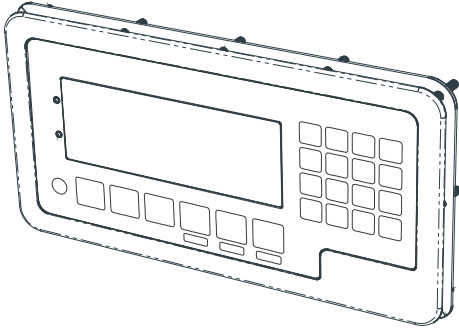

Front View

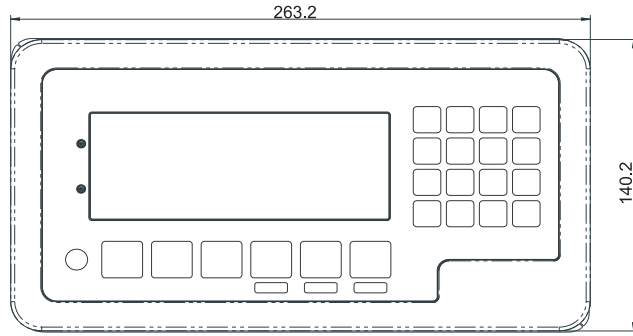

Side View

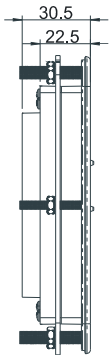

Back View

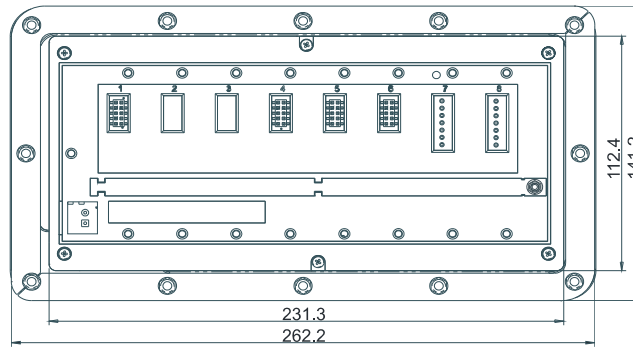

Stainless Steel Weight Indicator

Dimensions in mm (1 inch = 25.4 mm)

(With Rear Enclosure)

3D View

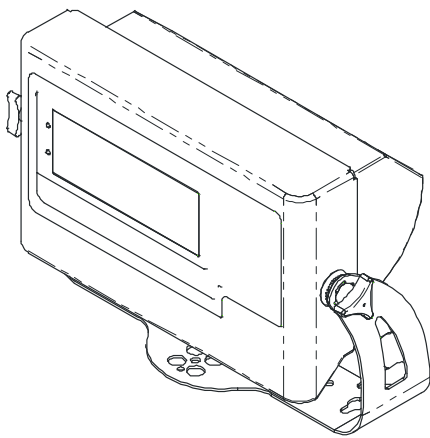

Front View

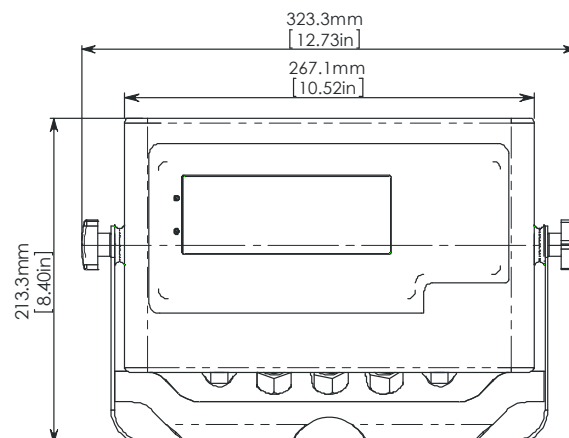

Side View

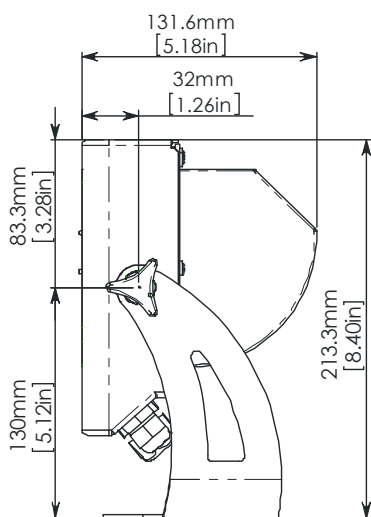

Back View

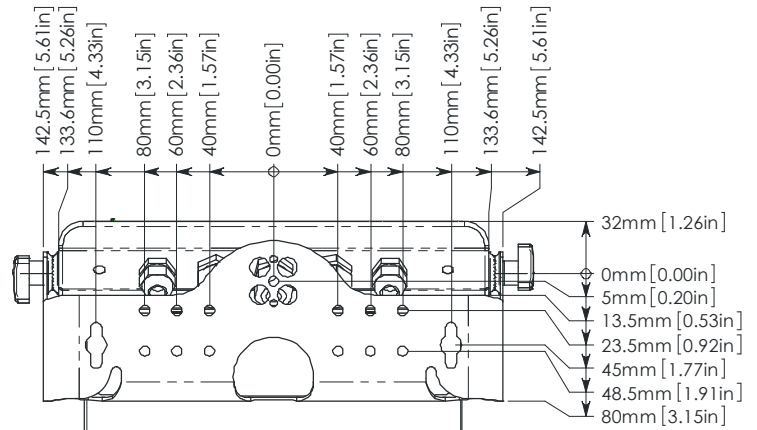

15.2. Legal Sealing Details

There are several methods of legally sealing the instrument. The method chosen will depend on local regulations.

15.2.1. Electronic Seal

The value of the calibration counter should be written on the scale certification/sealing sticker. Refer to 7.1.1 Calibration Counter page 46 for a description of the calibration counter function.

15.2.2. Trade Label

A trade label showing scale and instrument information is usually required. This can be placed on the front of the instrument:

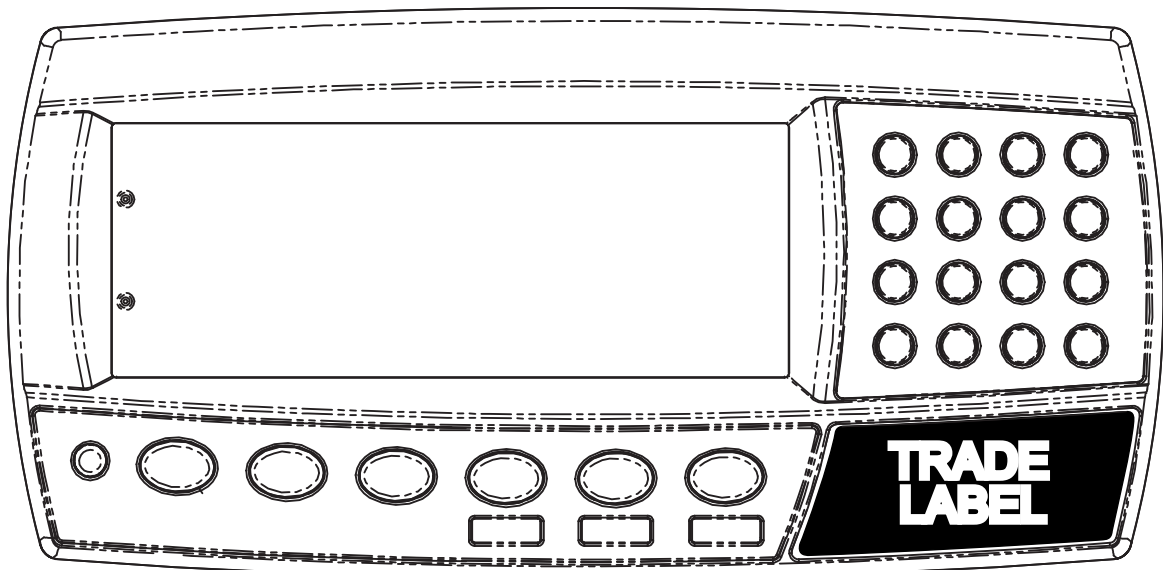

Figure 15: Trade label position.

15.2.3. Lead Seals

There are 2 methods of sealing the instrument with lead and wire seals:

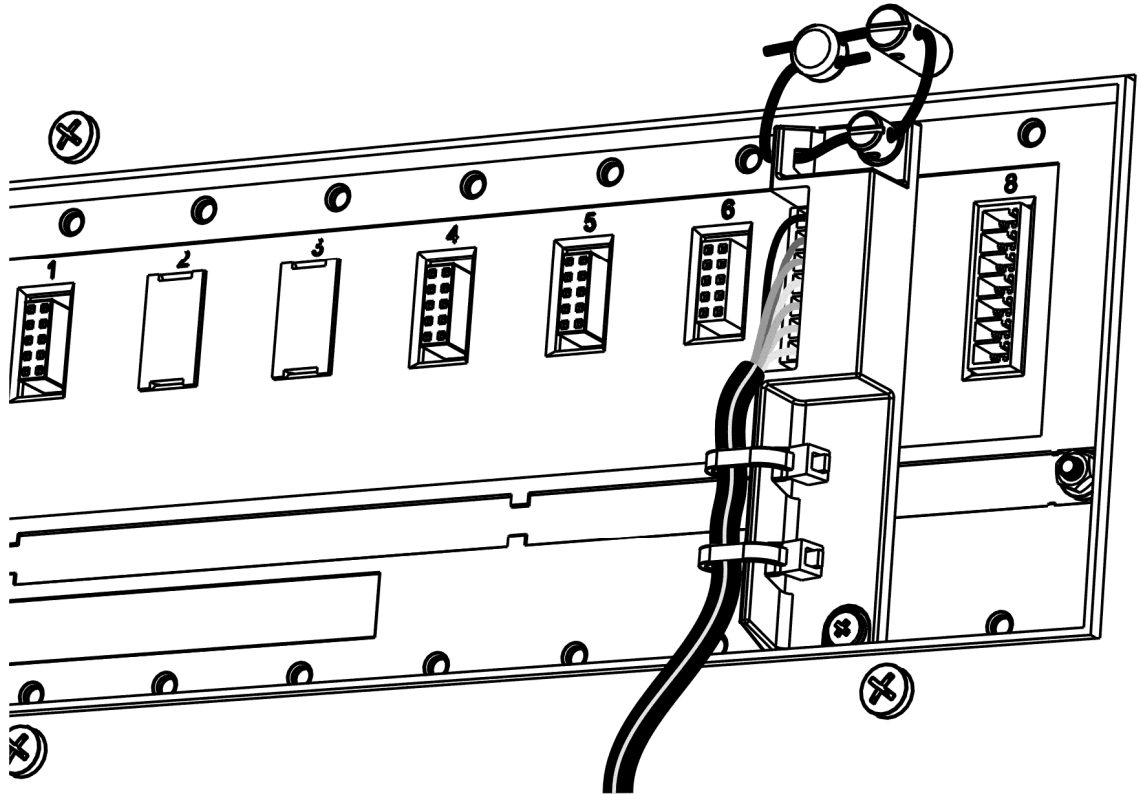

Figure 16: Lead seal on rear of instrument.

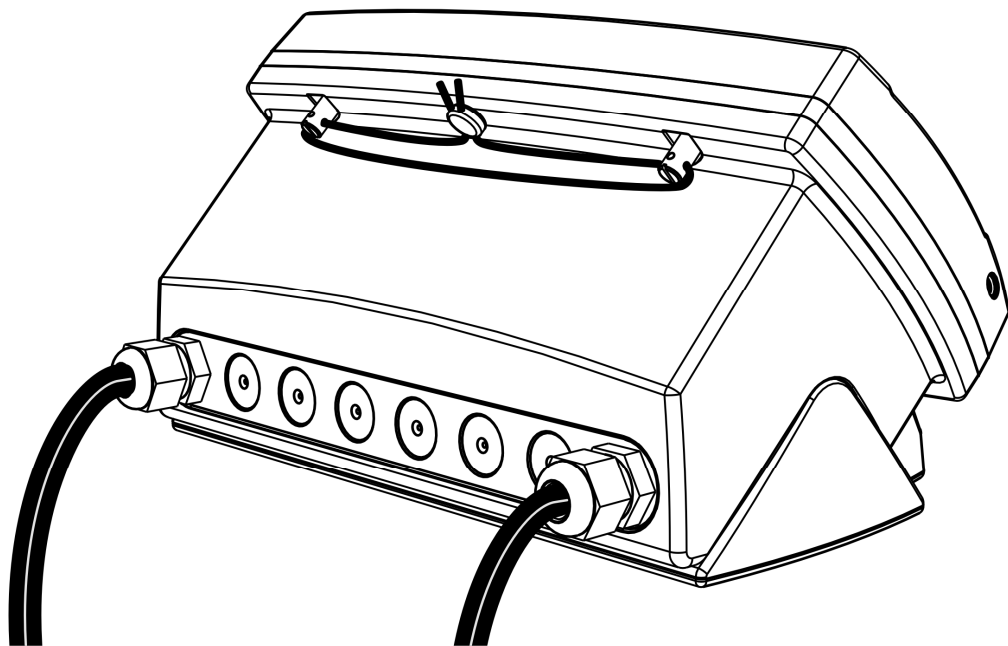

Figure 17: Lead seal on boot.

15.2.4. Destructible Sticker Seals

There are 2 methods of sealing with destructible stickers:

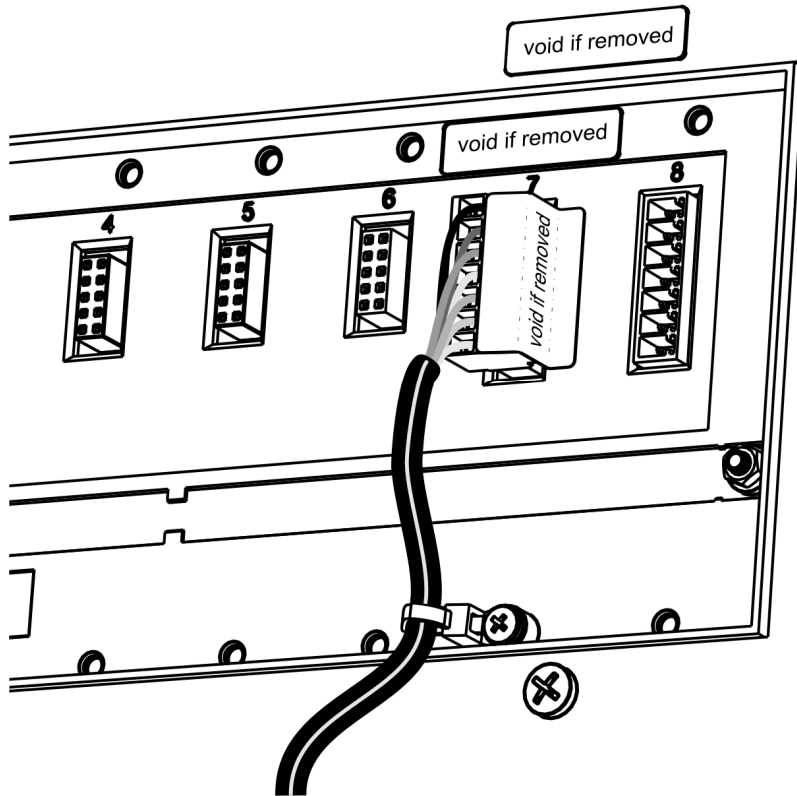

Figure 18: Destructible sticker seal on rear of instrument.

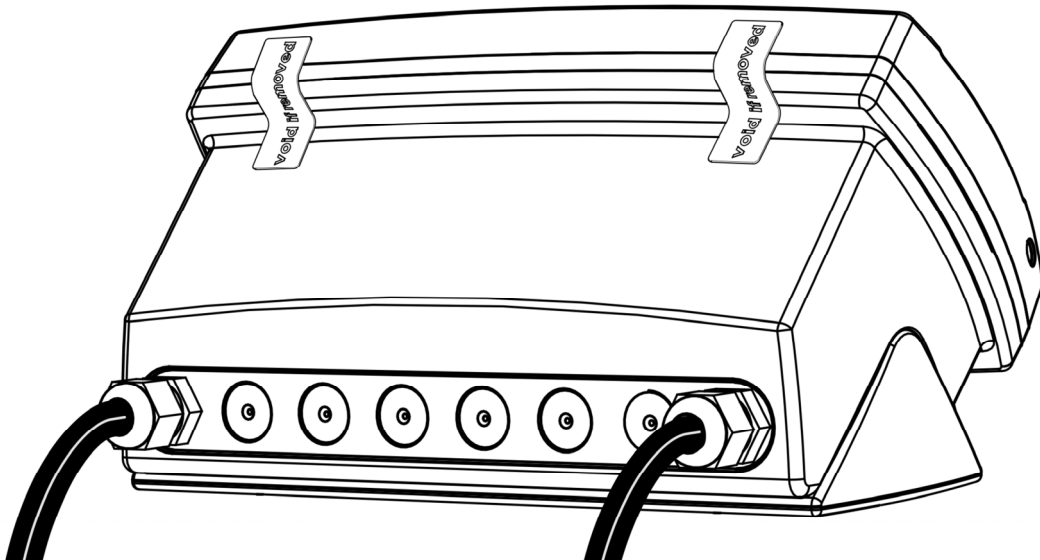

Figure 19: Destructible sticker seal on boot.

Appendix 2: Print and Automatic Transmission Tokens

15.3. ASCII codes

Code	Char	Code	Ch	Code	Ch	Code	Ch	Code	Ch
000 (*)	NULL	026 (1A _H)	SUB**	052 (34 _H)	'4'	078 (4E _H)	'N'	104 (68 _H)	'h'
001 (01 _H)	SOH	027 (1B _H)	ESC	053 (35 _H)	'5'	079(4F _H)	'O'	105 (69 _H)	'i'
002 (02 _H)	STX	028 (1C _H)	FS	054 (36 _H)	'6'	080 (50 _H)	'P'	106 (6A _H)	'j'
003 (03 _H)	ETX	029 (1D _H)	GS	055 (37 _H)	'7'	081 (51 _H)	'Q'	107 (6B _H)	'k'
004 (04 _H)	EOT	030 (1E _H)	RS	056 (38 _H)	'8'	082 (52 _H)	'R'	108 (6C _H)	'l'
005 (05 _H)	ENQ	031 (1F _H)	US	057 (39 _H)	'9'	083 (53 _H)	'S'	109 (6D _H)	'm'
006 (06 _H)	ACK	032 (20 _H)	' '	058 (3A _H)	':'	084 (54 _H)	'T'	110 (6E _H)	'n'
007 (07 _H)	BEL	033 (21 _H)	'!'	059 (3B _H)	','	085 (55 _H)	'U'	111 (6F _H)	'o'
008 (08 _H)	BS	034 (22 _H)	'"'	060 (3C _H)	'<'	086 (56 _H)	'V'	112 (70 _H)	'p'
009 (09 _H)	HT	035 (23 _H)	'#'	061 (3D _H)	'='	087 (57 _H)	'W'	113 (71 _H)	'q'
010 (0A _H)	LF	036 (24 _H)	'\$'	062 (3E _H)	'>'	088 (58 _H)	'X'	114 (72 _H)	'r'
011 (0B _H)	VT	037 (25 _H)	'%'	063 (3F _H)	'?'	089 (59 _H)	'Y'	115 (73 _H)	's'
012 (0C _H)	FF	038 (26 _H)	'&'	064 (40 _H)	'@'	090 (5A _H)	'Z'	116 (74 _H)	't'
013 (0D _H)	CR	039 (27 _H)	'''	065 (41 _H)	'A'	091 (5B _H)	'['	117 (75 _H)	'u'
014 (0E _H)	SO	040 (28 _H)	'('	066 (42 _H)	'B'	092 (5C _H)	'\'	118 (76 _H)	'v'
015 (0F _H)	SI	041 (29 _H)	')'	067 (43 _H)	'C'	093 (5D _H)	']'	119 (77 _H)	'w'
016 (10 _H)	DLE	042 (2A _H)	'*'	068 (44 _H)	'D'	094 (5E _H)	'^'	120 (78 _H)	'x'
017 (11 _H)	DC1	043 (2B _H)	'+'	069 (45 _H)	'E'	095 (5F _H)	'_'	121 (79 _H)	'y'
018 (12 _H)	DC2	044 (2C _H)	','	070 (46 _H)	'F'	096 (60 _H)	''	122 (7A _H)	'z'
019 (13 _H)	DC3	045 (2D _H)	'-'	071 (47 _H)	'G'	097 (61 _H)	'a'	123 (7B _H)	'{'
020 (14 _H)	DC4	046 (2E _H)	'.'	072 (48 _H)	'H'	098 (62 _H)	'b'	124 (7C _H)	' '
021 (15 _H)	NAK	047 (2F _H)	'/'	073 (49 _H)	'I'	099 (63 _H)	'c'	125 (7D _H)	'}'
022 (16 _H)	SYN	048 (30 _H)	'0'	074 (4A _H)	'J'	100 (64 _H)	'd'	126 (7E _H)	'~'
023 (17 _H)	ETB	049 (31 _H)	'1'	075 (4B _H)	'K'	101 (65 _H)	'e'	127 (7F _H)	DEL
024 (18 _H)	CAN	050 (32 _H)	'2'	076 (4C _H)	'L'	102 (66 _H)	'f'		
025 (19 _H)	EM	051 (33 _H)	'3'	077 (4D _H)	'M'	103 (67 _H)	'g'		

Table 7: ASCII Table

(*) Use ASCII 128 to implement a literal NULL character in a custom string. ASCII 0 is used to define the end of the string.

(**): Sub (1A_H) is used as a special character. Insert 2 consecutive SUB characters into a token string to print 1 SUB character.

15.4. Tokens

Tokens are special ASCII characters outside the normal printing range. These characters are used to specify where instrument data fields like 'Current Weight' are to be inserted into custom format strings.

15.4.1. Non-paged generic tokens

Code	Token
026 (1A _H)	The character following this character in the token string will be printed regardless of its value. Enter this character twice to print this character. E.g. \1A\80 will print the ascii code 80 _H and not 00 _H (see next code).
128 (80 _H)	ASCII NULL (send an ASCII 00 _H character)
191 (BF _H)	Date
192 (C0 _H)	Time
193 (C1 _H)	Newline
194 (C2 _H)	Left spaces
195 (C3 _H)	Top blank lines
196 (C4 _H)	Bottom blank lines
197 (C5 _H)	Unique consecutive print ID
198 (C6 _H)	Header
199 (C7 _H)	Footer
200 (C8 _H)	Page end string
201 (C9 _H)	User String Data 1
202 (CA _H)	User String Data 2
203 (CB _H)	User String Data 3
206 (CE _H)	User String Name 1
207 (CF _H)	User String Name 2
208 (D0 _H)	User String Name 3
213 (D5 _H)	Settable consecutive print ID
214 (D6 _H)	Reset to 1 the settable consecutive print ID

Table 8: Print tokens: generic

15.4.2. Page tokens

As there is too much data to represent as individual tokens so the tokens are divided up into pages. A page token is used to define the page for all subsequent tokens.

Code	Token
190 (BE _H)	Page 0: Current Weight
189 (BD _H)	Page 1: Current Stage
188 (BC _H)	Page 2: Current Batch
186 (BA _H)	Page 4: Current Product
184 (B8 _H)	Page 6: Grand Total
183 (B7 _H)	Page 7: Register Data
182 (B6 _H)	Page 8: Material Totals

Table 9: Print tokens: pages

15.4.3. Page 0, 7 tokens: Weight Information

These pages hold weight information. The same codes are used for each page.

Code	Token	
215 (D7 _H)	Displayed reading (gross or net)	
216 (D8 _H)	Gross reading	
217 (D9 _H)	Net reading	
218 (DA _H)	Piece reading	
219 (DB _H)	Alternative displayed reading (gross or net)	
220 (DC _H)	Alternative gross reading	
221 (DD _H)	Alternative net reading	
222 (DE _H)	mV/V value	
223 (DF _H)	Absolute gross peak reading	
224 (E0 _H)	Preset tare value	
225 (E1 _H)	Tare value (tare or preset tare)	
226 (E2 _H)	Tare label (T or PT)	
227 (E3 _H)	Unit ID	page 0 only
	Register Header	Page 7 only
228 (E4 _H)	Ticket end	page 0 only
	Register Footer	Page 7 only
229 (E5 _H)	Status 0: Error, Overload, Underload, Motion, Net, Gross (Uses last weight sent)	page 0 only
230 (E6 _H)	Status 1: Error, Overload, Underload, Net, Gross (Uses last weight sent)	page 0 only
231 (E7 _H)	Status 2: Motion , ‘ ‘	page 0 only
232 (E8 _H)	Status 3: Centre of Zero , ‘ ‘	page 0 only
233 (E9 _H)	Status 4: -, Range 1 , Range 2 (Uses last weight sent)	page 0 only
234 (EA _H)	Status 5: C , Motion , ‘ ‘	page 0 only
235 (EB _H)	Status 6: _N_ Net, _G_ Gross (Uses last weight sent)	page 0 only
236 (EC _H)	Status 7: Error, Overload, Underload, Motion, Net, Gross (Uses automatic transmission reading)	page 0 only
237 (ED _H)	Automatic transmit reading	page 0 only
238 (EE _H)	Automatic transmit start characters	page 0 only
239 (EF _H)	Automatic transmit end characters	page 0 only
240 (F0 _H)	Weight units	page 0 only
241 (F1 _H)	Displayed string (primary display)	page 0 only
242 (F2 _H)	Displayed unit (primary display)	page 0 only
243 (F3 _H)	Auto Transmit FMT.REG header	page 0 only
244 (F4 _H)	Auto Transmit FMT.REG weight	page 0 only
245 (F5 _H)	Auto Transmit FMT.REG status	page 0 only
246 (F6 _H)	Auto Transmit FMT.REG footer	page 0 only
248 (F8 _H)	Status 8: Overload, Underload, In range	page 0 only
249 (F9 _H)	Status 9: Motion, Stable	page 0 only
250 (FA _H)	Status 10: OL over/underload, US unstable, ST stable	page 0 only
251 (FB _H)	Status 11: Gross, Net	page 0 only

Table 10: Print tokens: weight information

15.4.4. Page 1, 2 tokens: Current Stage and Batch Information

Code	Token
215	(D7 _H) Stage/Product name. E.g. Material name for fills and configured name for wait and pulse stages.
216	(D8 _H) Configured prompt used with pulse stages
219	(DB _H) Gross weight at stage/batch start
220	(DC _H) Gross weight at stage/batch end
221	(DD _H) Displayed reading at stage/batch end
222	(DE _H) total weight added during stage (220 - 219)
223	(DF _H) Total weight error. Fill stages. Final weight - target weight
224	(E0 _H) Actual target weight. Fill stages.
225	(E1 _H) Logical target weight
226	(E2 _H) Weight remaining to be filled
227	(E3 _H) Stage/Batch Time: hh.mm.ss
228	(E4 _H) Stage/Batch Time: milliseconds
229	(E5 _H) Stage/Batch Time: Seconds
230	(E6 _H) Stage/Batch Time: Minutes
231	(E7 _H) Stage/Batch Time: Hours
232	(E8 _H) Status 16: Running , Paused , Idle
233	(E9 _H) Stage Number
234	(EA _H) Status 17: Slow , Medium , Fast , Time , Input , Jog
235	(EB _H) Reason for batch abort.

15.4.5. Page 4, 6 tokens: Product and Grand Total Information

These pages hold product information where:

Code	Token
215 (D7 _H)	Product name
216 (D8 _H)	Barcode
217 (D9 _H)	Total weight
218 (DA _H)	Batch error as a percentage of total weight (total error / total weight)
219 (DB _H)	Average time batching (Total time / num batches)
220 (DC _H)	Number of adds
221 (DD _H)	Total docket weight
224 (E0 _H)	Number of docket adds
225 (E1 _H)	Preset tare
226 (E2 _H)	Total batching error
227 (E3 _H)	Average batching error (total error / num batches)
228 (E4 _H)	Counting piece weight
229 (E5 _H)	Alternative weight conversion
233 (E9 _H)	Last weight added
234 (EA _H)	Number of fills required to make the total (as opposed to number of batches). Grand Total only.
235 (EB _H)	Last pieces added
236 (EC _H)	Clear docket totals
237 (ED _H)	Reset last product add

Table 11: Print tokens: Product and Grand Total Information**15.4.6. Page 8 Tokens: Material Totals**

Code	Token
215 (D7 _H)	Material name
217 (D9 _H)	Material Used
226 (E2 _H)	Additional material used due to errors
227 (E3 _H)	Average additional material (total material error / num material fills)
218 (DA _H)	Additional material used as a percentage of total usage (total material error / total material used)
220 (DC _H)	Number of fills for this material

15.4.7. Format tokens

Format tokens define the behaviour of all subsequent tokens in a string.

Code	Format Tokens
149 (95 _H)	5-character weight string, decrementing to 3 with wrapping (5,4,3,5...)
150 (96 _H)	6-character weight string
151 (97 _H)	7-character weight string
152 (98 _H)	8-character weight string
153 (99 _H)	9-character weight string
154 (9A _H)	10-character weight string
155 (9B _H)	No sign characters
156 (9C _H)	Sign is ' ' for positive and '-' for negative
157 (9D _H)	Sign is '0' for positive and '-' for negative
158 (9E _H)	Sign is '+' for positive and '-' for negative
159 (9F _H)	No decimal point
160 (A0 _H)	Decimal point is '.'
161 (A1 _H)	Decimal point is ','
162 (A2 _H)	Weight sent without leading characters
163 (A3 _H)	Weight sent with ' ' for leading characters
164 (A4 _H)	Weight sent with '0' for leading characters
165 (A5 _H)	Show weight on error
166 (A6 _H)	Show dashes instead of weight on error
167 (A7 _H)	Show spaces instead of weight on error
168 (A8 _H)	Use uppercase status characters
169 (A9 _H)	Use lowercase status characters
170 (AA _H)	Don't show units
171 (AB _H)	Show decimal point even if it is at the end of a number
172 (AC _H)	Turn page and line tracking off
173 (AD _H)	Toggle space between weight and units
174 (AE _H)	Increment the length or print IDs with wrapping from 6 to 9
175 (AF _H)	Don't show weight
177 (B1 _H)	Put the sign character adjacent to weight
178 (B2 _H)	Add traffic lights to sign characters

Table 12: Print tokens: formatting

Printouts have default format tokens of:

- Weight
 - 8-character weight string
 - Decimal point symbol is ‘.’
 - Leading characters are spaces
 - Weight is sent on error
 - Positive sign is space, negative sign is ‘-’
 - Weights are displayed with units
 - Status characters are uppercase
- Time
 - Date separator is ‘/’
 - Time separator is ‘:’
 - Date format is the format configured in the setup menu
 - Time is 24-hour
- Line and page tracking are enabled

16. Appendix 3: Communications Registers

The viewer software shows the register address for each setting in the menu structure. Register addresses are not guaranteed to stay the same between software types and versions.

Name	Address	Type	Description																														
Software Model	0003 _H	String	Returns software loaded (e.g. K402)																														
Software Version	0004 _H	String	Returns software version (e.g. V1.0)																														
Serial Number	0005 _H	Number	Returns instrument serial number																														
Key buffer entry	0008 _H	Number	<p>Adds a key to the key buffer. The short press key codes are shown below. For long presses, set the most significant bit to 1.</p> <p>Key codes are:</p> <table> <tr> <td>00_H: 0</td> <td>0E_H: F1</td> <td>15_H: DOWN</td> </tr> <tr> <td>:</td> <td>0F_H: F2</td> <td>16_H: OK</td> </tr> <tr> <td>09_H: 9</td> <td>10_H: F3</td> <td>17_H: SETUP</td> </tr> <tr> <td>0A_H:</td> <td>11_H: +/-</td> <td>20_H: IO1</td> </tr> <tr> <td>Power</td> <td>12_H: DP</td> <td>:</td> </tr> <tr> <td>0B_H:</td> <td>13_H: CANCEL</td> <td>3F_H: IO32</td> </tr> <tr> <td>Zero</td> <td>14_H: UP</td> <td></td> </tr> <tr> <td>0C_H:</td> <td></td> <td></td> </tr> <tr> <td>Tare</td> <td></td> <td></td> </tr> <tr> <td>0D_H: G/N</td> <td></td> <td></td> </tr> </table>	00 _H : 0	0E _H : F1	15 _H : DOWN	:	0F _H : F2	16 _H : OK	09 _H : 9	10 _H : F3	17 _H : SETUP	0A _H :	11 _H : +/-	20 _H : IO1	Power	12 _H : DP	:	0B _H :	13 _H : CANCEL	3F _H : IO32	Zero	14 _H : UP		0C _H :			Tare			0D _H : G/N		
00 _H : 0	0E _H : F1	15 _H : DOWN																															
:	0F _H : F2	16 _H : OK																															
09 _H : 9	10 _H : F3	17 _H : SETUP																															
0A _H :	11 _H : +/-	20 _H : IO1																															
Power	12 _H : DP	:																															
0B _H :	13 _H : CANCEL	3F _H : IO32																															
Zero	14 _H : UP																																
0C _H :																																	
Tare																																	
0D _H : G/N																																	
Secondary Display Left	000E _H	String	Write to this register to display data on left side of Secondary Display. Note: The display must be in Top mode.																														
Secondary Display Right	000F _H	String	Write to this register to display data on left side of Secondary Display. Note: The display must be in Top mode.																														
Save Settings	0010 _H	Execute	Execute function with no parameters saves any FULL or SAFE setup changes. Operator changes are saved automatically																														
Enter Full Passcode	0019 _H	Number	<p>Write a Passcode to this register to unlock settings protected by a FULL Passcode</p> <p>If a full passcode has been set, this must be done before any registers (which require a full passcode) are accessed.</p> <p>Example:</p> <p>Sent (passcode 1):20120019; Response: 81120019:0000</p>																														
Enter Safe Passcode	001A _H	Number	Write a Passcode to this register to unlock settings protected by a SAFE Passcode																														
ADC Sample Number	0020 _H	Number	Read current sample number since last power on. (32 bit)																														
System Status *	0021 _H	Number	<p>This register can be read to obtain the status of the instrument.</p> <p>32 status bits sent as 8 hex chars, where:</p> <p>00020000_H: Overload 00010000_H: Underload</p>																														

Name	Address	Type	Description	
			00008000 _H : Error (see System Error) 00004000 _H : SETUP menus active 00002000 _H : Calibration in progress 00001000 _H : Motion 00000800 _H : Centre of Zero 00000400 _H : Zero 00000200 _H : Net For calibration, bit 13 (00002000 _H) is high when a calibration is taking place. Example: Send (status):20110021; Response (not calibrating): 81110021:00008400 Or Response (calibrating): 81110021:0000A400	
System Error	0022 _H	Number	Diagnostic Errors	
Absolute mV/V	0023 _H	Number	Absolute mV/V reading where 10000 = 1.0mV/V	
Unused	0024 _H	Number		
Gross/Net Weight	0025 _H	Number	These registers return weight data. Read Final: 8-character Hexadecimal number. Example: 00000064 for 100 kg Read Literal: Formatted string including decimal point units and Gross/Net indication. Example: " 10.0 kg N"	
Gross Weight	0026 _H	Number		
Net Weight	0027 _H	Number		
Tare Weight	0028 _H	Number		
Peak Hold	0029 _H	Number		
Manual Hold	002A _H	Number		
Grand Total	002B _H	Number		
Raw ADC counts	002D _H	Number		2,560,000 = 1.0mV/V
System Fullscale	002F _H	Number		Fullscale weight of the instrument.
Traceable weight available flag	0030 _H	Number	0: No traceable weights since start up 1: Traceable weight data is valid	
Traceable ID	0031 _H	Number	The unique ID for the traceable weight.	
Traceable weight	0032 _H	Number	Traceable weight in primary units	
Traceable tare weight	0035 _H	Number	Tare weight valid during traceable weight.	
Traceable PT flag	0036 _H	Number	0: no preset tare 1: preset tare	
Traceable date: year	0037 _H	Number	Date and time that the traceable was acquired.	
Traceable date: month	0038 _H	Number		
Traceable date: day	0039 _H	Number		
Traceable date: hour	003A _H	Number		
Traceable date: minute	003B _H	Number		
Traceable date: second	003C _H	Number		
Stream Data	0040 _H	Block	Returns a block of data which is selected in	

Name	Address	Type	Description
			Stream Register 1 .. 5. Use a read command to read a single set of data. Use an execute command (with a parameter of 1) to switch on automatic transmission
Stream Mode	0041 _H	Option	0: Manual - read 'Stream Data' register 1: Auto sync - Data is sent whenever new readings are available. 2: Auto 10Hz – Data is sent at 10Hz 3: Auto 3Hz – Data is sent at 3Hz 4: Auto 1Hz – Data is sent at 1Hz
Stream Register 1..5	0042 _H .. 0046 _H	Option	1..16 selects registers from ADC Sample (0020 _H) to System Fullscale (002F _H). 17 is IO Status (0051 _H)
Print Token with Header	004B _H	String	Replies with print tokens including a valid rinCmd header.
Print Token String	004C _H	String	Sends a string to the configured printer port. The string can contain print tokens.
Reply Token String	004D _H	String	Same as 004C _H except that the completed string is returned to the sender.
Reply registers	004E _H	String	Get the value of multiple number registers in a single read. The register IDs are listed in hexadecimal. All numbers are returned as 32-bit. Example: To get the net and tare weights, send "2012004E:00270028;".
Reply Stream ID	004F _H		Same as register 004E _H except that stream IDs are used. Example: To get the first 3 items of stream data, send "2012004F:010203;".
IO Status	0051 _H	Number	32 bits of IO status sent as 8 hex chars
Piece Weight	0053 _H	Number	The current weight in pieces
Pulse count 1	0055 _H	Number	Number of pulses in IO1 since last reset
Pulse count 2	0056 _H	Number	Number of pulses in IO2 since last reset
Pulse count 3	0057 _H	Number	Number of pulses in IO9 since last reset
Pulse count 4	0058 _H	Number	Number of pulses in IO10 since last reset
Pulse count 5	0059 _H	Number	Number of pulses in IO17 since last reset
Pulse count 6	005A _H	Number	Number of pulses in IO18 since last reset
Pulse count 7	005B _H	Number	Number of pulses in IO25 since last reset
Pulse count 8	005C _H	Number	Number of pulses in IO26 since last reset
Settable Consecutive Print ID	007A _H	Number	The settable consecutive print ID.
User ID strings 1 .. 3	0090 _H ..	String	These strings are also accessed via the ID

Name	Address	Type	Description
	0092 _H		function on the keypad.
The following registers relate to calibration (marked with *).			
Calibration weight *	0100 _H	Number	<p>This register is used to set the calibration weight for span and linearity calibrations. Weights are sent in decimal or hexadecimal (depending on command used). They must be in displayed weight without decimal point or units.</p> <p>Example:</p> <ul style="list-style-type: none"> • 10.00kg → 1000 → 3E8H • 1000kg → 1000 → 3E8H • 0.1000t → 1000 → 3E8H <p>Example:</p> <p>Sent (10.00kg): 20120100:3E8 Response(ok): 81120100:0000</p>
Zero calibration *	0102 _H	Execute	<p>This register is used to perform a zero calibration in the same way as the zero calibration via the menus. The display will change to indicate that a zero calibration is taking place.</p> <p>Example:</p> <p>Sent (calibrate): 20100102 Response (ok): 81110102:00000000 Send (status?): 20110021 Response (calibrating): 81110021:0000A400 Send (status?): 20110021 Response (calibrating): 81110021:0000A400 Send (status?): 20110021 Response (not calibrating): 81110021:00008400</p>
Span calibration *	0103 _H	Execute	<p>This register is used to perform a span calibration in the same way as the span calibration via the menus. The display will change to indicate that a span calibration is taking place. The calibration weight must be entered before a span is executed using register 0100H.</p> <p>Example:</p> <p>Sent (1000kg cal weight): 20120100:3E8 Response(ok): 81120100:0000 Sent (calibrate): 20100103 Response (ok): 81110103:00000000 Send (status?): 20110021 Response (calibrating): 81110021:0000A400 Send (status?): 20110021 Response (calibrating): 81110021:0000A400 Send (status?): 20110021 Response (not calibrating): 81110021:00008400</p>
Linearity calibration *	0104 _H	Execute	This register is used to perform linearity

Name	Address	Type	Description
			<p>compensation. Up to 10 linearity points can be used [numbered 0 .. 9]. The calibration weight must be entered, using register 0100H, before doing a linearity calibration. The display will change to show that a linearisation is taking place. The linearisation point number is sent as a parameter [numbered 0 .. 9].</p> <p>Example:</p> <p>Sent (5000kg cal weight): 20120100:1388 Response(ok): 81120100:0000 Sent (calibrate 1st point): 20100104:0 Response (ok): 81100103:00000000 Send (status?): 20110021 Response (calibrating): 81110021:0000A400 Send (status?): 20110021 Response (calibrating): 81110021:0000A400 Send (status?): 20110021 Response (not calibrating): 81110021:00008400</p>
Clear Linearity *	0105 _H	Execute	<p>This register clears a previously entered linearisation calibration. There are 10 linearisation points [numbered 0 .. 9] which can be cleared separately. The linearisation point to clear is sent as a parameter.</p> <p>Example:</p> <p>Sent (Clear 1st point): 20100105:0 Response (ok): 81100105:00000000</p>
Direct zero calibration*	0106 _H	Execute	<p>This register is used to perform a direct zero calibration in the same way as the direct zero calibration via the menus. A direct zero calibration is very fast and the display may not change in the same way as a zero calibration.</p> <p>The mV/V value is sent as a parameter. It is sent as mV/V x 10000. Example:</p> <ul style="list-style-type: none"> • 0.5mV/V → 5000 → 1388H • 1.0mV/V → 10000 → 2710H • 2.5mV/V → 25000 → 61A8H <p>Example:</p> <p>Sent (0.5mV/V): 20100106:1388 Response(ok): 81100106:00000000</p>
Direct span calibration*	0107 _H	Execute	<p>This register is used to perform a direct span calibration in the same way as the direct span calibration via the menus. A direct span calibration is very fast, and the display may not change in the same way as a span calibration.</p> <p>The mV/V value OF FULLSCALE is sent as a parameter. It is sent as mV/V x 10000. E.g:</p> <ul style="list-style-type: none"> • 0.5mV/V → 5000 → 1388H

Name	Address	Type	Description
			<ul style="list-style-type: none"> • 1.0mV/V → 10000 → 2710H • 2.5mV/V → 25000 → 61A8H Example use: Sent (1.0mV/V): 20100107:2710 Response(ok): 81100106:00000000
Current Time/Date	0150 _H	String	Read this register to get instrument date/time settings (e.g. 10/12/2005 18:30:10). (Can be SAFE Passcode protected)
Date Format	0151 _H	Option	Write 0 for MMDDYYYY or 1 for DDMMYYYY
Day	0152 _H	Number	Read/Write current day (1..31)
Month	0153 _H	Number	Read/Write current month (1..12)
Year	0154 _H	Number	Read/Write current year (2000..2099)
Hour	0155 _H	Number	Read/Write current hour (0..23)
Minute	0156 _H	Number	Read/Write current minute (0..59)
Second	0157 _H	Number	Read/Write current second (0..59)
Grand Total Weight	0220 _H	Number	Grand total information
Grand Total Num	0223 _H		
Grand Total Batch Time	0224 _H		
GT Average Batch Time	0225 _H		
Grand Total Batch Error	0226 _H		
GT Batch Error as %	0227 _H		
GT Average Batch Error	0228 _H		
Lua Status	0305 _H	Number	Menu active bit to be true when in any editor or prompt where the key handling is changed.
The following registers relate to the DSD.			
Auto clear DSD	8290 _H	Option	Auto write over oldest records when full (0..1)
Read DSD Record	8291 _H	Execute	Reads requested DSD record
Read Next DSD Record	8292 _H	Execute	Reads next DSD record
Read Prev. DSD Record	8293 _H	Execute	Reads Previous DSD record
Read Oldest Record	8294 _H	Execute	Reads Oldest DSD record
Read Newest Record	8295 _H	Execute	Reads Newest DSD record
Clear DSD	8296 _H	Execute	Clears all records on DSD
The Active Product is the product shown on the instrument display. It is the product which is currently active in the instrument.			
Change Active Product using Product number	B000 _H	Number	Write number to change the active product. Read to find out active product number.
Clear all Totals	B002 _H	Execute	Execute to clear All Totals
Clear Docket Totals	B004 _H	Execute	Execute to clear printing Docket Totals only
Change Active Product using Product Name	B006 _H	String	Write name to change the active product. Read to find out name of active product.
All changes to product information are made to the selected product. This product is selected via the communications and is used for network commands only. It may be different to the active product in the instrument.			

Name	Address	Type	Description
Select product by name	B00F _H	String	Write name to select product, read to find out selected product name.
Select product by number	B010 _H	Number	Write number to select product, read to find out selected product number.
The following registers all work with the Selected Product.			
Delete	B011 _H	Execute	Execute with no parameters to delete the selected product. This can be done only if the product total is zero.
Re-name	B012 _H	String	Write to change name of selected product.
Name	B013 _H	String	Read selected product name.
Total Weight	B102 _H	Number	Product total information
Total Num	B105 _H		
Total Batch Time	B106 _H		
Average Batch Time	B107 _H		
Total Batch Error	B108 _H		
Percentage Batch Error	B109 _H		
Average Batch Error	B10A _H		
Total Docket Weight	B180 _H	Number	Product docket total information
Total Docket Num	B183 _H		

17. Appendix 4: Setup Menu Quick Reference

Note: ⊗ Read-only Safe Setup. Changing this setting **will increment** the Calibration Counter.

1 Read-only Safe Setup. Changing this setting **will not increment** the Calibration Counter.

L1	L2	L3	L4	Item	
GEN.OPT	DATE.F			Date Format	
	P.CODE	SAFE.PC		Safe setup passcode	
		FULL.PC		Full setup passcode	
		OP.PC		Operator passcode	
	KEY.LOC	P		Power key lock	
		ZERO, TARE, RECIPE		Fixed Function Keys	
		F1,F2,F3		Programmable Function Keys	
		CLOCK, DISP etc		Operator Functions	
	DISP	B.LIGHT		Backlight operation	
		FREQ		Display update frequency	
		AUX.DSP		Auxiliary display function	
		VIEW		Default View	
	ID.NAME	NAME.1 .. NAME.5		Names for the five User ID strings	
	USR.NU M	NAME.1 .. NAME.5		Names for the five User strings	
POWER	AUTO.OFF		Auto-off		
	START		Pause on Start-Up		
STR.EDT			String editor mode		
USR.DEF			User defaults		
H.WARE	LC.HW	MVV, OL.CNT, OL.CLR		mV/V test	
	SER1.HW SER2.HW	BAUD, PARITY, DATA, etc.		Settings for serial port 1 (SER1.HW) and the optional serial port 2 (SER2.HW).	
	ETH.HW	DHCP, IP, G.WAY		IP configuration settings for the M4221 module	
	ETH.HW	ETH.DEF		Reset the M4221 Ethernet module to defaults	
	IO.HW	FRC.OUT		Force outputs test	
	IO.HW	TST.IN		Check inputs test	
	ANL.HW	DB.1.8 - DB.25.32	DBNC.1 – DBNC.32		Debounce settings for inputs
		TYPE		Voltage or current selection	
	ANL.HW	CLIP		Output clip enable	
		FRC.OUT		Force analogue output test	
		ANL.CAL	ADJ.LO		Adjust lo output (4mA or 0V)
			ADJ.HI		Adjust hi output (20mA or 10V)
	DSD.HW BUILD	AUTO.C		Automatically clear oldest records when DSD full	
DSD.STR		Custom string to store with DSD records			
SCALE	BUILD OPTION	TYPE		Range type	
		CABLE		6-WIRE or 4-WIRE	
		DP		Decimal Point position	
		CAP1		Capacity of Scale / Range 1 / Interval 1	
		E1		Resolution of Scale / Range 1 / Interval 1	
		CAP2		Capacity of Scale / Range 2 / Interval 2	
		E2		Resolution of Scale / Range 2 / Interval 2	
		UNITS		Scale Units	
	HI.RES		x10 Expanded mode		
	OPTION CAL	USE		Trade Use	
		FILTER		Averaging	
		MOTION		Motion Detection	
		Z.RANGE		Range of Zero	
		Z.TRACK		Zero Tracking	

L1	L2	L3	L4	Item	
		Z.INIT		Zero on Startup	
		Z.BAND		Band of Zero	
		EXT.EX		External excitation	
		TOT.OPT		Totalising option	
	CAL QA	ZERO		Calibrate Zero	
		SPAN		Calibrate Span	
		ED.LIN		Set Linearisation	
		CLR.LIN		Clear Linearisation	
		DIR.ZER		Direct mV/V Zero Calibration	
		DIR.SPN		Direct mV/V Span Calibration	
		DEF.CAL		Default Calibration	
QA	QA.OPT		QA Enable		
	QA.YEAR, QA.MONTH QA.DAY		QA Expiry Date		
FUNC	NUM			Number of special functions	
	SF1 – SF8 TYPE	TYPE		Type	
		KEY		Key assignment (Not for Thumbwheel)	
		PRINT		Print key	
		SINGLE		Single: Auto Output to use	
		TEST		Test: Display Test	
		PRD.SEL		Product select	
		REM.KEY		Remote Key: Function to trigger	
		BLANK		Blank: Blanking function	
		THUMB		Thumb: Inputs connected to thumbwheel	
		START		Start: Start batch	
		PAUSE		Pause: Pause batch	
		ABORT		Abort: Abort batch	
		PSE.ABT		Pause/Abort: Short press to pause, long to abort.	
		ST.PS.AB		Start/Pause/Abort. Short press to toggle between start and pause, long to abort.	
SUSPND		Suspend batch			
REPORT		Print report			
NET.1	TYPE			Protocol type	
	SERIAL			Serial port	
	ADDR			Network address	
	SOURCE (K410 and K412 only)			Source for barcode protocol	
SER.AUT	NUM			Number of Serial outputs	
	TYPE			Frequency	
	SERIAL			Serial port	
	FORMAT			Format	
	SOURCE			Weight type	
	EV.AUTO			Custom format string	
PRINT	NUM			Number of printouts	
	HEADER			Header	
	FOOTER			Footer	
	PAGE	WIDTH			Page width
		HEIGHT			Page Height
		PG.END			Page End String
	SPACE	TOP			Blank lines at the top
		LEFT			Blank characters on the left
		BOTTOM			Blank lines at the bottom
	PRINT.1 -	TYPE			Printout type
FORMAT				Format	

L1	L2	L3	L4	Item
	PRINT.n	SERIAL		Serial port
		NAME		Name
		CUSTOM	REC.PRN	Custom string for record printout
			BAT.ST	Custom string for start of batch
			BAT.END	Custom string for end of batch
			FILL	Custom string for fill stage
			DUMP	Custom string for dump stage
			PULSE	Custom string for pulse stage
			WAIT	Custom string for wait stage
			ABORT	Custom string for abort stage
			SER.ST	Custom string for series of batches start
			SER.END	Custom string for series of batches end
			REP.ST	Custom string for start of report
			REP.PR	Custom string for each product in a report
	REP.MAT	Custom string for each material in a report		
	REP.END	Custom string for end of report		

SETP	NUM		Number of Setpoints
	SETP1 .. SETP8	TYPE	Type of setpoint
		OUTPUT	Output to use
		LOGIC	Active High or Active Low logic control
		ALARM	Setpoint Alarm
		SOURCE	Weight type
		SCOPE	Product or global targets
		HYS	Hysteresis
		MASK	Logic setpoint mask
		DELAY	Pulse delay
		ON	Pulse duration
		TIMING	Setpoint output timing
		RESET	IO to reset setpoint
		PLS.NUM	No. of output pulses when setpoint is triggered
		RST.LGC	Reset input is active when HIGH or LOW
		DLY.ON	Logic setpoint delay on
HLD.OFF	Logic setpoint hold off		
	NAME	Name of the setpoint	
BATCH	APP (K411 and K412 only)		Predefined Applications
	GEN		General
		ST.ILOCK	Start Interlock Input
		B.ILOCK	Batch Interlock Input
		Z.START	Zero on start
		Z.ILOCK	Zero interlock
		REC.CHK	Recipe check on Start of batch
		AUTO.ST	Auto Start - number of batches or continuous
		NUM.CL	Clear number of batches
		PROP.TP	Proportional control
		PROP.CL	Auto-clear proportion
		USE.PT	Preset Tare
		FLT.AV	In-flight average
		F.DISP	Fill Display to show end target or remaining
		JOG.TGT	Jog to Target or Low Tolerance
		ABT.ACT	Abort action relating to batch/material totals
	ERROR	Error handling	
	TOL	Out of Tolerance Action to beep or pause	

		PRT.OUT	Print Out used with batching
		DSD.USE	When to write data to DSD (if fitted)
		B.PREF (K410 and K412 only)	Batch preference for accuracy/speed
	MAT	Name 1...n	Material names
	STAGES	STAGES.1 – STAGES.n	
		TYPE :FILL	Filling stage
		S.FILL	Slow fill output
		M.FILL	Medium fill output
		F.FILL	Fast fill output
		INPUT	Input to end fill stage
		IN.WAIT	Wait for input before ending stage
		I.LOCK	Interlock input
		STG.OUT	Stage output
		FEEDER	Feeder control single/multiple
		MAT (K411 only)	Material
		ST.ACT	Action at start
		CORR	Correction
		DLY.ST	Delay start
		DLY.CHK	Hold off check
		DLY.END	Delay end
		JOG.ON*	Jog pulse on time
		JOG.OFF*	Jog pulse off time
		JOG.SET*	Number of jogs in a set
		MAX.SET*	Maximum number of jog sets
		DIRN	Fill direction
		TYPE :PULSE	Pulse stage
		NAME	Name of pulse stage
		PLS.OUT	Pulse output
		STG.OUT	Stage output
		INPUT	Pulse input
		TIMER	Use timer or input
		PROMPT	Prompt to be displayed
		ST.ACT	Action at start
		DLY.ST	Delay start
		DLY.END	Delay end
		LINK	Link to previous or next fill or dump stage
		TYPE :DUMP	Dump stage
		DMP.OUT	Dump output
		STG.OUT	Stage output
		ON.TOL	Check for in/out of tolerance
		I.LOCK	Interlock input
		ENABLE	Dump enable input
		EN.LTCH	Latch dump enable input
		DMP.TYP	Dump to weight or time
		CORR	Correction
		DLY.ST	Delay start
		DLY.CHK	Hold off check
		DLY.END	Delay end
		JOG.ON*	Jog pulse on time
		JOG.OFF*	Jog pulse off time
		JOG.SET*	Number of jogs in a set
		TOL.HI**	Dump target weight

			PLS.TIME***	Pulse time to dump
ANL.OUT	ABS			Use absolute weight
	SOURCE			Weight type
	RANGE			Weight range
	WGT.LO			Weight for low transmission
	WGT.HI			Weight for high transmission
End	End			Save and Close

18. Appendix 5: Error Messages

18.1. Overview

A number of error messages may be displayed to warn of operation outside of the acceptable limits. These messages may appear on either the primary or the secondary display. Short messages (XXXXXX) will appear as a single message. Longer messages (XXXXXX) (YYYYYY) will appear on the display in two parts, first the (XXXXXX) part, then the (YYYYYY) part.

18.2. Weighing Errors

These messages show status messages or errors that may occur during normal weighing operation.

Error	Description	Resolution
(U.LOAD)	The weight is below the minimum allowable weight reading.	Increase the weight or decrease the minimum allowable weight reading.
(O.LOAD)	The weight is above the maximum allowable weight reading. Warning - overloading may damage mechanical scale elements.	Check the condition of load cell connections. Check for damaged load cell.
(ERROR) (RANGE)	The weight reading is beyond the limit set for Zero operation. The operation of the <ZERO> key is limited in the setup during installation. The indicator cannot be Zeroed at this weight.	Increase the Zero Range (Z.RANGE) or use the <TARE> key instead.
(ERROR) (MOTION)	Scale motion has prevented a <ZERO> or <TARE> operation from occurring on command.	Try the operation again once the scale is stable.
(ERROR) (ADC)	An error with the ADC has prevented a <ZERO> or <TARE> operation from occurring	Ensure load cell cabling is correct.

18.3. Setup Errors

These messages show status messages or errors that may occur during the instrument setup.

Error	Description	Resolution
(ENTRY) (DENIED)	When accessing setup, more than three attempts have been made with the incorrect passcode.	Turn the instrument off. When the instrument is turned back on, enter the correct passcode to access setup.
(WR DENIED) (RD DENIED)	The instrument may be in Safe Setup and an item that needs Full Setup has been selected for editing.	Access Full Setup to access this item.

18.4. Diagnostic Errors

The instrument continually monitors the condition of the internal circuits. Any faults or out-of-tolerance conditions are shown on the display as an **E** type error message.

In the table below the following terms are used:

- **Check:** This item can be checked on site by service personnel.
- **Return for Service:** The instrument must be returned for factory service.

Error	Description	Resolution
(E0001)	The power supply voltage is too low.	Check supply
(E0002)	The power supply voltage is too high.	Check scale / cables
(E0004)	Positive sense voltage out of range.	Check scale connections and SCALE:BUILD:CABLE setting.
(E0008)	Negative sense voltage out of range.	Check scale connections and SCALE:BUILD:CABLE setting.
(E0010)	Temperature is outside of allowable limits	Check location
(E0020)	Module Error	Replace Module
(E0080)	Zero Interlock failed	Check scale/settings, restart batch
(E0200)	The calibration information has been lost.	Re-calibrate
(E0400)	The factory information has been lost.	Return for Service
(E0800)	Application settings have been set to defaults.	Check and re-enter application settings
(E1000)	ADC error (ADC step failed)	Check scale/settings, restart batch
(E2000)	ADC Out of Range Error. This may be caused from a broken load cell cable.	Check BUILD:CABLE setting. Check load cell cable, wiring, etc.
(E4000)	The runtime information has been lost.	Check Zero and tare settings.

The **E** type error messages are additive. For example, if instrument is running off batteries and the temperature drops, the battery voltage may be too low. The resulting error messages will be **E 0011** (0001 + 0010). The numbers add in hexadecimal as follows:

1 - 2 - 3 - 4 - 5 - 6 - 7 - 8 - 9 - A - B - C - D - E - F
 (For example, 2 + 4 = 6, or 4 + 8 = C)

18.4.1. Calibration Errors

Following are a list of the possible error messages that may be displayed to warn of failed or incorrect calibration:

Error	Description	Resolution
(FAILED) (BAND)	An attempt has been made to calibrate with a weight or signal which is not in the valid range.	Check weights and retry.
(FAILED) (ERROR)	An attempt has been made to calibrate while the scale signal is not valid.	Check load cell connection and the 4-wire/6-wire setting.
(FAILED) (TIMEOUT)	For an unknown reason, the calibration was unable to complete.	Retry.
(FAILED) (RES)	An attempt has been made to calibrate the scale to a resolution which is too high for the instrument.	Check weights and retry.
(FAILED) (TOO CLOSE)	An attempt has been made to add a linearisation point too close to zero, span or another linearisation point.	Check weights and retry.

18.5. Pause Conditions

The following table lists the possible pause messages that may be displayed due to the condition noted.

Pause Display	Description	Resolution
"OPER"	Operator pause via function key	Press Start when ready
"OLOAD", "ULOAD"	Paused due to an overload or underload error having occurred.	Take action as required for error then Start to restart batching.
"ERROR"	System error present or ADC operation failed for some reason. The error will be shown on the lower right display.	Take action as required to resolve the error. Press Start to restart batching.
"TOL"	Paused because out of tolerance on Fill stage. This only occurs if the option (Pause on out of tolerance) is enabled.	Take action as required. Press Start to restart batching.
"ILOCK"	Paused because interlock condition not met (start, fill, dump interlocks)	Activate interlock condition. Press Start to restart batching.
"INFLIGHT"	Pause if fast, medium, and slow fills are not set to switch in the correct order, or the in-flight is greater than the fill target.	Using the inflight key, check F.PRE (if used), M.PRE (if used) and FLIGHT. Compare in-flight to fill target. Press Start to restart batching.
"SUSPEND"	Operator suspend via function key	Press Start when ready

19. Glossary

19.1. Glossary Terms

Term	Definition
Count-by	The smallest change in weight units that the display can show. See also Resolution.
Division	A single graduation.
EEPROM	Electrically Erasable Programmable Read-Only Memory
EMC	Electro-Magnetic Compatibility Regulation
FIR	Finite Impulse Response
Full Scale	The maximum gross weight allowed on the scale. This is used to detect overload and underload conditions, etc.
Graduations	The maximum number of display steps between zero gross load and full capacity gross load. It is equal to the full scale divided by the resolution.
LED	Light Emitting Diode
NTEP	National Type Evaluation Program
OIML	International Organization of Legal Metrology
PLC	Programmable Logic Controller
Range	Total change in weight between zero gross load and full capacity gross load (i.e. the nominated total capacity of the scale). It is always given in displayed weight units.
Resolution	The smallest change in weight units that the display can show. See also Count-by.
RFI	Radio Frequency Interference
Optical Communications Cable	Opto-isolated infrared communications cable which uses a magnetically coupled head to attach to the front of the instrument
RS-232	Standard for communications hardware layers.
Step-Response	The step-response is the time between placing a weight on the scale and the correct weight reading being displayed.
Transients	A temporary voltage oscillation or spike caused by a sudden change of load (or other external influence).
Units	The actual units of measurement (kilograms, tonnes, pounds, etc.).

19.2. List of Figures

Figure 1: Weight Indicator	6
Figure 2: Cable Connections	10
Figure 3: 4-Wire Connections	11
Figure 4: Load cell Connections	11
Figure 5: RS-232 - Instrument to PC using COM Port (DB9).....	12
Figure 6: RS-232 – Instrument to Printer (DB25).....	12
Figure 7: RS-232 Short Cable Runs (Ring Network using COM Port).....	13
Figure 8: RS-232 Long Cable Runs (Ring Network using COM Port)	14
Figure 9: Optical Communications attachment	15
Figure 10: Cable Shield Connection	16
Figure 11 - Instrument Module View	18
Figure 12: Chart - Zero and Span Points to Interpolate Weight from Load Cell	47
Figure 13: Chart - Non-Linear Characteristic for Load Cell Output.....	49
Figure 14: OVER vs. UNDER setpoints.....	67
Figure 15: Trade label position.	119
Figure 16: Lead seal on rear of instrument.	120
Figure 17: Lead seal on boot.	120
Figure 18: Destructible sticker seal on rear of instrument.....	121
Figure 19: Destructible sticker seal on boot.....	121

19.3. List of Tables

Table 1: Industrial vs Trade Modes.....	45
Table 2: Network error codes.....	53
Table 3 - Auto Weight Format Strings.....	58
Table 4 - Auto Weight String Descriptors.....	59
Table 5: Instrument Status for Logic Setpoints	70
Table 6: Setpoint Status for Logic Setpoints.....	71
Table 7: ASCII Table.....	122
Table 8: Print tokens: generic	123
Table 9: Print tokens: pages	123
Table 10: Print tokens: weight information.....	124
Table 11: Print tokens: Product and Grand Total Information.....	126
Table 12: Print tokens: formatting	126

20. Index

- 4**
4-Wire Connection, 11
- 6**
6-Wire Connection, 11
- A**
Automatic Weight Output, 59
Auxiliary Connection, 12
- B**
Batching
 Applications, 75, 109
 General Setup, 81, 110
 Special Functions, 27, 80
- C**
Cable Connections, 10
Calibration, 47
Calibration Counter, 47
Clear Linearisation, 51
CLR.LIN, 51
Connecting Shields, 17
- D**
Data Entry, 42
 Numeric Entry, 43
 Selections and Options, 43
DC Power Supply, 10
- Diagnostic Errors, 142
Digital Calibration with Test Weights, 47
Direct mV/V Calibration, 49
Direct Span Calibration, 49
Direct Zero Calibration, 49
Document Conventions, 7
DUMP Stage, 77, 115
- E**
Earthing, 18
ED.LIN, 51
Edit Linearisation Points, 51
Electrical Safety, 9
EMC Immunity, 9
Error Messages, 141
Exiting Full or Safe Setup, 41
- F**
FILL Stage, 76, 82, 113
Filtering Techniques, 46
FLIGHT, 32, 79, 85, 88
Full Setup Passcode, 41
FUNCTION Key, 26
- G**
General Setup Information, 40
- Glossary of Terms, 145
Groups and Items, 87
- I**
Industrial vs OIML and NTEP Mode, 46
- L**
Load Cell Connection, 10
Load Cell Signals, 10
- N**
NVRAM, 6
- O**
Operator Manual, 7
Optical Communications, 16
- P**
Passcode, 40
Power – On/Off, 23
Power Key Locked, 23
Printing, 62, 82, 98, 99, 102, 104, 124
PULSE Stage, 31, 75, 78, 79, 82, 116, 139
- Q**
Quick Start Manual, 7
- R**
Recipe, 25, 27, 32, 75, 110
Reference Manual, 7
RFI, 145
- RS-232 Serial, 12
- S**
Safe Setup Passcode, 41
Scale Build, 10
Sealing Requirements, 18
Serial PC Link, 12
Serial Printer Connections, 12
Serial Remote Display, 12, 14
Setpoints, 31, 67, 68, 107, 138
Setup Display Prompts, 40
Setup Errors, 141
Setup Menu Quick Reference, 136
Span Calibration Routine, 49
Specifications, 7, 8
Stability Considerations, 23
- T**
TARE Key, 24
TEST, 27
- U**
Using Linearisation, 50
- W**
Weighing Errors, 141
- Z**
Zero Calibration Routine, 48
ZERO Key, 24

Notes

Notes